



International Journal of Computer Science & Emerging Technologies

ISSN 2044-6004 (Online)

Volume 2 Issue 3

June, 2011

© ExcelingTech Publisher 2011

<http://ojs.excelingtech.co.uk/index.php/IJCSET>

ijcset@gmail.com

IJCSET BOARD MEMBERS

Editor in Chief

I.Khan, UK

N. Aslam, UK

Editorial Members

- **Sattar B. Sadkhan**, USA
- **Khoa N. Le**, Australia
- **Sasan Adibi**, Canada
- **Mostafa M. El-Said**, USA
- **Nidaa A. Abbas**, IRAQ
- **Eleonora Pantano**, Italy
- **Yin-Fu Huang**, Taiwan
- **TAIB Nabil**, ALGERIA
- **Dilip S. Aldar**, India
- **John Woods**, UK
- **Ing. Reuben Farrugia**, Malta
- **Pankaj Kumar**, India
- **T.V. Narayana Rao**, India
- **N. RADHIKA**, India
- **N. Srividya**, India
- **Osman Ismail**, Saudi Arabia
- **Sultan Aljahdali**, Saudi Arabia
- **Mohammed Badawy**, Egypt
- **Munir Ahmed**, Saudi Arabia
- **M. ABDUL RAHMAN**, India
- **Raiz ul islam**, South Korea

- **Nafiz Imtiaz Bin Hamid**, Bangladesh
- **Jasvir Singh**, India
- **Manas Ranjan Biswal**, India
- **Ratnadeep R. Deshmukh**, India
- **Sujni Paul**, India
- **Mousa Demba**, Saudi Arabia
- **Yasser Alginahi**, Saudi Arabia
- **Tarun Kumar**, India
- **Alessandro Agostini**, Saudi Arabia

TABLE OF CONTENTS

1. \ddot{g} -CLOSED SETS IN TOPOLOGY.....	330
O. Ravi, S. Ganesan	
2. DECOMPOSITION OF CONTINUITY USING $g^{\#}$-CLOSED SETS.....	338
O. Ravi, S. Ganesan, R. Latha	
3. DANCE - DATA ACCORDANCE BY NODAL CLOUD EMISSION.....	341
SarathChand P.V, Dr.Balraju M, Benarji T, Vishvapathi P.	
4. MATHEMATICAL ANALYSIS OF DATA MINING IN HIGHER EDUCATION	345
M.P.Chaudhary, Kriti Gupta, Alpana Jijja, Rajan Vohra	
5. GROWING HIERARCHICAL ADAPTIVE SELF-ORGANIZING MAP FOR PHONEME CLASSIFICATION.....	354
Chiraz Jlassi, Najet Arous, Nouredine Ellouze	
6. ASSESSMENT OF MOBILE AGENT FRAMEWORKS BASED ON SECURITY.....	364
Dr.Shuchita Upadhyaya, Pooja	
7. POLICY LEVELS CONCERNING DATABASE SECURITY.....	368
Khaleel Ahmad, Jayant Shekhar, Nitesh Kumar, K.P. Yadav	
8. BIOLOGICAL SEQUENCE MATCHING USING BOOLEAN ALGEBRA.....	373
Nivit Gill, Shailendra Singh	
9. TOTAL POWER-SPEED OPTIMIZATION USING MULTI-THRESHOLD VOLTAGE (MVT) LIBRARY AND VT SWAPPING FLOW	378
Miloni Ganatra, Niraj Jani, Jigneshpanwala	
10. ROLE OF GEOGRAPHICAL INFORMATION SYSTEMS ON INTERSECTING FUNCTIONALITIES OF BANKING AND INSURANCE SECTORS.....	383
Kalli Srinivasa Nageswara Prasad, Prof. S.Ramakrishna	

11. A NEW SCHEME FOR DETECTING CMFS AND EXCLUDING FAULTY SENSOR NODES FROM THE NETWORK	389
Hamideh Jafarian, Shahram Babaie, Ali Hosseinalipour	
12. RECONFIGURING HIGH SPEED NETWORKS	393
Naresh Kumar, Renu Vig, Deepak Bagai	
13. COMPARISON THREE RESOURCE DISCOVERY ALGORITHMS IN GRID COMPUTING	402
Leyli Mohammad Khanlil, Parisa Falahati, Shahram Babaie	
14. DEVELOPMENT STRATEGIES FOR E-LMSS	406
Vibha Ojha, Neha Sharma, Anand Sharma, Sandesh Jain	
15. MODEL ORDER REDUCTION USING BIO-INSPIRED PSO AND BFO SOFT - COMPUTING FOR COMPARATIVE STUDY	410
Sudhir Y Kumar, PK.Ghosh, S Mukherjee	
16. THE EVALUATION OF EFFICIENT IP TRACE BACK WITH SPECIFIED PROBABILITY BY INATTENTIVE NETWORK MODEL.....	418
Babu.S, Kranthi Kumar.G, V N V Phani Kumar .V	
17. LMI CONDITION FOR SYNCHRONIZATION OF NEURAL NETWORK WITH PARAMETER.....	425
Lu Dianchen, Qi Qiaoxia	
18. AN OPTICAL NEURAL NETWORK TECHNIQUE FOR MINING FREQUENT MAXIMAL ITEMSETS IN LARGE DATABASES	431
Divya Bhatnagar, A. S. Saxena	
19. LOCALIZE INDIVIDUALS IN SPACES OF INTERACTION - ANALYSIS OF ONLINE REVIEW PROCESSES FOR GIS	435
Gilbert Ahamer	

\ddot{g} -Closed Sets in Topology

¹O. Ravi and ²S. Ganesan

¹Department of Mathematics, P. M. Thevar College, Usilampatti, Madurai District, Tamil Nadu, India.

E-mail: siingam@yahoo.com

²Department of Mathematics, N. M. S. S. V. N College, Nagamalai, Madurai, Tamil Nadu, India.

E-mail: sgsgsgsgsg77@yahoo.com

Abstract -- In this paper, we offer a new class of sets called \ddot{g} -closed sets in topological spaces and we study some of its basic properties. It turns out that this class lies between the class of closed sets and the class of g-closed sets.

Key words and Phrases: Topological space, g-closed set,

\ddot{g} -closed set, \ddot{g} -open set, ω -closed set.

1. Introduction

In 1963 Levine [19] introduced the notion of semi-open sets. According to Cameron [8] this notion was Levine's most important contribution to the field of topology. The motivation behind the introduction of semi-open sets was a problem of Kelley which Levine has considered in [20], i.e., to show that $\text{cl}(U) = \text{cl}(U \cap D)$ for all open sets U and dense sets D . He proved that U is semi-open if and only if $\text{cl}(U) = \text{cl}(U \cap D)$ for all dense sets D and D is dense if and only if $\text{cl}(U) = \text{cl}(U \cap D)$ for all semi-open sets U . Since the advent of the notion of semi-open sets, many mathematicians worked on such sets and also introduced some other notions, among others, preopen sets [22], α -open sets [24] and β -open sets [1] (Andrijevic [3] called them semi-pre open sets). It has been shown [12] recently that the notion of preopen sets and semi-open sets are important with respect to the digital plane.

Levine [18] also introduced the notion of g-closed sets and investigated its fundamental properties. This notion was shown to be productive and very useful. For example it is shown that g-closed sets can be used to characterize the extremally disconnected spaces and the submaximal spaces (see [9] and [10]). Moreover the study of g-closed sets led to some separation axioms between T_0 and T_1 which proved to be useful in computer science and digital topology (see [17] and [14]).

Recently, Bhattacharya and Lahiri [5], Arya and Nour [4], Sheik John [29] and Rajamani and Viswanathan [26] introduced sg-closed sets, gs-

closed sets, ω -closed sets and $\alpha g s$ -closed sets respectively.

In this paper, we introduce a new class of sets namely \ddot{g} -closed sets in topological spaces. This class lies between the class of closed sets and the class of g-closed sets. This class also lies between the class of closed sets and the class of ω -closed sets.

2. Preliminaries

Throughout this paper (X, τ) and (Y, σ) (or X and Y) represent topological spaces on which no separation axioms are assumed unless otherwise mentioned. For a subset A of a space (X, τ) , $\text{cl}(A)$, $\text{int}(A)$ and A^c denote the closure of A , the interior of A and the complement of A respectively.

We recall the following definitions which are useful in the sequel.

2.1. Definition

A subset A of a space (X, τ) is called:

- (i) semi-open set [19] if $A \subseteq \text{cl}(\text{int}(A))$;
- (ii) preopen set [22] if $A \subseteq \text{int}(\text{cl}(A))$;
- (iii) α -open set [24] if $A \subseteq \text{int}(\text{cl}(\text{int}(A)))$;
- (iv) β -open set [1] (= semi-preopen [3]) if $A \subseteq \text{cl}(\text{int}(\text{cl}(A)))$;
- (v) Regular open set [30] if $A = \text{int}(\text{cl}(A))$.

The complements of the above mentioned open sets are called their respective closed sets.

The preclosure [25] (resp. semi-closure [11], α -closure [24], semi-pre-closure [3]) of a subset A of X , denoted by $\text{pcl}(A)$ (resp. $\text{scl}(A)$, $\alpha \text{cl}(A)$, $\text{spcl}(A)$) is defined to be the intersection of all preclosed (resp. semi-closed, α -closed, semi-preclosed) sets of (X, τ) containing A . It is known that $\text{pcl}(A)$ (resp. $\text{scl}(A)$, $\alpha \text{cl}(A)$, $\text{spcl}(A)$) is a preclosed (resp. semi-closed, α -closed, semi-preclosed) set. For any subset A of an arbitrarily chosen topological space, the semi-interior [11] (resp.

α -interior [24], preinterior [25]) of A, denoted by $\text{sint}(A)$ (resp. $\alpha \text{int}(A)$, $\text{pint}(A)$), is defined to be the union of all semi-open (resp. α -open, preopen) sets of (X, τ) contained in A.

2.2. Definition

A subset A of a space (X, τ) is called:

- (i) a generalized closed (briefly g-closed) set [18] if $\text{cl}(A) \subseteq U$ whenever $A \subseteq U$ and U is open in (X, τ) . The complement of g-closed set is called g-open set;
- (ii) a semi-generalized closed (briefly sg-closed) set [5] if $\text{scl}(A) \subseteq U$ whenever $A \subseteq U$ and U is semi-open in (X, τ) . The complement of sg-closed set is called sg-open set;
- (iii) a generalized semi-closed (briefly gs-closed) set [4] if $\text{scl}(A) \subseteq U$ whenever $A \subseteq U$ and U is open in (X, τ) . The complement of gs-closed set is called gs-open set;
- (iv) an α -generalized closed (briefly α g-closed) set [21] if $\alpha \text{cl}(A) \subseteq U$ whenever $A \subseteq U$ and U is open in (X, τ) . The complement of α g-closed set is called α g-open set;
- (v) a generalized semi-preclosed (briefly gsp-closed) set [25] if $\text{spcl}(A) \subseteq U$ whenever $A \subseteq U$ and U is open in (X, τ) . The complement of gsp-closed set is called gsp-open set;
- (vi) a \hat{g} -closed set [31] (ω -closed [29]) if $\text{cl}(A) \subseteq U$ whenever $A \subseteq U$ and U is semi-open in (X, τ) . The complement of \hat{g} -closed set is called \hat{g} -open set;
- (vii) a αgs -closed set [26] if $\alpha \text{cl}(A) \subseteq U$ whenever $A \subseteq U$ and U is semi-open in (X, τ) . The complement of αgs -closed set is called αgs -open set;
- (viii) Ψ -closed set [23, 32] if $\text{scl}(A) \subseteq U$ whenever $A \subseteq U$ and U is sg-open in (X, τ) . The complement of Ψ -closed set is called Ψ -open set;
- (ix) a \ddot{g}_α -closed set [27] if $\alpha \text{cl}(A) \subseteq U$ whenever $A \subseteq U$ and U is sg-open in (X, τ) . The complement of \ddot{g}_α -closed set is called \ddot{g}_α -open set.

2.3. Remark

The collection of all \ddot{g} -closed (resp. \ddot{g}_α -closed, ω -closed, g-closed, gs-closed, gsp-closed, α g-closed, αgs -closed, sg-closed, Ψ -closed, α -closed, semi-closed) sets is denoted by $\ddot{G}_C(X)$

(resp. $\ddot{G}_\alpha C(X)$, $\omega C(X)$, $G C(X)$, $GS C(X)$, $GSP C(X)$, $\alpha g C(X)$, $\alpha GS C(X)$, $SG C(X)$, $\Psi C(X)$, $\alpha C(X)$, $S C(X)$).

The collection of all \ddot{g} -open (resp. \ddot{g}_α -open, ω -open, g-open, gs-open, gsp-open, α g-open, αgs -open, sg-open, Ψ -open, α -open, semi-open) sets is denoted by $\ddot{G}_O(X)$ (resp. $\ddot{G}_\alpha O(X)$, $\omega O(X)$, $G O(X)$, $GS O(X)$, $GSP O(X)$, $\alpha g O(X)$, $\alpha GS O(X)$, $SG O(X)$, $\Psi O(X)$, $\alpha O(X)$, $S O(X)$).

We denote the power set of X by P(X).

2.4. Definition [17]

A subset S of X is said to be locally closed if $S = U \cap F$, where U is open and F is closed in (X, τ) .

2.5. Result

- (i) Every open set is Ψ -open [23].
- (ii) Every semi-open set is Ψ -open [23].
- (iii) Every Ψ -open set is sg-open [23].
- (iv) Every semi-closed set is sg-closed [7].

3. \ddot{g} -Closed Sets

We introduce the following definition.

3.1. Definition

A subset A of X is called a \ddot{g} -closed set if $\text{cl}(A) \subseteq U$ whenever $A \subseteq U$ and U is sg-open in (X, τ) .

3.2. Proposition

Every closed set is \ddot{g} -closed.

Proof

If A is any closed set in (X, τ) and G is any sg-open set containing A, then $G \supseteq A = \text{cl}(A)$. Hence A is \ddot{g} -closed.

The converse of Proposition 3.2 need not be true as seen from the following example.

3.3. Example

Let $X = \{a, b, c\}$ with $\tau = \{\phi, \{a, b\}, X\}$.
 Then $\ddot{G}C(X) = \{\phi, \{c\}, \{a, c\}, \{b, c\}, X\}$. Here, $A = \{a, c\}$ is \ddot{g} -closed set but not closed.

3.4. Proposition

Every \ddot{g} -closed set is \ddot{g}_α -closed.

Proof

If A is a \ddot{g} -closed subset of (X, τ) and G is any sg-open set containing A , then $G \supseteq \text{cl}(A) \supseteq \alpha \text{cl}(A)$. Hence A is \ddot{g}_α -closed in (X, τ) .

The converse of Proposition 3.4 need not be true as seen from the following example.

3.5. Example

Let $X = \{a, b, c\}$ with $\tau = \{\phi, \{b\}, X\}$. Then $\ddot{G}C(X) = \{\phi, \{a, c\}, X\}$ and $\ddot{G}_\alpha C(X) = \{\phi, \{a\}, \{c\}, \{a, c\}, X\}$. Here, $A = \{a\}$ is \ddot{g}_α -closed but not \ddot{g} -closed set in (X, τ) .

3.6. Proposition

Every \ddot{g} -closed set is Ψ -closed.

Proof

If A is a \ddot{g} -closed subset of (X, τ) and G is any sg-open set containing A , then $G \supseteq \text{cl}(A) \supseteq \text{scl}(A)$. Hence A is Ψ -closed in (X, τ) .

The converse of Proposition 3.6 need not be true as seen from the following example.

3.7. Example

Let $X = \{a, b, c\}$ with $\tau = \{\phi, \{a\}, X\}$. Then $\ddot{G}C(X) = \{\phi, \{b, c\}, X\}$ and $\Psi C(X) = \{\phi, \{b\}, \{c\}, \{b, c\}, X\}$. Here, $A = \{b\}$ is Ψ -closed but not \ddot{g} -closed set in (X, τ) .

3.8. Proposition

Every \ddot{g} -closed set is ω -closed.

Proof

Suppose that $A \subseteq G$ and G is semi-open in (X, τ) . Since every semi-open set is sg-open and A is

\ddot{g} -closed, therefore $\text{cl}(A) \subseteq G$. Hence A is ω -closed in (X, τ) .

The converse of Proposition 3.8 need not be true as seen from the following example.

3.9. Example

Let $X = \{a, b, c, d\}$ with $\tau = \{\phi, \{d\}, \{b, c\}, \{b, c, d\}, X\}$. Then $\ddot{G}C(X) = \{\phi, \{a\}, \{a, d\}, \{a, b, c\}, X\}$ and $\omega C(X) = \{\phi, \{a\}, \{a, b\}, \{a, c\}, \{a, d\}, \{a, b, c\}, \{a, b, d\}, \{a, c, d\}, X\}$. Here, $A = \{a, c, d\}$ is ω -closed but not \ddot{g} -closed set in (X, τ) .

3.10. Proposition

Every Ψ -closed set is sg-closed.

Proof

Suppose that $A \subseteq G$ and G is semi-open in (X, τ) . Since every semi-open set is sg-open and A is Ψ -closed, therefore $\text{scl}(A) \subseteq G$. Hence A is sg-closed in (X, τ) .

The converse of Proposition 3.10 need not be true as seen from the following example.

3.11. Example

Let $X = \{a, b, c\}$ with $\tau = \{\phi, \{a\}, \{b, c\}, X\}$. Then $\Psi C(X) = \{\phi, \{a\}, \{b, c\}, X\}$ and $SGC(X) = P(X)$. Here, $A = \{a, b\}$ is sg-closed but not Ψ -closed set in (X, τ) .

3.12. Proposition

Every ω -closed set is α_{GS} -closed.

Proof

If A is a ω -closed subset of (X, τ) and G is any semi-open set containing A , then $G \supseteq \text{cl}(A) \supseteq \alpha \text{cl}(A)$. Hence A is α_{GS} -closed in (X, τ) .

The converse of Proposition 3.12 need not be true as seen from the following example.

3.13. Example

Let $X = \{a, b, c\}$ with $\tau = \{\phi, \{a\}, X\}$. Then $\omega C(X) = \{\phi, \{b, c\}, X\}$ and $\alpha_{GS}C(X) = \{\phi, \{b\}, \{c\}, \{b, c\}, X\}$. Here, $A = \{b\}$ is α_{GS} -closed but not ω -closed set in (X, τ) .

3.14. Proposition

Every \ddot{g} -closed set is g-closed.

Proof

If A is a \ddot{g} -closed subset of (X, τ) and G is any open set containing A , since every open set is sg -open, we have $G \supseteq cl(A)$. Hence A is g -closed in (X, τ) .

The converse of Proposition 3.14 need not be true as seen from the following example.

3.15. Example

Let $X = \{a, b, c\}$ with $\tau = \{\emptyset, \{a\}, \{b, c\}, X\}$. Then $\ddot{G}C(X) = \{\emptyset, \{a\}, \{b, c\}, X\}$ and $G C(X) = P(X)$. Here, $A = \{a, b\}$ is g -closed but not \ddot{g} -closed set in (X, τ) .

3.16. Proposition

Every \ddot{g} -closed set is αg^S -closed.

Proof

If A is a \ddot{g} -closed subset of (X, τ) and G is any semi-open set containing A , since every semi-open set is sg -open, we have $G \supseteq cl(A) \supseteq \alpha cl(A)$. Hence A is αg^S -closed in (X, τ) .

The converse of Proposition 3.16 need not be true as seen from the following example.

3.17. Example

Let $X = \{a, b, c\}$ with $\tau = \{\emptyset, \{a\}, \{b, c\}, X\}$. Then $\ddot{G}C(X) = \{\emptyset, \{a\}, \{b, c\}, X\}$ and $\alpha g^S C(X) = P(X)$. Here, $A = \{a, c\}$ is αg^S -closed but not \ddot{g} -closed set in (X, τ) .

3.18. Proposition

Every \ddot{g} -closed set is αg -closed.

Proof

If A is a \ddot{g} -closed subset of (X, τ) and G is any open set containing A , since every open set is sg -open, we have $G \supseteq cl(A) \supseteq \alpha cl(A)$. Hence A is αg -closed in (X, τ) .

The converse of Proposition 3.18 need not be true as seen from the following example.

3.19. Example

Let $X = \{a, b, c\}$ with $\tau = \{\emptyset, \{c\}, \{a, b\}, X\}$. Then $\ddot{G}C(X) = \{\emptyset, \{c\}, \{a, b\}, X\}$ and $\alpha g C(X) = P(X)$. Here, $A = \{a, c\}$ is αg -closed but not \ddot{g} -closed set in (X, τ) .

3.20. Proposition

Every \ddot{g} -closed set is gs -closed.

Proof

If A is a \ddot{g} -closed subset of (X, τ) and G is any open set containing A , since every open set is sg -open, we have $G \supseteq cl(A) \supseteq scl(A)$. Hence A is gs -closed in (X, τ) .

The converse of Proposition 3.20 need not be true as seen from the following example.

3.21. Example

Let $X = \{a, b, c\}$ with $\tau = \{\emptyset, \{a\}, X\}$. Then $\ddot{G}C(X) = \{\emptyset, \{b, c\}, X\}$ and $G^S C(X) = \{\emptyset, \{b\}, \{c\}, \{a, b\}, \{a, c\}, \{b, c\}, X\}$. Here, $A = \{c\}$ is gs -closed but not \ddot{g} -closed set in (X, τ) .

3.22. Proposition

Every \ddot{g} -closed set is gsp -closed.

Proof

If A is a \ddot{g} -closed subset of (X, τ) and G is any open set containing A , every open set is sg -open, we have $G \supseteq cl(A) \supseteq spcl(A)$. Hence A is gsp -closed in (X, τ) .

The converse of Proposition 3.22 need not be true as seen from the following example.

3.23. Example

Let $X = \{a, b, c\}$ with $\tau = \{\emptyset, \{b\}, X\}$. Then $\ddot{G}C(X) = \{\emptyset, \{a, c\}, X\}$ and $G^{SP} C(X) = \{\emptyset, \{a\}, \{c\}, \{a, b\}, \{a, c\}, \{b, c\}, X\}$. Here, $A = \{c\}$ is gsp -closed but not \ddot{g} -closed set in (X, τ) .

3.24. Remark

The following example shows that \ddot{g} -closed sets are independent of α -closed sets and semi-closed sets.

3.25. Example

Let $X = \{a, b, c\}$ with $\tau = \{\emptyset, \{a, b\}, X\}$. Then $\ddot{G}C(X) = \{\emptyset, \{c\}, \{a, c\}, \{b, c\}, X\}$ and $\alpha C(X) = S C(X) = \{\emptyset, \{c\}, X\}$. Here, $A = \{a, c\}$ is

\ddot{g} -closed but it is neither α -closed nor semi-closed in (X, τ) .

3.26. Example

Let $X = \{a, b, c\}$ with $\tau = \{\emptyset, \{a\}, X\}$. Then $\ddot{G}C(X) = \{\emptyset, \{b, c\}, X\}$ and $\alpha C(X) = S C(X) = \{\emptyset, \{b\}, \{c\}, \{b, c\}, X\}$. Here, $A = \{b\}$ is α -closed as well as semi-closed in (X, τ) but it is not \ddot{g} -closed in (X, τ) .

3.27. Remark

From the above discussions and known results in [7, 25, 26, 29, 31], we obtain the following diagram, where $A \rightarrow B$ (resp. $A \leftarrow B$) represents A implies B but not conversely (resp. A and B are independent of each other).

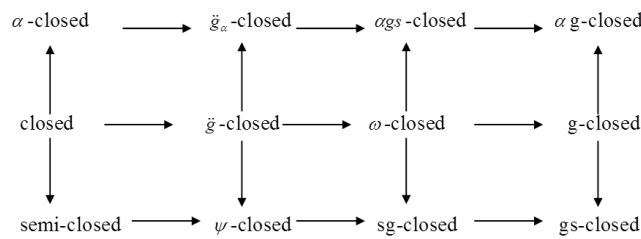

None of the above implications is reversible as shown in the remaining examples and in the related papers [7, 25, 26, 29, 31].

4. Properties of \ddot{g} -Closed Sets

In this section, we have proved that an arbitrary intersection of \ddot{g} -closed sets is \ddot{g} -closed. Moreover, we discuss some basic properties of \ddot{g} -closed sets.

4.1. Definition

The intersection of all sg-open subsets of (X, τ) containing A is called the sg-kernel of A and denoted by $\text{sg-ker}(A)$.

4.2. Lemma

A subset A of (X, τ) is \ddot{g} -closed if and only if $\text{cl}(A) \subseteq \text{sg-ker}(A)$.

Proof

Suppose that A is \ddot{g} -closed. Then $\text{cl}(A) \subseteq U$ whenever $A \subseteq U$ and U is sg-open. Let $x \in \text{cl}(A)$. If $x \notin \text{sg-ker}(A)$, then there is a sg-open set U containing A such that $x \notin U$. Since U is a sg-open

set containing A , we have $x \notin \text{cl}(A)$ and this is a contradiction.

Conversely, let $\text{cl}(A) \subseteq \text{sg-ker}(A)$. If U is any sg-open set containing A , then $\text{cl}(A) \subseteq \text{sg-ker}(A) \subseteq U$. Therefore, A is \ddot{g} -closed.

4.3. Proposition

For any subset A of (X, τ) , $X_2 \cap \text{cl}(A) \subseteq \text{sg-ker}(A)$, where $X_2 = \{x \in X : \{x\} \text{ is preopen}\}$.

Proof

Let $x \in X_2 \cap \text{cl}(A)$ and suppose that $x \notin \text{sg-ker}(A)$. Then there is a sg-open set U containing A such that $x \notin U$. If $F = X - U$, then F is sg-closed. Since $\text{cl}(\{x\}) \subseteq \text{cl}(A)$, we have $\text{int}(\text{cl}(\{x\})) \subseteq A \cup \text{int}(\text{cl}(A))$. Again since $x \in X_2$, we have $x \notin X_1$ and so $\text{int}(\text{cl}(\{x\})) = \emptyset$. Therefore, there has to be some $y \in A \cap \text{int}(\text{cl}(\{x\}))$ and hence $y \in F \cap A$, a contradiction.

4.4. Theorem

A subset A of (X, τ) is \ddot{g} -closed if and only if $X_1 \cap \text{cl}(A) \subseteq A$, where $X_1 = \{x \in X : \{x\} \text{ is nowhere dense}\}$.

Proof

Suppose that A is \ddot{g} -closed. Let $x \in X_1 \cap \text{cl}(A)$. Then $x \in X_1$ and $x \in \text{cl}(A)$. Since $x \in X_1$, $\text{int}(\text{cl}(\{x\})) = \emptyset$. Therefore, $\{x\}$ is semi-closed, since $\text{int}(\text{cl}(\{x\})) \subseteq \{x\}$. Since every semi-closed set is sg-closed [Result 2.5 (4)], $\{x\}$ is sg-closed. If $x \notin A$ and if $U = X \setminus \{x\}$, then U is a sg-open set containing A and so $\text{cl}(A) \subseteq U$, a contradiction.

Conversely, suppose that $X_1 \cap \text{cl}(A) \subseteq A$. Then $X_1 \cap \text{cl}(A) \subseteq \text{sg-ker}(A)$, since $A \subseteq \text{sg-ker}(A)$. Now $\text{cl}(A) = X \cap \text{cl}(A) = (X_1 \cup X_2) \cap \text{cl}(A) = (X_1 \cap \text{cl}(A)) \cup (X_2 \cap \text{cl}(A)) \subseteq \text{sg-ker}(A)$, since $X_1 \cap \text{cl}(A) \subseteq \text{sg-ker}(A)$ and Proposition 4.3. Thus, A is \ddot{g} -closed by Lemma 4.2.

4.5. Theorem

An arbitrary intersection of \ddot{g} -closed sets is \ddot{g} -closed.

Proof

Let $F = \{A_i : i \in \wedge\}$ be a family of \ddot{g} -closed sets and let $A = \bigcap_{i \in \wedge} A_i$. Since $A \subseteq A_i$ for each i , $X \setminus \text{cl}(A) \subseteq X \setminus \text{cl}(A_i)$ for each i . Using Theorem 4.4 for each \ddot{g} -closed set A_i , we have $X \setminus \text{cl}(A_i) \subseteq A_i$. Thus, $X \setminus \text{cl}(A) \subseteq X \setminus \text{cl}(A_i) \subseteq A_i$ for each $i \in \wedge$. That is, $X \setminus \text{cl}(A) \subseteq A$ and so A is \ddot{g} -closed by Theorem 4.4.

4.6. Corollary

If A is a \ddot{g} -closed set and F is a closed set, then $A \cap F$ is a \ddot{g} -closed set.

Proof

Since F is closed, it is \ddot{g} -closed. Therefore by Theorem 4.5, $A \cap F$ is also a \ddot{g} -closed set.

4.7. Proposition

If A and B are \ddot{g} -closed sets in (X, τ) , then $A \cup B$ is \ddot{g} -closed in (X, τ) .

Proof

If $A \cup B \subseteq G$ and G is sg-open, then $A \subseteq G$ and $B \subseteq G$. Since A and B are \ddot{g} -closed, $G \supseteq \text{cl}(A)$ and $G \supseteq \text{cl}(B)$ and hence $G \supseteq \text{cl}(A) \cup \text{cl}(B) = \text{cl}(A \cup B)$. Thus $A \cup B$ is \ddot{g} -closed set in (X, τ) .

4.8. Proposition

If a set A is \ddot{g} -closed in (X, τ) , then $\text{cl}(A) - A$ contains no nonempty closed set in (X, τ) .

Proof

Suppose that A is \ddot{g} -closed. Let F be a closed subset of $\text{cl}(A) - A$. Then $A \subseteq F^c$. But A is \ddot{g} -closed, therefore $\text{cl}(A) \subseteq F^c$. Consequently, $F \subseteq (\text{cl}(A))^c$. We already have $F \subseteq \text{cl}(A)$. Thus $F \subseteq \text{cl}(A) \cap (\text{cl}(A))^c$ and F is empty.

The converse of Proposition 4.8 need not be true as seen from the following example.

4.9. Example

Let $X = \{a, b, c\}$ with $\tau = \{\emptyset, \{a\}, X\}$. Then $\ddot{G}C(X) = \{\emptyset, \{b, c\}, X\}$. If $A = \{b\}$, then $\text{cl}(A) - A = \{c\}$ does not contain any nonempty closed set. But A is not \ddot{g} -closed in (X, τ) .

4.10. Theorem

A set A is \ddot{g} -closed if and only if $\text{cl}(A) - A$ contains no nonempty sg-closed set.

Proof

Necessity. Suppose that A is \ddot{g} -closed. Let S be a sg-closed subset of $\text{cl}(A) - A$. Then $A \subseteq S^c$. Since A is \ddot{g} -closed, we have $\text{cl}(A) \subseteq S^c$. Consequently, $S \subseteq (\text{cl}(A))^c$. Hence, $S \subseteq \text{cl}(A) \cap (\text{cl}(A))^c = \emptyset$. Therefore S is empty.

Sufficiency. Suppose that $\text{cl}(A) - A$ contains no nonempty sg-closed set. Let $A \subseteq G$ and G be sg-open. If $\text{cl}(A) \not\subseteq G$, then $\text{cl}(A) \cap G^c \neq \emptyset$. Since $\text{cl}(A)$ is a closed set and G^c is a sg-closed set, $\text{cl}(A) \cap G^c$ is a nonempty sg-closed subset of $\text{cl}(A) - A$. This is a contradiction. Therefore, $\text{cl}(A) \subseteq G$ and hence A is \ddot{g} -closed.

4.11. Proposition

If A is \ddot{g} -closed in (X, τ) and $A \subseteq B \subseteq \text{cl}(A)$, then B is \ddot{g} -closed in (X, τ) .

Proof

Since $B \subseteq \text{cl}(A)$, we have $\text{cl}(B) \subseteq \text{cl}(A)$. Then, $\text{cl}(B) - B \subseteq \text{cl}(A) - A$. Since $\text{cl}(A) - A$ has no nonempty sg-closed subsets, neither does $\text{cl}(B) - B$. By Theorem 4.10, B is \ddot{g} -closed.

4.12. Proposition

Let $A \subseteq Y \subseteq X$ and suppose that A is \ddot{g} -closed in (X, τ) . Then A is \ddot{g} -closed relative to Y .

Proof

Let $A \subseteq Y \cap G$, where G is sg-open in (X, τ) . Then $A \subseteq G$ and hence $\text{cl}(A) \subseteq G$. This implies

that $Y \cap \text{cl}(A) \subseteq Y \cap G$. Thus A is \ddot{g} -closed relative to Y .

4.13. Proposition

If A is a sg-open and \ddot{g} -closed in (X, τ) , then A is closed in (X, τ) .

Proof

Since A is sg-open and \ddot{g} -closed, $\text{cl}(A) \subseteq A$ and hence A is closed in (X, τ) .

Recall that a topological space (X, τ) is called extremally disconnected if $\text{cl}(U)$ is open for each $U \in \tau$.

4.14. Theorem

Let (X, τ) be extremally disconnected and A a semi-open subset of X . Then A is \ddot{g} -closed if and only if it is sg-closed.

Proof

It follows from the fact that if (X, τ) is extremally disconnected and A is a semi-open subset of X , then $\text{scl}(A) = \text{cl}(A)$ (Lemma 0.3 [15]).

4.15. Theorem

Let A be a locally closed set of (X, τ) . Then A is closed if and only if A is \ddot{g} -closed.

Proof

(i) \Rightarrow (ii). It is fact that every closed set is \ddot{g} -closed.

(ii) \Rightarrow (i). By Proposition 5.1.3.3 of Bourbaki [6], $A \cup (X - \text{cl}(A))$ is open in (X, τ) , since A is locally closed. Now $A \cup (X - \text{cl}(A))$ is sg-open set of (X, τ) such that $A \subseteq A \cup (X - \text{cl}(A))$. Since A is \ddot{g} -closed, then $\text{cl}(A) \subseteq A \cup (X - \text{cl}(A))$. Thus, we have $\text{cl}(A) \subseteq A$ and hence A is a closed.

4.16. Proposition

For each $x \in X$, either $\{x\}$ is sg-closed or $\{x\}^c$ is \ddot{g} -closed in (X, τ) .

Proof

Suppose that $\{x\}$ is not sg-closed in (X, τ) . Then $\{x\}^c$ is not sg-open and the only sg-open set containing $\{x\}^c$ is the space X itself. Therefore $\text{cl}(\{x\}^c) \subseteq X$ and so $\{x\}^c$ is \ddot{g} -closed in (X, τ) .

4.17. Theorem

Let A be a \ddot{g} -closed set of a topological space (X, τ) . Then,

- (i) $\text{sint}(A)$ is \ddot{g} -closed.
- (ii) If A is regular open, then $\text{pint}(A)$ and $\text{scl}(A)$ are also \ddot{g} -closed sets.
- (iii) If A is regular closed, then $\text{pcl}(A)$ is also \ddot{g} -closed.

Proof

(i) Since $\text{cl}(\text{int}(A))$ is a closed set in (X, τ) , by Corollary 4.6, $\text{sint}(A) = A \cap \text{cl}(\text{int}(A))$ is \ddot{g} -closed in (X, τ) .

(ii) Since A is regular open in X , $A = \text{int}(\text{cl}(A))$. Then $\text{scl}(A) = A \cup \text{int}(\text{cl}(A)) = A$. Thus, $\text{scl}(A)$ is \ddot{g} -closed in (X, τ) . Since $\text{pint}(A) = A \cap \text{int}(\text{cl}(A)) = A$, $\text{pint}(A)$ is \ddot{g} -closed.

(iii) Since A is regular closed in X , $A = \text{cl}(\text{int}(A))$. Then $\text{pcl}(A) = A \cup \text{cl}(\text{int}(A)) = A$. Thus, $\text{pcl}(A)$ is \ddot{g} -closed in (X, τ) .

The converses of the statements in the Theorem 4.17 are not true as we see in the following examples.

4.18. Example

Let $X = \{a, b, c\}$ with $\tau = \{\emptyset, \{c\}, \{b, c\}, X\}$. Then $\ddot{G}C(X) = \{\emptyset, \{a\}, \{a, b\}, X\}$. Then the set $A = \{b\}$ is not a \ddot{g} -closed set. However $\text{sint}(A) = \emptyset$ is a \ddot{g} -closed.

4.19. Example

Let $X = \{a, b, c\}$ with $\tau = \{\emptyset, \{a\}, \{b\}, \{a, b\}, \{a, c\}, X\}$. Then $\ddot{G}C(X) = \{\emptyset, \{b\}, \{c\}, \{a, c\}, \{b, c\}, X\}$. Then the set $A = \{c\}$ is not regular open.

However A is \ddot{g} -closed and $\text{scl}(A) = \{c\}$ is a \ddot{g} -closed and $\text{pint}(A) = \emptyset$ is also \ddot{g} -closed.

4.20. Example

Let $X = \{a, b, c\}$ with $\tau = \{\emptyset, \{a, b\}, X\}$. Then $\ddot{G}C(X) = \{\emptyset, \{c\}, \{a, c\}, \{b, c\}, X\}$. Then the set $A = \{c\}$ is not regular closed. However A is a \ddot{g} -closed and $\text{pcl}(A) = \{c\}$ is \ddot{g} -closed.

References

1. Abd El-Monsef, M. E., El-Deeb, S. N. and Mahmoud, R. A.: β -open sets and β -continuous mapping, Bull. Fac. Sci. Assiut Univ, 12(1983), 77-90.
2. Aho, T. and Nieminen, T.: Spaces in which subsets are semi-open, Ricerche Mat., 43(1994), 45-59.
3. Andrijevic, D.: Semi-preopen sets, Mat. Vesnik, 38(1986), 24-32.
4. Arya, S. P. and Nour, T.: Characterization of s -normal spaces, Indian J. Pure. Appl. Math, 21(8)(1990), 717-719.
5. Bhattacharya, P. and Lahiri, B. K.: Semi-generalized closed sets in topology, Indian J. Math, 29(3)(1987), 375-382.
6. Bourbaki, N.: General topology, Part I, Addison-Wesley, Reading, Mass., 1966.
7. Caldas, M.: Semi-generalized continuous maps in topological spaces, Portugaliae Mathematica., 52 Fasc. 4(1995), 339-407.
8. Cameron, D. E.: Topology atlas., <http://gozips.uakron.deu/>.
9. Cao, J., Ganster, M. and Reilly, I.: Submaximality, extremal disconnectedness and generalized closed sets, Houston J. Math., 24(1998), 681-688.
10. Cao, J., Ganster, M. and Reilly, I.: On sg -closed sets and g^{α} -closed sets, Mem. Fac. Sci. Kochi Univ. Ser. A. Math., 20(1999), 1-5.
11. Crossley, S. G. and Hildebrand, S. K.: Semi-closure, Texas J. Sci, 22(1971), 99-112.
12. Devi, R., Bhuvanawari, K. and Maki, H.: Weak forms of gp -closed sets, where $\rho \in \{\alpha, \alpha^*, \alpha^{**}\}$ and digital plane, Mem. Fac. Sci. Kochi Univ. Ser. A. Math., 25(2004), 37-54.
13. Dontchev, J.: On generalizing semi-preopen sets, Mem. Fac. Sci. Kochi Univ. Ser. A. Math., 16(1995), 35-48.
14. Dontchev, J. and Ganster, M.: On δ -generalized closed sets and $T_{3/4}$ -spaces, Mem. Fac. Sci. Kochi Univ. Ser. A. Math., 17(1996), 15-31.
15. Ganster, M., Noiri, T. and Reilly, I. L.: Weak and strong forms of θ -irresolute function, J. Inst. Math. Comp. Sci. (Math. Ser.) 1 (1) (1988), 19-29.
16. Ganster, M. and Reilly, I. L.: Locally closed sets and LC-continuous functions, Internat J. Math. Sci., 12(3)(1989), 417-424.
17. Kong, T., Kopperman, R. and Meyer, P.: A topological approach to digital topology, Amer. Math. Monthly. 98(1991), 901-917.
18. Levine, N.: Generalized closed sets in topology, Rend. Circ. Math. Palermo, 19(2)(1970), 89-96.
19. Levine, N.: Semi-open sets and semi-continuity in topological spaces, Amer. Math. Monthly, 70(1963), 36-41.
20. Levine, N.: Some remarks on the closure operator in topological spaces, Amer. Math. Monthly., 70 (5) (1963), 553.
21. Maki, H., Devi, R. and Balachandran, K.: Associated topologies of generalized α -closed sets and α -generalized closed sets, Mem. Fac. Sci. Kochi. Univ. Ser. A. Math., 15(1994), 51-63.
22. Mashhour, A. S., Abd El-Monsef, M. E. and El-Deeb, S. N.: On precontinuous and weak pre continuous mappings, Proc. Math. and Phys. Soc. Egypt, 53(1982), 47-53.
23. Navalagi, G. B.: Semi generalized separation axioms in topology, Atlas (internet).
24. Njastad, O.: On some classes of nearly open sets, Pacific J. Math., 15(1965), 961-970.
25. Noiri, T., Maki, H. and Umehara, J.: Generalized preclosed functions, Mem. Fac. Sci. Kochi Univ. Math, 19(1998), 13-20.
26. Rajamani, M., and Viswanathan, K.: On α gs-closed sets in topological spaces, Acta Ciencia Indica, XXXM (3)(2004), 21-25.
27. Ravi, O., Antony Rex Rodrigo, J., Ganesan, S. and Kumaradhas, A.: \ddot{g}^{α} -closed sets in topology (submitted).
28. Ravi, O., Ganesan, S., and Chandrasekar, S.: Almost α gs-closed functions and separation axioms (submitted).
29. Sheik John, M.: A study on generalizations of closed sets and continuous maps in topological and bitopological spaces, Ph.D Thesis, Bharathiar University, Coimbatore, September 2002.
30. Stone, M.: Application of the theory of Boolean rings to general topology, Trans. Amer. Math. Soc, 41(1937), 374-481.
31. Veera Kumar, M. K. R. S.: \hat{g} -closed sets in Topological spaces, Bull. Allahabad Math. Soc., 18(2003), 99-112.
32. Veera Kumar, M. K. R. S.: Between semi-closed sets and semi pre-closed sets, Rend Istit Mat. Univ. Trieste Vol XXXII, (2000), 25-41.

Decomposition of Continuity Using $g^\#$ -Closed Sets

¹O. Ravi, ²S. Ganesan and ³R. Latha

¹Department of Mathematics, P. M. Thevar College, Usilampatti, Madurai District, Tamil Nadu, India.

E-mail: siingam@yahoo.com

²Department of Mathematics, N. M. S. S. V. N College, Nagamalai, Madurai, Tamil Nadu, India.

E-mail: sgsgsgsgsg77@yahoo.com

³Department of Mathematics, Prince SVP Engineering College, Ponmar, Chennai-48, Tamil Nadu, India.

E-mail: ar.latha@gmail.com

Abstract -- There are various types of generalization of continuous maps in the development of topology. Recently some decompositions of continuity are obtained by various authors with the help of generalized continuous maps in topological spaces. In this paper we obtain a decomposition of continuity using a generalized continuity called $g^\#$ -continuity in topology.

Key words and Phrases: \tilde{g} -closed set, $g^\#lc^*$ -set, $g^\#$ -continuous map, $g^\#lc^*$ -continuous map.

1. Introduction

Different types of generalizations of continuous maps were introduced and studied by various authors in the recent development of topology. The decomposition of continuity is one of the many problems in general topology. Tong [7] introduced the notions of A-sets and A-continuity and established a decomposition of continuity. Also Tong [8] introduced the notions of B-sets and B-continuity and used them to obtain another decomposition of continuity and Ganster and Reilly [2] have improved Tong's decomposition result. Przemski [6] obtained some decomposition of continuity. Hatir, Noiri and Yuksel [3] also obtained a decomposition of continuity. Dontchev and Przemski [1] obtained some decompositions of continuity. In this paper, we obtain a decomposition of continuity in topological spaces using $g^\#$ -continuity in topological spaces.

2. Preliminaries

Throughout this paper (X, τ) and (Y, σ) (or X and Y) represent topological spaces on which no separation axioms are assumed unless otherwise mentioned. For a subset A of a space (X, τ) , $cl(A)$

and $int(A)$ denote the closure of A and the interior of A respectively.

We recall the following definitions which are useful in the sequel.

2.1. Definition

A subset A of a space (X, τ) is called:

α -open set [5] if $A \subseteq int(cl(int(A)))$.

The complement of α -open set is said to be α -closed.

2.2. Definition

A subset A of a space (X, τ) is called:

(i) a α -generalized closed (briefly α g-closed) set [4] if $\alpha cl(A) \subseteq U$, whenever $A \subseteq U$ and U is open in (X, τ) . The complement of α g-closed set is called α g-open set;

(ii) a $g^\#$ -closed set [9] if $cl(A) \subseteq U$ whenever $A \subseteq U$ and U is α g-open in (X, τ) . The complement of $g^\#$ -closed set is called $g^\#$ -open.

2.3. Definition [9]

A function $f : (X, \tau) \rightarrow (Y, \sigma)$ is said to be $g^\#$ -continuous if for each closed set V of Y , $f^{-1}(V)$ is $g^\#$ -closed in X .

2.4. Proposition [9]

Every closed set is $g^\#$ -closed but not conversely.

2.5. Proposition [9]

Every continuous map is $g^\#$ -continuous but not conversely.

3. Decomposition of Continuity

In this section by using $g^\#$ -continuity we obtain a decomposition of continuity in topological spaces.

To obtain a decomposition of continuity, we first introduce the notion of $g^\#lc^*$ -continuous map in topological spaces and prove that a map is continuous if and only if it is both $g^\#$ -continuous and $g^\#lc^*$ -continuous.

We introduce the following definition.

3.1. Definition

A subset A of a space (X, τ) is called $g^\#lc^*$ -set if $A = M \cap N$, where M is α g-open and N is closed in (X, τ) .

3.2. Example

Let $X = \{a, b, c\}$ with $\tau = \{\emptyset, \{b\}, X\}$. Then $\{a\}$ is $g^\#lc^*$ -set in (X, τ) .

3.3. Remark

Every closed set is $g^\#lc^*$ -set but not conversely.

3.4. Example

Let $X = \{a, b, c\}$ with $\tau = \{\emptyset, \{c\}, X\}$. Then $\{b, c\}$ is $g^\#lc^*$ -set but not closed in (X, τ) .

3.5. Remark

$g^\#$ -closed and $g^\#lc^*$ -sets are independent of each other.

3.6. Example

Let $X = \{a, b, c\}$ with $\tau = \{\emptyset, \{b, c\}, X\}$. Then $\{a, b\}$ is an $g^\#$ -closed set but not $g^\#lc^*$ -set in (X, τ) .

3.7. Example

Let $X = \{a, b, c\}$ with $\tau = \{\emptyset, \{b\}, X\}$. Then $\{a, b\}$ is an $g^\#lc^*$ -set but not $g^\#$ -closed set in (X, τ) .

3.8. Proposition

Let (X, τ) be a topological space. Then a subset A of (X, τ) is closed if and only if it is both $g^\#$ -closed and $g^\#lc^*$ -set.

Proof

Necessity is trivial. To prove the sufficiency, assume that A is both $g^\#$ -closed and $g^\#lc^*$ -set. Then $A = M \cap N$, where M is α g-open and N is closed in (X, τ) . Therefore, $A \subseteq M$ and $A \subseteq N$ and so by hypothesis, $cl(A) \subseteq M$ and $cl(A) \subseteq N$. Thus $cl(A) \subseteq M \cap N = A$ and hence $cl(A) = A$ i.e., A is closed in (X, τ) .

3.9. Definition

A mapping $f : (X, \tau) \rightarrow (Y, \sigma)$ is said to be $g^\#lc^*$ -continuous if for each closed set V of (Y, σ) , $f^{-1}(V)$ is a $g^\#lc^*$ -set in (X, τ) .

3.10. Example

Let $X = Y = \{a, b, c\}$ with $\tau = \{\emptyset, \{a\}, X\}$ and $\sigma = \{\emptyset, \{a\}, \{b, c\}, Y\}$. Let $f : (X, \tau) \rightarrow (Y, \sigma)$ be the identity map. Then f is $g^\#lc^*$ -continuous map.

3.11. Remark

Every continuous map is $g^\#lc^*$ -continuous but not conversely.

3.12. Example

Let $X = Y = \{a, b, c\}$ with $\tau = \{\emptyset, \{b\}, X\}$ and $\sigma = \{\emptyset, \{b\}, \{a, c\}, Y\}$. Let $f : (X, \tau) \rightarrow (Y, \sigma)$ be the identity map. Then f is $g^\#lc^*$ -continuous map. Since for the closed set $\{b\}$ in $(Y,$

σ), $f^{-1}(\{b\}) = \{b\}$, which is not closed in (X, τ) , f is not continuous.

3.13. Remark

$g^\#$ -continuity and $g^\#lc^*$ -continuity are independent of each other.

3.14. Example

Let $X = Y = \{a, b, c\}$ with $\tau = \{\phi, \{a, b\}, X\}$ and $\sigma = \{\phi, \{a\}, Y\}$. Let $f: (X, \tau) \rightarrow (Y, \sigma)$ be the identity map. Then f is $g^\#$ -continuous but not $g^\#lc^*$ -continuous.

3.15. Example

Let $X = Y = \{a, b, c\}$ with $\tau = \{\phi, \{b\}, X\}$ and $\sigma = \{\phi, \{b, c\}, Y\}$. Let $f: (X, \tau) \rightarrow (Y, \sigma)$ be the identity map. Then f is $g^\#lc^*$ -continuous but not $g^\#$ -continuous.

We have the following decomposition for continuity.

3.16. Theorem

A mapping $f: (X, \tau) \rightarrow (Y, \sigma)$ is continuous if and only if it is both $g^\#$ -continuous and $g^\#lc^*$ -continuous.

Proof

Assume that f is continuous. Then by Proposition 2.5 and Remark 3.11, f is both $g^\#$ -continuous and $g^\#lc^*$ -continuous.

Conversely, assume that f is both $g^\#$ -continuous and $g^\#lc^*$ -continuous. Let V be a closed subset of (Y, σ) . Then $f^{-1}(V)$ is both $g^\#$ -closed and $g^\#lc^*$ -set. As in Proposition 3.8, we prove that $f^{-1}(V)$ is a closed set in (X, τ) and so f is continuous.

References

[1] Dontchev, J. and Przemski, M.: On the various decomposition of continuous and weakly

continuous functions, Acta Math. Hung., 71(1996), No. 1-2, 109-120.
[2] Ganster, M. and Reilly, I. L.: A decomposition of continuity, Acta Math. Hung., 56(1990), 299-301.
[3] Hatir, E., Noiri, T. and Yuksel, S.: A decomposition of continuity, Acta Math. Hung., 70(1996), No. 1-2, 145-150.
[4] Maki, H., Devi, R. and Balachandran, K.: Associated topologies of generalized α -closed sets and α -generalized closed sets, Mem. Fac. Sci. Kochi Univ. Ser. A. Math., 15(1994), 51-63.
[5] Njastad, O.: On some classes of nearly open sets, Pacific J. Math., 15(1965), 961-970.
[6] Przemski, M.: A decomposition of continuity and α -continuity, Acta Math. Hung., 61(1991), 93-98.
[7] Tong, J.: A decomposition of continuity, Acta Math. Hung., 48(1986), 11-15.
[8] Tong, J.: On decomposition of continuity in topological spaces, Acta Math. Hung., 54(1989), 51-55.
[9] Veera Kumar, M. K. R. S.: $g^\#$ -closed sets in topological spaces, Kochi J. Math., 24(2003), 1-13.

DANCE - Data Accordance by Nodal Cloud Emission

SarathChand P.V.^{#1}, Dr.Balraju M^{*2}, Benarji T.^{#3} Bhukya Shankar Nayak^{*4}Thummala Kishore Reddy^{*5}

^{#1, #3}Indur Institute of Eng. & Technology, Siddipet, Medak Dist.A.P. India.

Email: sarathchand2001@yahoo.com, tarini_benarji@yahoo.com

^{*2}Madhira Engineering College, Hyderabad. A.P. India.

Email: jb_raju_cse@yahoo.co.in

^{*4}Prof Madhira Educational society group of Institutions

Email: bsnaik546@yahoo.com

^{*5}Group of Institutions, Hyderabad, A.P. India.

Email: urs_kishorereddy@yahoo.co.in

Abstract - Presently many organizations are adopting and leveraging Data ware house and Business Intelligence for decision making through continuous investments. The Nodal Cloud Emission business necessitates quick and informed decision making. The basic Data retrieval in the data ware house are very primitive with the complex operation that must be performed in various disciplines such as engineering, mathematics and commerce. Although a complex data can be programmed in some programming language, it is desirable to use high level instructions for data retrieval procedure which contains the instructions similar to those required in a particular application. In payroll applications, one wants to manipulate employee records in the master file, performs arithmetic operations, and generates complex data. The cloud Emission technique reduces much of the drudgery of complex data retrievals and reduces new problems. It acts like a program which converts a program to some object language such as a machine language must be written. This technique sometimes acts like a compiler which finally provides the precise definition of the data or for a language.

Generally a language consists of finite or infinite set of sentences. The finite language can be specified by enumerating all their sentences but for infinite languages enumerations is not possible. So any technique which specifies a language or data should be finite. On the other hand the language specifications is to have emission technique which is called as acceptor, to determine whether a given sentence or data belongs to a particular language. This approach is discussed in Nodal Cloud Emission Technique (CET).

Keywords: Metaphor, Syntactic, Regeneration, Acceptor, productions,

1. Introduction

The term cloud is a term associated with a telephony and metaphor for internet applications depicted in network diagrams as an outline of cloud. Many organizations extended these concepts as a detailed in Autonomic computing scenarios. It

describes self monitoring, healing, configuring, optimizing in the management of Data recognitions. The Business Intelligence systems with heterogeneous storages, server applications, networks, security mechanism and other elements which are visualized across the enterprise are described with Cloud mechanism. The Cloud Emission Technique (CET) is the use of internet computer technology for a variety of services. The CET is a different style of computing in dynamically scalable and often virtualized resources provider to the user. It allow workloads to be deployed and give response quickly by virtual machines or physical machines. It also supports self recovering and highly scalable programming models that allows the workloads which can recover from many unavoidable hardware and software failures. The CET monitors the real time enable rebalancing of allocations when are needed. Any sentences in a language such as structure are described in terms of subject, predicate, phrase, and noun and so on. On the other hand for CET the structure is given in terms of procedures, statements, expressions. In many cases it is desirable to describe the structures and obtain a set of all corrected and admissible sentences in the Languages. The Grammatical structure of a particular language helps us to determine whether a particular sentence does or does not belong to the set of correct sentences of Data emissions. It is studied by analyzing the various parts of sentences and their relationships to one another naming as parser.

2. Cloud Emission Technique

The technique of mining is done by considering a particular phrase or a sentence. Let us call a sentence "Mr. Ramu ate the apple". It is parsed by the syntax of the sentence similar to a tree which is called as Emission tree. In this tree each node is represented by a phrase of the sentence. The words such as "the","Ramu" are the basic symbols and

primitives of the language. The syntax of a small subset in the Emission technique can be described by using the symbols

- NP: noun phrase,
 - VP: verb phrase,
 - SP: subject phrase
 - S: sentence, V: verb, O: object,
 - A: article, N: noun.
- The rules to be followed is

- S → SP VP
- SP → AN
- A → Mr
- A → the
- N → Ramu
- N → apple
- N → tree
- VP → VO
- V → ate
- O → NP
- NP → AN

The above rules states that sentence is generally composed of “subject”, “phrase” followed by “verb”, “phrase” which is composed of an “article” followed by a “noun” and a verb phrase is composed of a “verb” followed by an “object”. The structure of the sentence is retrieved by the cloud emission by using the tree structured syntax shown in **Figure1** such as

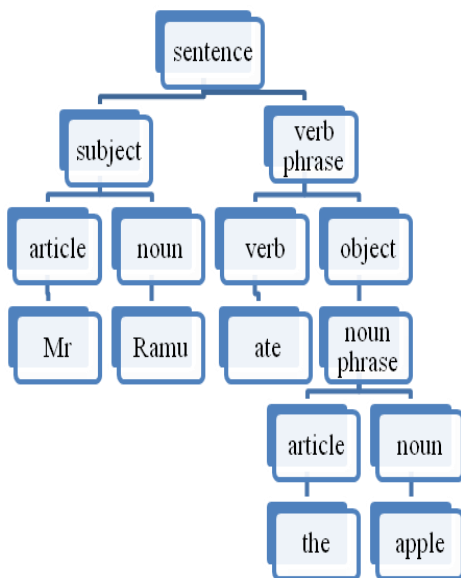

Figure 1

The structure of the language or phrase is represented by syntactic classes of elements. Each syntactic classes consists of a number of alternatives structures and each structure consists of an ordered set of items which are either the

primitives of the language or syntactic classes. These alternative can also be called as rules of predictions. The S → SPVP defines a “sentence” composed of a “subject phrase” followed by a “verb phrase”. The symbol → separates the syntactic class “sentence” from the definition. The syntactic class and the arrow symbol with the interpretation of the productions enable to describe the language. The CET is mainly proposed with the syntax of the language and the device which is defined to give the syntactic definition of the language. It is concerned with using the productions, grammatical rules to produce the syntactically correct sentences or words. If the syntax is correct then it produces the object code.

3. Data Retrieval by Cloud Emission Technique

The CET method specifies a language by using the methods of acceptor. The acceptor is a set of programmed which can identify strings of language. The acceptor is similar to finite state machine which does not have any output alphabets; instead it has a set of acceptance states. The acceptor reads an input from the user in a sequential manner.

3.1 Definition:

An acceptor is 5-tuple notations $\langle I, Q, p_0, \delta, F \rangle$ where I is the set of input words is the finite set of syntactic states, p_0 which belongs to the input words Q and δ is the mapping of $Q \times I$ into the Q , the F is the set of final word retrieved and is subset of Q . Let the state of acceptance be p_0 . The interpretation of $\delta(q, a) = p$, where $(q, p) \in Q$ and $a \in I$, is that M in the state q , the acceptor scans the words or symbols a , and enters to the next position to the right and changes its state to p . The new mapping δ as

$$\delta(p, \Delta) = p$$

$$\delta(p, xa) = \delta(\delta(p, x), a) \text{ for every } x \in I^* \text{ and } a \in I.$$

The string or a sentence is accepted by the acceptor if $\delta(p_0, y) = q$ for some $q \in F$. The set of all such y 's are accepted by the acceptor called as language acceptor. The $L(M)$ is $L(M) = \{ y | \delta(p_0, y) \in F \}$.

The words or sentences accepted by the Language acceptor are regular language. The rule of the acceptor is, to assign the numbers for the words. The numbers should be the natural numbers which are divisible by 3. It can be viewed by the reference numbers, say “Mr. Ramu ate the apple” then “Mr”, “Ramu”, “ate”, “the”, “apple” are $\{0, 3, 6, 9\}$. If the sentence is not retrieved then the natural numbers which are not divisible by 3 is assigned and the acceptor does not recognize, which

indicates the particular sentence or word is not available in the ware house.

Let the Language Acceptor is defined with some sequence of numbers

$L(M) = \langle I, Q, p_0, \$, F \rangle$ where

$I = \{0, 1, 2, 3, 4, 5, 6, 7, 8, 9\}$

$Q = \{p_0, p_1, p_2\}$ and $F[p_0]$.

It is defined as

$\$(p_0, a) = p_0, \$(p_0, b) = p_1, \$(p_0, c) = p_2;$

For $a \in \{0, 3, 6, 9\}$.

$\$(p_1, a) = p_1, \$(p_1, b) = p_2, \$(p_1, c) = p_0;$

For $b \in \{1, 4, 7\}$.

$\$(p_2, a) = p_2, \$(p_2, b) = p_0, \$(p_2, c) = p_1;$

For $c \in \{2, 5, 8\}$.

By using the above probability the language acceptor recognizes the string $\{0, 3, 6, 9\}$.

4. Implementation of CET

The problem of trying to generate a sentence "Mr.Ramu ate the apple". From the production given. It is accomplished starting first with the syntactic class symbol **S** and looking for the productions which are the **S** for the left of the arrow.

1. The only production left from above rules is
 $S \rightarrow SP VP$
2. We have replaced the class **S** by the only possible compositions
SP VP
3. Look for the production on the left hand side is
SP
4. Replace it with the right hand side of that production.
5. It produces **AN VP**
6. Now look for the productions left for **A** and two such productions are found **Mr, the**
7. If **Mr** is substitute then the productions is **MrN VP**.
8. The process is continued until we arrive the correct sentence.
9. The complete generation is as follows

$S \rightarrow SP VP$
 $\rightarrow AN VP$
 $\rightarrow MrN VP$
 $\rightarrow Mr Ramu VO$
 $\rightarrow Mr Ramu ate O$
 $\rightarrow Mr Ramu ate NP$
 $\rightarrow Mr Ramu ate A N$
 $\rightarrow Mr Ramu ate the N$
 $\rightarrow Mr Ramu ate the apple.$

The above rules can produce a number of sentences like

Mr Ramu ate the apple.

Mr Ramu climbs the tree.

The apple ate Mr Ramu

These sentences are grammatically correct, does not really make sense. The situation is often followed in the specifications of the languages. There are many kinds' valid languages like FORTRAN and PL/I that do not make sense. It is very easy to define a Language Acceptor if certain sentences of questionable validity are allowed by the rewriting rules and regulations.

4.1 Theorem

Let X be a set containing n elements and X^* denote the some of the semi group generated by X and then let (S, \oplus) be any other semi group generated by any n generations, then tere exists a sentence $g: X^* \rightarrow S$

Proof

Let Y be the set of generations of S . Let $g: X \rightarrow Y$ may be one to one mapping given by the $g(x_i) = y_i$ for $i=1,2,3,4,5\dots n$.

Now for any string $\alpha = x_1 x_2 \dots x_m$ of X^* then

$g(\alpha) = g(x_1) + g(x_2) + \dots + g(x_m)$

then

$\alpha\beta \in X^*$

$g(\alpha\beta) = g(\alpha) + g(\beta)$ then

g is the required sentence

4.2 Programming Algorithm:

1. Enter the string name1;
2. gets (name1);
3. Check (name2);//name2 is a string available in the ware house
4. i=0;
5. While (name1 [i] == name2 [i] && name2 [i] != '\0')
6. i++;
7. if (name1[i]==name2[i])
8. String is found
9. else Repeat the step 5
10. End.

The cloud Emission technique increases the number of searching to retrieve the sentence as shown in the **Figure2**

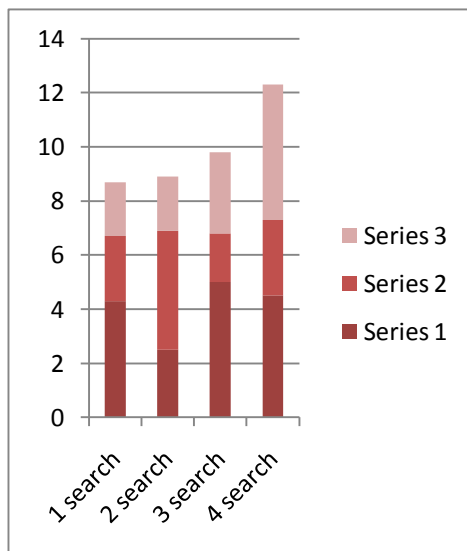

Figure 2

5. Conclusion and Future Work

The comprehensive Data Warehouse that integrates operational values with customers, suppliers and market information has resulted in the explosion of data. The market competition requires sophisticated analysis on an integrated view of warehouse. By this there is a growing gap between the storage and retrieval systems and the availability of the user's ability to effectively analyze and act on the information. A new technological leap is needed to structure and prioritize information for specific end user problems. The Cloud Emission Technique make this leap. Quantitative business benefits can be proven through the integration of data warehouses and Cloud Emission Technique and the new products are on the horizon that will bring this integration to an even wider for the sake of users. In future the business intelligence tools would have the capability to analyze the CET as they come in. It compare the data against some baseline and generate alerts or provide the information. The meaning of this is, CET would be able to run on top of the transactional database and also provides the convenient methods for real time analysis on transactional data. In future the Object Oriented Models and UML models also need to be available in the CET especially in science and engineering applications of data warehouse. The future would result in both the convergence and standardization of the CET for Data Warehouse.

References

- [1]. <http://www.google.com> for study materials.
- [2]. Infosys foundation programs me powered by intellect driven by values.

- [3]. 5 Mar 2011 Search Results for nuclear cloud the nether lands 2011 Virgen de las Nieves at Granada found that the metabolic imaging diagnosis technique based on the analysis ... 10.19.2010 · Posted in Cancer Grants, Publications ... (TOF) positron emission tomography (PET) scans can improve cancer detection.
- [4]. Discrete Mathematical Structures with Application to Computer Science by Trembley and Manohar.
- [5]. 20 Sep 2010 ... "With this technique all of the gases that have absorption bands in the ... February 2011 January 2011 December 2010 J.M.Smith et al "Multibase integrated heterogenous." "Distributed Database systems"
- [6]. IBM recently published it's 2010 Global Risk Study and the findings horizonwatching.typepad.com/horizonwatching/cloud-computing
- [7]. Cloud Book. by Richard Hamblyn. Search the Guardian bookshop.
- [8]. 16 Jun 2009 ... New instrument for measuring magnetic-field tilt profile and pellet clouds emission structure

Author Biographies:



Prof.P.V.SarathChand B.E(C.S.E),M.Tech(CS),and pursuing PhD(CSE).He is having 14 years of Teaching Experience. He is working as a Professor and Head of I.T Dept for Indur Institute of Engineering and Technology,Siddipet, Medak, Dist.



Dr.M.BalRaj B.E(E.C.E),M.Tech(CSE),PhD(CSE) and having 19 years of Teaching Experience. He is working as a Principal for Madhira Educational society group of Institutions (integrated campus), Hyderabad.



Mr.Bhukya Shankar Nayak B.Tech(C.S.E) from JNTUniversity Hyderabad and M.Tech (C.S.E) from IIT Madras, Chennai. Presently working as a Assoc. Prof & Head of the department of Computer Science & Engineering at Madhira Educational society group of Institutions. He is having 7 years of teaching.



Thummala Kishore Reddy B.Tech (C.S.E) and M.Tech (C.S.E) from JNTUniversity Hyderabad. Presently working as an Asst.Professor in the Department of Computer Science & Engineering at CMR GROUP OF INSTITUTIONS. He is having 3 years of teaching experience.



T.Benarji received M.Sc (CS) and M.Tech (CSE). He is currently pursuing PhD degree in CSE and having 7 years of Teaching Experience. His area of interest is in Text Mining and Information Retrieval. He is working as an Associative Professor in the Department of I.T in Indur Institute of

Engineering and Technology, Siddipet, A.P, India

Mathematical Analysis of Data Mining in Higher Education

M.P.Chaudhary^{1,*}, Kriti Gupta², Alpana Jijja² and Rajan Vohra³

¹. American Mathematical Society, USA

². Ansal Institute of Technology, Gurgaon, Haryana, INDIA

³. Krishna Institute of Engineering and Technology, Ghaziabad, INDIA

e-mail:mpchaudhary_2000@yahoo.com

Abstract: The purpose of this research paper is to describe to how an academic institution can expand its data analysis capabilities through the use of data mining techniques by considering example of an engineering institute. The benefits of this data analysis are also enumerated in this paper.

Keywords: Customer relationship management, Decision support system, Online analytical processing, Data mining, Data warehousing, Data marts, Enterprise resource planning, etc.

1. Introduction

In India higher education is currently undergoing a radical change, customer relationship management helps students with their choices and decisions by communicating to them the right information, and also provides the institutes with information resources to manage and run their academic programs better than their competitors.

This makes the system more interactive in respect to their “customers: students, alumni, faculty members and staff members”. Kotler & Fox stated as “The best organization in the world will be ineffective if the focus on “customers” is lost”[1].

Higher education is a level of education provided by the universities, colleges, and institutes to the student to attain specialization in various fields after completing their primary education.

In the field of higher technical education the major challenge faced by the institutes is to compete successfully. It is important to adopt best practices, which enable them to personalize the system. In today’s scenario when the technology is changing rapidly, the needs of students and institutes are also changing. Institutes are looking to improve their conversion ratios from prospect to enrolment, want to restructure their operating processes to cut costs and improve and optimize their internal business processes - student information, human resource, finance, etc.

Our main focus is to restructure and re-engineer our current traditional MIS system that is overloaded with information, by automating and improving processes like front office interaction,

enrolment, marketing, customer service and support. This is only possible by implementing Customer Relationship management (CRM) and Enterprise Resource Planning (ERP) for decision support. CRM will help the institute to develop and manage relationships with different constituents, while ERP software will help our institute to communicate with its prospective students, current students, faculty and alumni through portals, and manage the entire student lifecycle - admissions, registration, student-records, financial aid, fiscal management, HR/payroll, projects and alumni relations, i.e., management of the academic and administrative services.

The ERP solution offers improved services for faculty, staff, and students. Administrative and academic data of student are standardized and stored in a central repository. College information will be accessible over the Internet and the new systems will improve efficiency with respect to legacy systems.

In this research paper we are going to describe our model through the data of Ansal Institute of Technology.

1.1. About Ansal Institute of Technology (AIT)

AIT is a private educational institute situated in Gurgaon, Haryana. It is affiliated to Guru Gobind Singh Indraprastha University (IP University), and was established in the year 2000 under the Chiranjiv Charitable Trust. AIT is located in sector 55 of Gurgaon in the foothills of Aravallis and in close proximity of offices of major Multinational Companies. The college offers various academic programmes with an intake of 600 students per annum. The institute has close to 120 faculty members teaching in various departments. [2]

Table 1: Total number of students in AIT

Programme	Branch	Strength
B.Tech. (4 year)	Computer Science & Engineering (CSE)	120
	Information Technology (IT)	60
	Electronics & Communication Engineering (ECE)	120
	Electrical & Electronics Engineering (EEE)	60
Total seats	360	
BCA (3 yr)	Bachelor of Computer Application (BCA)	60
BBA (3 yr)	Bachelor of Business Administration (BBA)	120
BBAB (3 yr)	Bachelor of Banking and Insurance (BBI)	60
Total Seats	240	

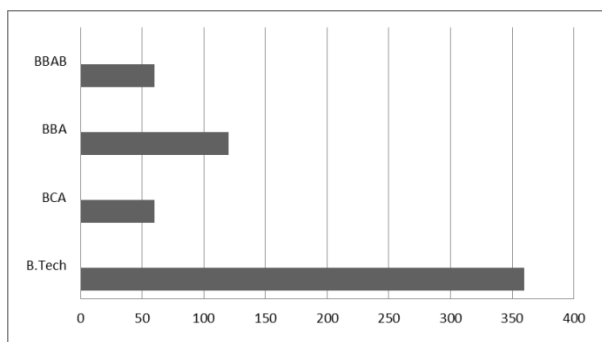

Figure1: Number of Students in the different programs

The course curriculum at AIT has been designed considering industry as an important stakeholder in the education process. For that the institute conducts industrial trainings, visits, seminars and conferences regularly.

The entire campus of the institute is connected through a Local Area Network (LAN) with a backbone of office, supporting a network of 1250+ nodes. The computer laboratories, faculty computers and administrative offices are all networked. The institute has high-speed internet connectivity through a 6 Mbps leased line on optical fibre. The hostels in the institute campus are provided connectivity through optical lines and Wi-Fi connectivity is also available throughout the campus.

The institute has an academic alliance with Microsoft to provide operating systems, servers and application software. The labs offer access to the required computer resource for the students, staff and faculty. It can be seen from Fig.

1 that B. Tech. Students form the majority of prospective students.

1.2. ERP in Education

Enterprise Resource Planning (ERP) systems have been applied to industries to support financial accounting, procurement, human resources, customer service management and supply chain management processes. ERP system is a solution that addresses the enterprise needs taking the process view of an organization to meet the organizational goals by firmly integrating all functions of an enterprise. The objective of an ERP system is to integrate all departments and functions across an organization onto a single computer system that can serve specific needs of all the departments. In recent times, ERP is increasingly being implemented in new industry areas like higher educational institutes. An effective approach of ERP is required to upgrade and improve procurement, accounting, management and customer service processes in higher educational institutes [3] and [4].

Benefits of ERP

- Improves access to the information.
- Gives timely and accurate information.
- Increases the efficiency of employees and reduces the dependency on paper.
- Provides user-friendly web-based interfaces.
- Improves communication between various departments.

Limitations of Transactional Applications

- Designed for real-time data entry and editing.
- Data maintained is constantly changing.
- Limited historical data is available for on-line comparisons
- Running decision support queries degrades the performance of the transaction applications.
- Difficulties in making ad-hoc queries.
- Complexity in achieving comparisons, aggregations, ranking, running totals etc [12].

Data are typically not stored for an extended period on Online Transaction Processing (OLTP), for storage cost and transaction speed reasons. Online Analytical Processing (OLAP) has a different mandate from OLTPs. OLAPs are designed to give an overview analysis of what happened. Hence the data storage (i.e. data modelling) has to be set up differently. OLAP is used due to increase in data volumes for large organisations. It will allow a user to slice and dice

data at will. It uses multidimensional data modelling for strategic decision making in large organisations. It also helps in daily decision making in any size of the organization. OLAP implementation process involves abstracting data from various data repositories and making them compatible. The limitations of ERP systems increased the need for OLAP systems.

Standard two-dimensional reports of transactional data proved inadequate to drive effective business decisions. So the steps towards analytical solutions were executive information systems (EIS), decision support systems (DSS), on-line analytical processing (OLAP) and data mining to make business sense out of the increasing volume of transaction-level data. DSS capabilities help us to gain knowledge through the process of all departments within an organization.

The analysis of the CRM data helps each department focus on the key aspects of customer

make resulting in improved customer satisfaction. This process is illustrated in Fig. 2 above.

1.3. Customer Relationship Management (CRM)

Customer Relationship Management (CRM) is both a business strategy and a set of discrete software tools and technologies, with the goal of reducing costs, increasing revenue, identifying new opportunities and channels for expansion, and improving customer value, satisfaction, profitability, and retention. CRM software applications embody best practices and employ advanced technologies to help organizations achieve these goals. The focus of CRM is on automating and improving the institutional processes associated with managing customer relationships in the areas of recruitment, marketing, communication management, service, and support.



Figure 2: Automated processes extract data from OLTPs [5]

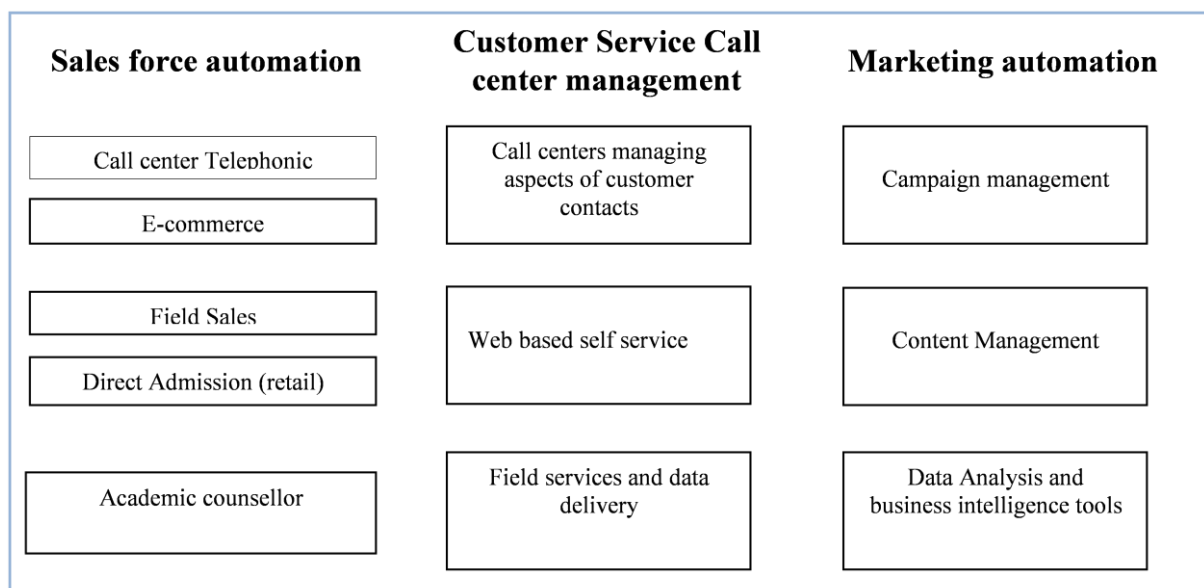

Figure3: Elements of CRM [9]

management that they impact, from acquisition to retention. The analysis will allow users to track financial and operational performance for a specific customer or across all customers. In the end, the more informed each department is regarding the customer acquisition, retention and growth processes, the more effective decisions they will

As seen in Fig. 3, the deployment of Data Analysis and Business Intelligence (BI) Tools helps an institute to employ Data mining techniques to obtain strategic information that is used for decision support.

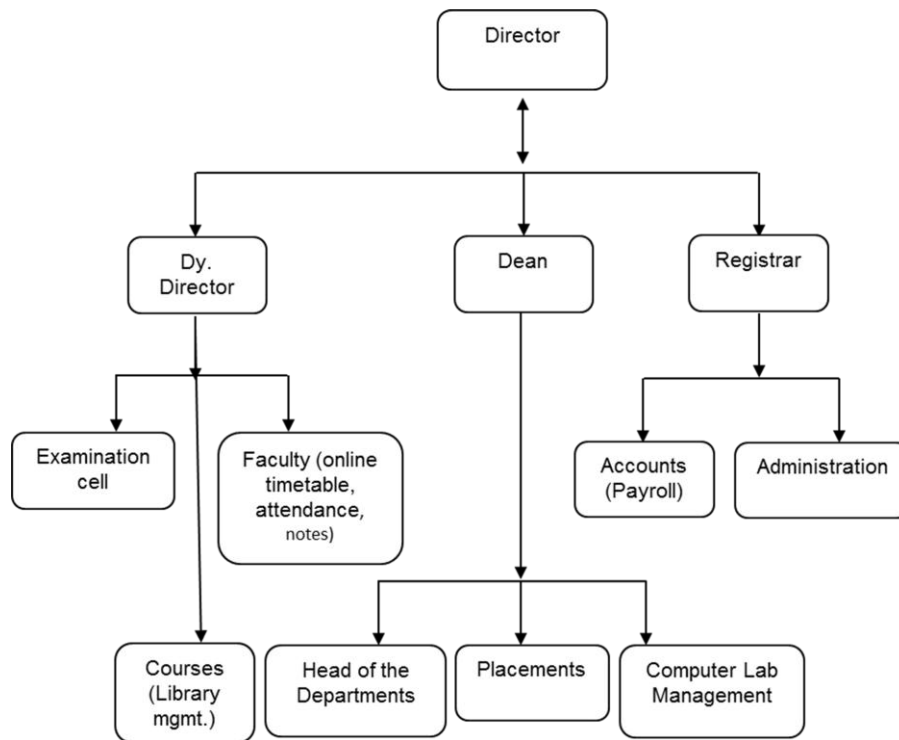

Figure 4: Present IT structure at AIT

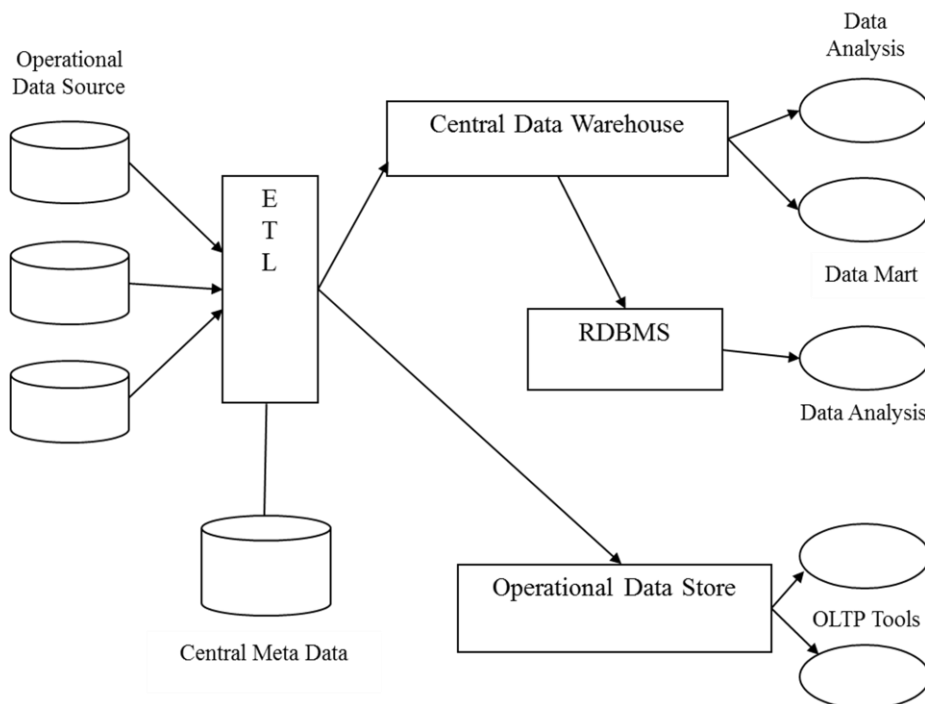

Figure 5: Enterprise Data warehouse Architecture

CRM takes a very customer-centric view of the entire customer life cycle, which means that a CRM business strategy places the customer at the center of the organization's universe. In the context of an educational institute, from the perspective of the customer, a CRM business strategy allows interaction with the college or university from a single entity that has a complete understanding of

their unique status. In the case of a student, this might be seen through the interaction with and between the admissions, registration, financial aid, student accounts, and housing offices. For a faculty or staff member, a CRM business strategy would optimize interaction with departments administering benefits, payroll, staff training, information technology (IT), or facilities. From the

perspective of the college or university, the CRM business strategy provides a clear and complete picture of each individual and all the activities pertaining to the individual [1].

2. Management Information System in AIT

2.1. The Current System:

As we are aware,

2.2. The Proposed Architecture (Enterprise Data Warehouse Architecture)

Figure 5, presents an Overview of Data Warehousing Methodologies is discussed by Sen and Sinha [10]. The above figure illustrates the Enterprise Data Warehouse Architecture, which maintains a Central Data Warehouse in an Enterprise Architecture, with operational Data Stores. This Central Warehouse can be queried for Analytics.

2.3. Three Tier Data Warehouse Architecture

The required Data Analysis is done at the top tier while the input data comes from the operational databases in the bottom tier.

3. Applications of Data Analysis in Higher Education

- 1. Student segmentation:** Analysis of student segmentation plays a very important role in higher education. The main objective of student segmentation is to segregate the students on the basis of criteria like academic profile of student, family income, urban/rural area they belong to, educational background of family, student inclination, etc. This will help us to develop new teaching methods and tools for specific groups as well as finding out the gap in student performance and plan target marketing, both at entry level and on a continuous basis.
- 2. Framing of HR Policies:** The growth of higher education in India has increased the need for well-qualified faculty. The prime concern for the educational institutes is to recruit and retain highly qualified faculty

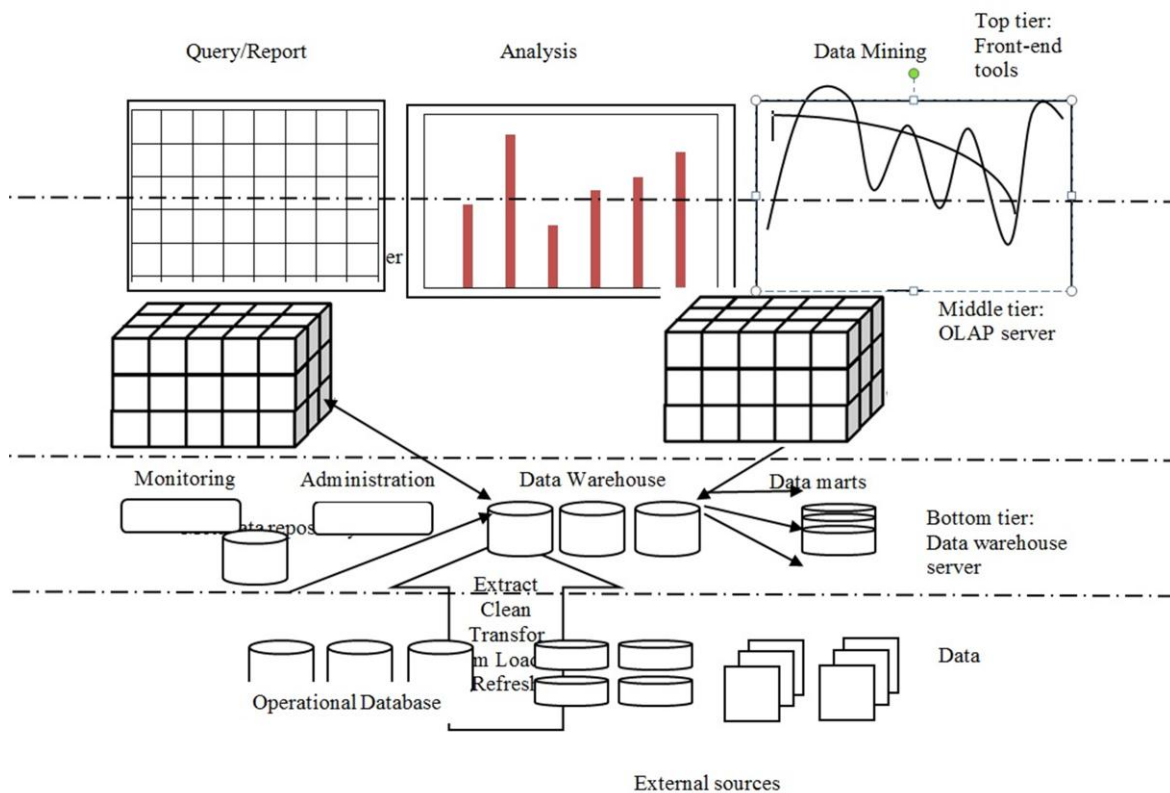

Figure 6: Three-Tier Data Warehouse Architecture [12].

members. The more experienced and more qualified the faculty; the better is the

reputation of the institute. The tenure of stay of a faculty member in an educational institute is directly correlated to his/her satisfaction with the HR policies of the institute. To address this issue we need to introduce HR tools. We need to keep records of the faculties – designation, qualification, research work, achievements, experience, compensation package etc., for effective and transparent performance evaluation and appraisal system. If faculty members are given the right salary and the right designation according to their experience and qualification, then satisfaction and motivation factor will be high. This will enable the institute to retain its faculty in coming years. This in turn will make the institute more appealing to scholars when filtering their choice for institutes, thereby ensuring that the institute attracts more academically inclined students on its rolls.

3. Identification of Student Outliers:

Statistically, outlier is an observation, which is numerically distant from the rest of the data. In higher education, finding out the students who are not performing well in exams, not attending the classes, not submitting the assignments, not paying fees in time can be termed as outliers. For proper monitoring of outlier students we need to keep records of quizzes, assignments, attendance, fees etc. Software alerts can be used which will help us to keep a check on the outliers. Data Analysis from this system will enable tracking of outlier students and devising suitable policies.

4. Campaign management: In higher education, it is a process for the institutions to develop and deploy multi-channel marketing campaigns (print media, radio, television, internet, workshops, and road-shows) to target future students, alumni, donors etc. Publicity can help us enroll students with a better academic profile, which will improve the reputation of the institution. Target marketing can be done in promising areas with the help of this system. Linking this analysis with local demographic data can also identify future markets.

5. Course data analysis: It includes analysis of students who had taken this course previously. Analysis will include relevance of the course in finding job opportunities, how course is linked to the other courses, what will be the orientation of career after this course. It will benefit the future student to understand the benefits of the course and will help them make an informed decision before selecting the course, along with suitable electives and projects and relevant technologies. The

academic performance of the institute can also be tracked.

6. Placements Data Analysis: Here we will be analyzing the number of companies approached for campus recruitment every year, number of companies visiting the campus for recruitment, number of students recruited, company and student profile, industrial visits, industrial training of students in various organizations, summer courses attended by students, alumni database etc. This analysis is intended to build placement campaigns for students in the future.

7. Admission Data Analysis: Admission Analysis can be done by analyzing the records of previous year data by keeping following factors in mind:-

- Academic profile of a student
- Defining Cut-off percentage for admission
- Segregation of the student by
 - Location
 - Financial profile
 - Academic profile
 - Type of School attended

Also, students needing financial aid can be identified through this data analysis.

8. Research and projects development Data Analysis:

Research plays a major role in the academic growth of any institution. Research work and projects done by an institute provide information about the quality of the education imparted, as increased stress is being placed on outcome based learning. Hence we need to keep records of projects/research done by students/faculty, future research scope in different areas, and records of the research publications. This enables local government to devise suitable funding policies for institutes in the region.

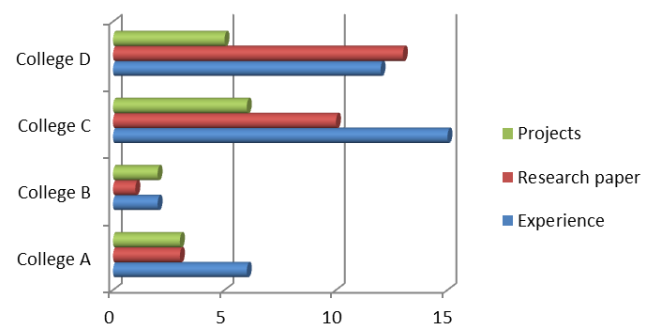

Figure 7: Research and project development data analysis

9. Entrepreneurship Data Analysis: In today's dynamic globalised economic environment

students are showing a high preference to opt for entrepreneurial endeavours after their graduation. The amount of entrepreneurial activity by the students of an institute is perceived to be an indicator of the quality of education imparted at the institute. Hence an institute also needs to keep a record of entrepreneurial activities being undertaken by its current as well as former students. The relevant analysis can be the number of students opting for entrepreneurial ventures after graduation, the academic programs in which these students are enrolled, the areas in which students are entering as an entrepreneur, etc. This will prove to be an asset to the institution in future recruitment planning and planning of new academic program.

4. Discussion

The Table below shows existing and proposed functionality for various stakeholders in the system.

Table 2: Comparative study of Present and proposed structure

S. No.	Stakeholder	Functionality	
		Existing (OLTP)	Proposed (OLAP)
1.	Faculty	Online Time table	Which Faculty member have excess teaching load.
		Online attendance	How many students are short of minimum attendance required?
		Online Documents	How many students have submitted assignments?
		Online result	Result analysis for eg. Cut off, number of first class students, number of outlier students.
2.	Students	Online Time table	Total free slots per week for a class.
		Giving Feedback	Number of teachers with negative feedback from students.

		Online teaching aid	
		Online result	Student segmentation by results obtained and skill sets.
3.	Accounts	Calculate Salary	Total tax paid by staff, Savings profile of staff.
		Maintain Expenditure of college	Expenditure profiling.
		Student fees record	Students needing financial aid, Alerts on overdue fee.
4.	Library	Issue book	Borrowing pattern of students.
		Returning of book	
		New book purchase	Expenditure profiling on books
		Keeping records of Journals	Intelligent inventory management, e.g., Reorder level
5.	Transport	Maintain book bank	
		Decide the bus route	Identify revenue rich route
		Check no. of student per route	Optimize route planning
6.	Hostel	Bus fees	Discard outliers routes
		Keeping track on no. of student	Hostel room and bed allocation
		Maintenance of hostel	Profiling hostel inmates by region, course, and financial status.
7.	Management	Daily attendance	
		Mess records	Menu profiling for mess
		House keeping records	Inventory Control
7.	Management	Decision	Revenue

		making and Controlling	profiling Student profiling Identifying new regions\markets Planning for new programs Demographic data analysis
--	--	------------------------	---

The above table describes the functional capabilities of the proposed system. After identifying these features, suitable data mining techniques can be deployed to capture and build this strategic information base.

Table 3: Sample of applications along with respective Data Mining Techniques

S. No.	Application	Data Mining Techniques
1.	Student Segmentation	Cluster Analysis
2.	Student Acquisition	Decision Trees
3.	Profitability Analysis	Decision Trees, Linear Regression
4.	Inventory Control	Decision Trees, Linear Regression.
5.	Campaign Management	Regression, Decision Trees
6.	Outlier Analysis	Cluster Analysis
7.	Financial Aid Analysis	Decision trees

A sample of applications along with respective Data Mining Techniques is given in the above table. This illustrates the application of different Data Mining techniques for diverse business applications with respect to an academic institute.

5. Conclusion and Direction of Future work

The use of data mining generates strategic information, which is of immense commercial value to all the stakeholders of such academic institutes. In particular each wing of the institute benefits immensely that is: Marketing, Accounts, Faculty, Students, Stores, Admission cell and above all the owners of the institute.

This research paper notes the absence of data analysis software and capabilities at the Institute. It proposes an architectural frame work for implementing data analysis through the use of data mining techniques. It identifies key application areas, which can benefit by the use of Data Mining (DM) techniques.

In further work, each such area can be analysed in a separate research paper and results of

such analysis can be presented for suitable input data.

Acknowledgement: One author (MPC) of this paper is grateful to the faculty members and library staff of CRM, Marseille, France, EUROPE for their cooperation and excellent academic facilities during his visit in winter 2010.

References

- 1 Gary B., Grant and Greg, Anderson; *Customer Relationship Management: A vision for Higher Education*, Wiley and Sons, (2002), 23-32.
- 2 Ansal Institute of technology: Admission Brochure, (2010).
- 3 Mary, Jo Davis and Zhenyu, Huang; *ERP in Higher Education: A Case Study of SAP and Campus Management*, Issues in Information Systems, Vol. VIII, No.1, (2007).
- 4 Ana, Ramona and Mihaela, Mutean; *Higher Education ERPs, Implementation Factors and their Interdependencies*, Vol.8 (4), (2009).
- 5 Hari, Mailvaganam; *Introduction to OLAP*, Data Warehousing Review e-magazine, (2007),
- 6 Jayanthi, Rajan; *Applications of Data Mining Techniques in Pharmaceutical Industry*, Journal of Theoretical and Applied Information Technology, (2007), 61-67.
- 7 Feelders, A., Daniels, H. and Holsheimer, M., *Methodological and Practical Aspects of Data Mining*, Information and Management, (2000), 271-281.
- 8 Hand, David, Mannila, Heikkin and Smyth, Padhaic; *Mining of Frequent Patterns Identifies Rules of Affinities Among Collection of Data*, Applications of Association Rules include Market Analysis, Principles of Data Mining, The MIT Press, (2001), 9-10.
- 9 Robin A., Robinsons; *Quick Study : Customer Relationship Management (CRM)*, Computerworld e-magazine, 41519.
- 10 Sen, A. and Sinha, A. P.; *A Comparison of Data Warehousing Methodologies*, Communication of the ACM, Vol.48(3), (2005), 79-84.
- 11 Chaudhary, S. and Dayal, U, *An Overview of Data Warehousing and OLAP Technology*, SIGMOD Record, Vol. 26(1), (1997), 65-74.
- 12 Jiawei, Han and Micheline, Kamber; *Datawarehouse Architecture (A 3 tier datawarehousing architecture)*, Data Mining Concepts and Techniques, 2nd Edition, (2006), 109-132.

- 13 Andrzej, Ceglowski, Leonid, Churilov and Jeff, Wassentheil; *The Nature of Work in an Emergency Department of a Hospital was Studied using Cluster Analysis. Knowledge Discovery through mining Emergency Departemnt Data*, Proceeding of the 38th Hawaii International Conference on System Sciences, (2005), 1-9.
- 14 Harlien, Kaur and Shri Krishana, Wasan; *Empirical Study on Applications of Data Mining Techniques in Health Care*, General of Computer science, Vol. 2(2), (2006), 194-200.
- 15 Shams, K and Frashita, M.; *Data Warehousing Towared Knowledge Management*, Topics in Health Information Management, (2001).

Growing Hierarchical Adaptive Self-Organizing Map for Phoneme Classification

Chiraz Jlassi, Najet Arous, Noureddine Ellouze

Ecole Nationale d'Ingénieurs de Tunis

BP 37, Belvédère 1002 Tunis, Tunisie

Chiraz_jlassi@yahoo.fr

Najet.Arous@enit.rnu.tn

n.ellouze@enit.rnu.tn

Abstract: The self-organizing map (SOM) is an unsupervised neural network providing a mapping from a high-dimensional input space to a one or two-dimensional output space while preserving topological relations as faithfully as possible. This model has been widely used due to its powerful visualization properties, and despite some of its intrinsic limitations, static nature in terms of map size and the fact that the size must be determined prior to training. To address both issues within one framework, a neural network model of the growing hierarchical self-organizing map (GHSOM) was introduced. The GHSOM is a highly adaptive architecture regarding both the map size and the depth of the hierarchy. Especially the adaptive growth process of a trained GHSOM is reasonable with respect to unevenly distributed input data. The training and growth process is guided solely by the desired data representation granularity. The computational load is also reduced due to the hierarchical structure. In this paper, we propose some variants of unsupervised and competitive learning algorithms. These algorithms are based on the growing hierarchical self-organizing map. The first variant named "GHAdSOM" (growing hierarchical adaptive self-organizing map) is characterized for each unit of each map of the hierarchy by a locally adapting neighborhood radii and multiple prototype vectors. The second variant is a hierarchical model which represents a multi-layer extension of GHAdSOM model. The case study of the proposed GHSOM variants is phoneme classification in continuous speech and speaker independent. The proposed GHSOM variants show good robustness and high phoneme classification rates.

Keywords: Adaptive learning, Growing hierarchical self-organizing model, Neighborhood radii, Multiple prototype vectors, Decision system, Phoneme classification.

1. Introduction

Different recognition systems have been proposed in the literature [4]. Some of them are based on hidden markov models (HMM) others are based on neural networks (NN) architecture, hybrid systems (HMM and NN) have also been proposed...

Neural networks have been traditionally considered as an alternative approach to pattern recognition in general and speech recognition in particular. There has

been much success in particular pattern recognition applications using neural networks including multi-layer perceptrons, radial basis functions and self-organizing map (SOM) [1], [2]. Despite its wide applications, the SOM analysis has its inherent deficiencies. First, it uses a static network architecture that has to be defined prior to the start of training. Second, hierarchical relations between the input data are difficult to detect in the map display. On the other hand, in a conventional SOM, the number of neurons needed by the learning process increases exponentially with the size of the input vector. The full-search algorithm has a complexity of $O(n)$, where n is the number of neurons. A search algorithm with $O(\log n)$ complexity can be obtained if the neurons are arranged in a tree. Many models of hierarchical SOMs were proposed and several developments on the basic algorithm of the SOM have addressed the issue of adaptive SOM structures; amongst them: dynamic self organizing maps [5], incremental grid growing [6], or growing grid [7], when new units are added to map areas when the data are not represented at a satisfying degree of granularity.

To address both issues within one framework, a neural network model of the growing hierarchical self-organizing map (GHSOM) was introduced [9]. The GHSOM is composed of independent SOMs, each of which is allowed to grow in size during the training process until a quality criterion regarding data representation is met. This growth process is further continued to form a layered architecture such that hierarchical relations between input data are further detailed at lower layers of the neural network.

In this paper, we describe voiced phoneme classification by means of a new variant of GHSOM, characterized for each unit by a locally adapting neighborhood radii and multiple prototype vectors; the proposed GHSOM variant is named "GHAdSOM" [23]. The input of the GHAdSOM is a sequence of 12 mel cepstrum coefficients vectors. Each output unit of the GHAdSOM is described by a general centroid vector and other information describing all classes visited by a map unit using the method of information

enrichment [21], [22]. The contribution of this work is to design a hierarchical model which represents a multi-layer extension of GHAdSOM model. The purpose of the proposed system is to create autonomous systems that can learn independently and cooperate to provide a better decision of the phoneme classification.

In section 2, we present the self-organizing map by detailing its sequential learning process. In section 3, we review hierarchical SOM models. In section 4, we explain the principles of the basic growing hierarchical self-organizing map algorithm. In Section 5 and 6, we propose GHSOM variants. And finally in section 7 we illustrate experimental results of the application of GHSOM variant on phoneme classification of TIMIT speech corpus.

2. The self-organizing map

The most famous model of the self-organizing map is the Kohonen map. Its principal application is the automatic speech recognition [3].

The self-organizing map output represents the result of a vector quantization algorithm that gives a fixed number of references or prototype vectors onto high-dimensional data sets in an ordered fashion. A mapping from a high dimensional data space (\mathfrak{R}^n) onto a two dimensional lattice of units is thereby defined. The topology of this mapping is described by: dimensions (map size), lattice (hexagonal or rectangular) and shape of the map grid (sheet, cylinder or toroid). Before training of the SOM, initial values are given to prototype vectors. Hence, a parametric reference vector $m_i \in \mathfrak{R}^n$ is associated to every unit i . An input vector $x \in \mathfrak{R}^n$ is compared with all m_i , in any metric; in practical applications, the smallest of the Euclidian distances is usually used to define the best-matching unit (BMU). The BMU is the neuron whose weight vector m_i is closest to the input vector x determined by:

$$\|x - m_c\| = \min_i \{\|x - m_i\|\}, \forall i \in [1..u] \quad (1)$$

Where u is the number of map units and $\|x - m_i\|$ is a distance measure between x and m_i .

Adjacent units are connected by a neighbourhood relation which dictates the topology, or structure of the map. The SOM can be thought of as a net which is spread to the data input. The SOM training algorithm moves the weight vectors so that they span across the data input and so the map is organized.

In sequential learning algorithm, SOM is trained iteratively in time sequential manner. In each step, distances from the weight vectors of the current map and a randomly chosen input vector are calculated and BMU is found. After finding the BMU, his weight vector is updated so that the BMU is moved closer to

the current input vector. The topological neighbours of the BMU are also updated. This adaptation procedure stretches the BMU and its topological neighbours towards the sample vector. Kohonen update rule for weight vector of the unit i in the BMU neighbourhood is:

$$m_i(t+1) = m_i(t) + \alpha(t)h_{ci}(t)[x(t) - m_i(t)], \forall i \in [1..u] \quad (2)$$

Where $x(t)$ is the input vector randomly drawn from the input data set at time t , $h_{ci}(t)$ the neighbourhood kernel around the winner unit c and $\alpha(t)$ the learning rate at time t . The neighbourhood kernel is a non-increasing function of time and of the distance of unit i from the winner unit c . It defines the region of influence that the input sample has on the SOM. After the models have converged to their stationary states, the map units can be labelled by inputting the entries again and assigning the labels to the winner units. Some unit in the map there upon remains unlabeled.

3. Heuristic hierarchical and incremental models based on the SOM

The self-organizing map as introduced by Kohonen, has become a standard tool for the exploratory analysis of such data and has been extensively used for visualization purposes. A central parameter affecting the resolution of the SOM is the area of its map size. With a linearly increasing map area, the number of nodes in a SOM increase quadratically. Therefore, the training of large maps can be computationally quite expensive. Several approaches have been suggested to overcome this problem. Hierarchical models can provide more information from a data set. SOM has been developed in several ways in order to set it within hierarchical frameworks, which are common place as part of more standard statistical clustering procedures [25].

Koikkalainen and Oja [13] have proposed the tree-structured self-organizing map (TS-SOM), which consists of a fixed number of SOMs arranged in a pyramidal structure. The training of the pyramid is computed level wise where the best match search is performed as a tree search reducing the complexity to $O(\log N)$. The PicSOM [14], [15] image retrieval system is a framework for research on methods for content-based image retrieval. Instead of the standard SOM version, PicSOM uses a special form of the algorithm, the tree structured self-organizing map. The hierarchical TS-SOM structure is useful for two purposes. First, it reduces the complexity of training large SOMs by exploiting the hierarchy in finding the best matching unit BMU for an input vector. Second,

the hierarchical representation of the image database produced by a TS-SOM can be utilized in browsing the images in the database. In this system M. Koskela, J. Laaksonen, and E. Oja have used an image database containing 59 995 images from the Corel Gallery 1 000 000 product. The hierarchical SOM (HSOM) model usually refers to a tree of maps. The root of which acts as a preprocessor for subsequent layers. As the hierarchy is traversed upwards, the information becomes more and more abstract. Hierarchical self-organizing networks were first proposed by Luttrell [16]. He pointed out that although the addition of extra layers might yield a higher distortion in data reconstruction, it might also effectively reduce the complexity of the task. A further advantage is that different kinds of representations would be available from different levels of the hierarchy. A multilayer HSOM for clustering was introduced by Lampinen and Oja [17]. In the HSOM, the BMU of an input vector x is sought from the first-layer map and its index is given as input to the second-layer map. If more than one data vector concurs within the same neuron of the first layer map, the whole data histogram can be given to the second layer instead of a single index. This approach has been applied to document database management [2]. A Growing Hierarchical SOM has been proposed by Rauber and al. [12]. Their approach combines individually growing SOMs with a hierarchical architecture and has successfully been applied to the organization of document collections and music repositories. Pakkanen et al. [18] have described the evolving tree, which is constructed as a freely growing network utilizing the shortest path between two nodes in a tree as the neighborhood function for the self-organizing process. All of these approaches achieve a favorable computational complexity. However, the visualization of the learned hierarchies remains a demanding task. Either a map metaphor is not applicable, or the transition between maps within or across the hierarchies introduces discontinuities making it hard to visualize and maintain the surrounding context. Lately, an enhanced self-organizing incremental neural network (ESOINN) is proposed by Shen furao and all [26] to accomplish online unsupervised learning tasks. It improves the self-organizing incremental neural network (SOINN). An incremental network for on-line unsupervised classification and topology learning. Neural Networks, in the following respects: it adopts a single-layer network to take the place of the two-layer network structure of SOINN; it separates clusters with high-density overlap; it uses fewer parameters than SOINN; and it is more stable

than SOINN. Another variant based on the SOINN is proposed by Okada and all [27], an extension to SOINN to handle dynamic sequence patterns of variable length. They used a hidden markov model (HMM), as a pre-processor for SOINN, to map the variable-length patterns into fixed-length patterns. HMM contributes to robust feature extraction from sequence patterns, enabling similar statistical features to be extracted from sequence patterns of the same category.

4. Basic growing hierarchical self-organizing model

A growing hierarchical SOM has been proposed by dittenbach and al. [8], [10], [11]. Their approach combines individually growing SOMs with a hierarchical architecture. The GHSOM grows in two dimensions: in width (by increasing the size of each SOM) and in depth (by increasing the number of layers) [18], [19].

The GHSOM enhances the capabilities of the basic SOM in two ways. The first is to use an incrementally growing version of the SOM, which does not require the user to directly specify the size of the map beforehand; the second enhancement is the ability to adapt to hierarchical structures in the data. Prior to the training process a “map” in layer 0 consisting of only one unit is created. This unit’s weight vector is initialized as the mean of all input vectors and its mean quantization error (MQE) is computed. The MQE of unit i is computed as

$$MQE_i = \frac{1}{|U_i|} \sum_{k \in U_i} \|x_k - m_i\|, \quad U_i = \{k / c_k = i\} \quad (3)$$

Beneath the layer 0 map a new SOM is created with a size of initially 2×2 units. The intention is to increase the map size until all data items are represented well. A mean of all MQE_i is obtained as $\langle MQE \rangle$. The $\langle MQE \rangle$ is then compared to the MQE in the layer above, $\langle MQE \rangle_{above}$. If the following, inequality is fulfilled a new row or column of map units are inserted in the SOM,

$$MQE > \tau_1 \cdot \langle MQE \rangle_{above} \quad (4)$$

where τ_1 (parameter controlling the actual growth process of the GHSOM) is a user defined parameter. Once the decision is made to insert new units the remaining question is where to do so. In the GHSOM

array, the unit i with the largest MQE_i is defined as the error unit. Then the most dissimilar adjacent neighbor, i.e., the unit with the largest distance in respect to the model vector, is selected and a new row or column is inserted between these. If the inequality (4) is not satisfied, the next decision to be made is if some units should be expanded on the next hierarchical level or not. If the data mapped onto one single unit i still has a larger variation, i.e.

$$MQE_i > \tau_2 \langle MQE \rangle_{above} \quad (5)$$

where τ_2 (parameter controlling the minimum granularity of data representation) is a user defined parameter, then a new map will be added at a subsequent layer.

Generally, the values for τ_1 and τ_2 are chosen such that $1 > \tau_1 \gg \tau_2 > 0$, the GHSOM parameter, τ_1 and τ_2 are called “breadth” and “depth” controlling parameters, respectively. Generally, the smaller the parameter τ_1 , the larger the SOM arrays will be. The smaller the parameter τ_2 , the more layers the GHSOM will have in the hierarchy.

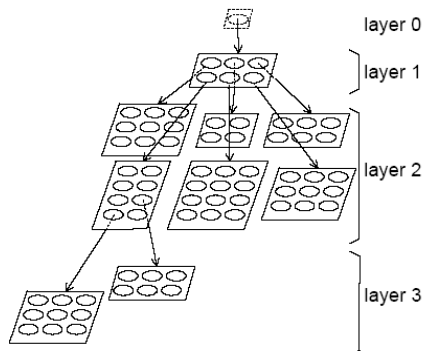

Figure 1. Growing hierarchical self-organizing map (GHSOM)

5. The growing hierarchical adaptive self-organizing map: GHAdSOM

In the growing hierarchical adaptive self-organizing map named “GHAdSOM” [23], each adaptive neuron i of each adaptive SOM of the hierarchy have its own neighborhood width parameter σ_i associated with it. When training of the GHAdSOM is started, the parameter σ_i is set to half the diameter of the lattice for all i . During training, sample vectors are presented to the GHAdSOM just like to the basic GHSOM, and weights are adjusted according to the familiar update rule, with decreasing learning rate. However, the width of neighborhood is determined by the σ_i value of the best matching unit.

The parameter σ_i is determined by the local topographic errors. If for a sample vector x the two

nearest weight vectors are w_j and w_k , and the corresponding best matching units n_j and n_k are not adjacent, there is local topographic error. Then, for units n_i that are near the two BMUs, a new value for the neighborhood radius σ_i is calculated [24]:

$$\sigma_i = \begin{cases} \|n_j - n_k\| & \text{if } \max \{ \|n_i - n_j\|, \|n_i - n_k\| \} \leq \|n_j - n_k\| \\ \|n_j - n_k\|^{-s} & \text{if } s = \min \{ \|n_i - n_j\|, \|n_i - n_k\| \} \leq \|n_j - n_k\| \\ 1 & \text{otherwise} \end{cases} \quad (6)$$

Thus, for units between the two BMUs, the new σ_i is equal to the distance on the map between the BMUs; outside that area, the σ_i decreases linearly to one.

6. Hierarchical GHAdSOM

The purpose of the proposed system is to create autonomous systems that can learn independently and cooperate to provide a better decision in classifying samples of entries. The hierarchical GHAdSOM reduces the complexity of the classification task and each layer provides its specific corresponding information for an input sample. At the first level of the hierarchy, we retrain the specific information of the macro-class label (Affricates, Stops, Nasals, Semivowels, Fricatives, Vowels, Others) (fig 2) of the input sample. At the second level of the hierarchy, we retrain the specific information of the phoneme label in its macro-class (if the macro-class is vowel, the phoneme label can be : /iy/, /ih/, /eh/, /ey/, /ae/, /aa/, /aw/, /ay/, /ah/, /ao/, /oy/, /ow/, /uh/, /uw/, /ux/, /er/, /ax/, /ix/, /axr/, /axh/) of the input sample (fig 3).

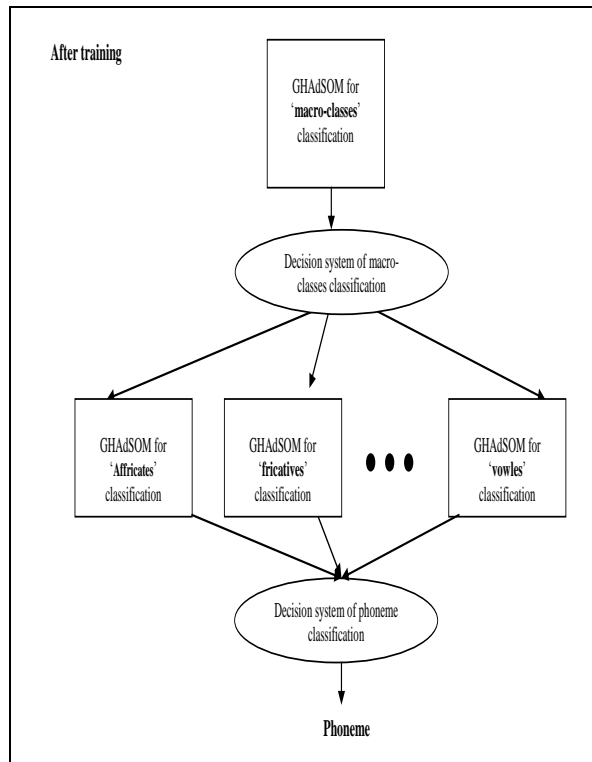

Figure5. Schema of hierarchical GHAdSOM model

For the proposed GHSOM variant, during learning process, we save information describing an input vector, when a sample input vector is attributed to a BMU neuron, she saves its corresponding vector, its label and updates its frequency activation. By this way, each neuron of each map of the hierarchy is characterized by:

- A general centroid vector (GCV): determined by means of Kohonen update rule (1).
- Information relating to each phoneme class attributed to a neuron :
 - Mean vector (MV) of the phoneme class.
 - Label of the phoneme class.
 - Frequency activation of the phoneme class.

7. Experimental results

7.1 Representation of speech data

TIMIT corpus was used to evaluate the proposed GHSOM variants in continuous speech and speaker independent context. TIMIT database contains a total

of 6300 sentences, 10 sentences spoken by each of 630 speakers from 8 major dialect regions.

Speech utterance was sampled at a sampling rate of 16 KHz using 16 bits quantization. Speech frames are filtered by a first order filter whose transfer function is:

$$H(z) = 1 - a.z^{-1}, \quad 0.9 \leq a \leq 1.0 \quad (7)$$

Where z^{-1} is the delay operator. In our experiments, a is chosen to be 0.95. After the pre-emphasis, speech data consists of a large amount of samples that present the original utterance. Windowing is introduced to effectively process these samples. This is done by regrouping speech data into several frames. In our system, a 256 sample window that could capture 16 ms of speech information is used. To prevent information lost during the process, an overlapping factor of 50% is introduced between adjacent frames. After regrouping, each individual frame needs to be further pre-processed to minimize signal discontinuities at the beginning and at the end of each frame. A commonly used technique is to multiply the signal data with the hamming function. The earlier has smoothing effects at edges of the filter. This function can be described by the following equation:

$$h(n) = 0.54 - 0.46 * \cos\left(\frac{2\pi n}{N-1}\right) \quad 0 \leq n \leq N, \quad (8)$$

$$N > 1$$

Where n is the sample number and N is the total number of samples per window. In our case, N is 256. Thereafter, mel frequency cepstral analysis was applied to extract the 12 mel cepstrum coefficients. The mel scale is an equi-pitch scale describing the subjective and perceptual response to frequency of human listener. The implemented neural networks are trained by presenting them with 12 input values from three frames selected at the middle of each phoneme. Table1 shows the list of phonemes of each macro-class of TIMIT database.

Table 1. List of phonemes of each macro-class of TIMIT database.

Macro-class	phonemes
Affricates	/jh/, /ch/
Stops	/b/, /d/, /g/, /p/, /t/, /k/, /dx/, /q/, /bcl/, /dcl/, /gcl/, /pcl/, /tcl/, /kcl/
Nasales	/m/, /n/, /ng/, /em/, /en/, /eng/, /nx/
Semivowels	/l/, /r/, /w/, /y/, /hh/, /hv/, /el/
Fricatives	/s/, /sh/, /z/, /zh/, /f/, /th/, /v/, /dh/
Vowels	/iy/, /ih/, /eh/, /ey/, /ae/, /aa/, /aw/, /ay/, /ah/, /ao/, /oy/, /ow/, /uh/, /uw/, /ux/, /er/, /ax/, /ix/, /axr/, /axh/
Others	/pau/, /epi/, /h#/

7.2 Classification process

Classification is performed at frame level and performance is evaluated by comparing each classified frame with reference one. In the case of the basic GHSOM, a classification decision is operated as follows: for a given sample input vector, we search for its BMU. In the case of the proposed GHSOM variants, a classification decision is operated in two steps. At a first step, for a test sample vector presented to a GHSOM variant we search for the BMU among all general centroid prototype vectors of a map. Thereafter, inside selected BMU unit, we search for the best prototype vector of different classes, in terms of minimal Euclidean distance. This process is repeated layer by layer using knowledge about the BMU of the frozen layer (l -1) in the search of the BMU on the next layer (l). For example, the search of the BMU in the layer 2 is restricted into the map (c) connected to BMU of the layer 1. And when we are in the last level of the hierarchy, we look for the label of the last BMU.

In the hierarchical GHAdSOM model a classification decision is made at two levels:

- At the level of the hierarchy, a GHAdSOM variant of the first layer determines the membership of a window of an input sample to a macro-class.
- At the lower level of the hierarchy, a variant GHAdSOM decide membership of a window of an input sample to a phoneme class.

7.3 Results and discussions

We have implemented the GHSOM model based on sequential learning and the proposed GHSOM variants (hierarchical GHAdSOM), to be able to compare the efficiency and robustness of the proposed GHSOM modification described by multiple prototype vectors. After training the basic GHSOM model, neural units are labelled according to which phoneme sound they respond to. This was achieved by representing the map with speech frames from stationary phoneme samples. Neural units which consistently achieved a best match with a particular phoneme sample were labelled with that phoneme symbol. For the proposed GHSOM variants, during learning process, we save information describing an input vector.

Table 2 shows a comparison of different classification rates of the 7 macro class of TIMIT database obtained by using respectively, GHSOM based on a sequential learning (Basic GHSOM) and hierarchical GHAdSOM.

In the two experiments parameter r_1 which controls the actual growth process of these models is equal to 0.7 and r_2 parameter controlling the minimum granularity of data representation is equal to 0,02. All maps are trained for 500 iterations.

Table 2. Classification rates of the 7macro-class of TIMIT database (training set and test set).

	Basic GHSOM		Hierarchical GHAdSOM	
	training	test	training	test
Fricatives	60.22	42.13	90.40	78.42
Affricates	65.13	59.77	87.45	68.94
Vowels	44.89	31.18	89.99	61.13
Nasales	53.12	47.21	92.88	79.90
Semivowels	59.47	47.90	85.88	79.30
Stops	39.50	25.01	86.99	60.33
Others	42.13	52.30	86.00	86.58
Mean classification rates	52.06	43.64	88.51	73.51

We should note also that the proposed learning process based on multiple prototype vectors provides more accurate classification rates than the basic GHSOM. This is due to the partition of a neuron in different regions proportional to frequency activation of a class. According to table 2, hierarchical GHAdSOM provides the best classification accuracy in training set and in test set, this prove robustness of this variant.

8. Conclusion

In this paper, we have proposed a new variant of the hierarchical neural network algorithm in the unsupervised learning category, and we are interested in phoneme classification by means of a new GHSOM variant named GHAdSOM a hierarchical model based on a locally adapting neighborhood radii where each adaptive neuron of each adaptive map level is characterized by a general centroid prototype vector and a mean prototype vector for each phoneme class. The case study of such learning algorithms is phoneme classification in continuous speech and speaker independent. The second proposed variant is the hierarchical GHAdSOM model which represents a multi-layer extension of GHAdSOM model. The hierarchical GHAdSOM model proposed is composed of two layers. The first layer is composed of a single variant GHAdSOM ensuring the classification of the seven macro-classes. The second layer is composed of seven models GHAdSOM ensuring the classification of phonemes of a given macro-class. We demonstrate that the proposed GHSOM variants provide more accurate phoneme classification rates in comparison with the basic GHSOM model. These are due to intra unit and inter unit prototype vectors. In fact, in the proposed GHSOM variants, each unit of a each map is described by a general centroid prototype vector and a mean prototype vector for each phoneme class. By this way, we show that the formation of a topologically ordered mapping from the signal space onto the detailed phonotopic map provides interesting and important results. The hierarchical GHAdSOM provides best classification rates in comparison with the basic GHSOM variant.

The advantage of such a hierarchical model is the construction of several elementary GHAdSOM as isolated modules, which can learn independently and cooperate. Moreover, rapid search of the winner (BMU), the speed of convergence, better generalization ability, a greater capacity for abstraction and reduced computational cost.

As a future work, we propose to implement a cooperative system of GHSOM for phoneme

recognition. The system of GHSOM is based on the association of different GHSOM variants of supervised and unsupervised learning algorithms. The objective of such system is to create a cooperative system based on different competitive learning algorithms. We suggest also to hybridize GHSOM and genetic algorithm to fine tune GHSOM parameters.

References

- [1] T. Kohonen, "Self-organizing map", third edition, Springer, 2001.
- [2] T. Kohonen, S. Kaski, K. Lagus, T. Honkela, "Very large two level SOM for the browsing of newsgroups", in proceedings of the International Conference on Neural Networks (ICANN), pp 269-274, 1996.
- [3] J.P. Haton, "Tutorial and research workshop on robust speech recognition for unknown communication channels", Pont-à-Mousson, Proceedings of the ESCA-NATO, France 1997.
- [4] S. Nakagawa, K. Shikano, Y. Tohkura, "Speech hearing and neural network models", Amsterdam, Oxford, Tokyo, Washington, DC, (IOS Press), 1995.
- [5] D. Alahakoon, S.K. Halgamuge, B. Srinivasan, "Dynamic self-organizing maps with controlled growth for knowledge discovery", IEEE Transactions Neural Networks, vol 11, no 3, pp 601-614, 2000.
- [6] J. Blackmore, R. Miikkulainen, "Incremental grid growing: Encoding high-dimensional structure into a two-dimensional feature map", in proceedings of the International Conference on Neural Networks, San Francisco, (ICANN), pp 450-455, 1993.
- [7] B. Fritzke, "Growing grid – a self-organizing network with constant neighborhood range and adaptation strength", (Neural Processing Letters), Vol. 2, pp 9-13, 1995.
- [8] M. Dittenbach, D. Merkl, A. Rauber, "The growing hierarchical self-organizing map", in proceedings of the International Joint Conference on Neural Networks (IJCNN), Vol. 6, pp 15-19, 2000.
- [9] M. Dittenbach, "The growing hierarchical self-organizing map: Uncovering hierarchical structure in data", Master's thesis, Vienna University of Technology, December 2000.
- [10] M. Dittenbach, A. Rauber, D. Merkl, "Uncovering the hierarchical structure in data using the growing Hierarchical self-organizing map", (Neurocomputing), Vol48, no 1-4, pp 199-216, 2002.
- [11] M. Dittenbach, A. Rauber, D. Merkl, "Using

growing hierarchical self-organizing maps for document Classification”, European Symposium on Artificial Neural Networks, (ESANN), pp 7-12, 2000.

[12] M. Dittenbach, A. Rauber and Polzlbauer, “Investigation of alternative strategies and quality measures for controlling the growth process of the growing hierarchical self-organizing map”, proceeding of the International Joint Conference on Neural Networks, (IJCNN), pp 2954-2959, 2005.

[13] P. Koikkalainen, E. Oja, “Self-organizing hierarchical feature maps”, in proceedings of the International Joint Conference on Neural Networks (IJCNN), 1990.

[14] J.T Laaksonen, J.M Koskela, S.P.Laakso, E. Oja, “PicSOM –Content-based image retrieval with self-organizing maps”, Pattern Recognition Letters, pp 1199-1207, 2000.

[15] J. Laaksonen, M. Koskela, S. Laakso, E. Oja, “Self-organizing maps as a relevance feedback technique in content-based image retrieval”, Pattern Analysis & Applications, pp 140–152, 2001.

[16] S.P Luttrell, “Hierarchical self-organizing networks”, in Proceedings of the International Conference on Neural Networks, (ICANN), pp 2-6, 1989.

[17] J. Lampinen, E. Oja, 1992, “Clustering properties of hierarchical self-organizing maps”, Journal of Mathematical Imaging and Vision, vol 2, pp 261-272, 1992.

[18] J. Pakkanen, J. Iivarinen, E. Oja, 2004, “The evolving tree – a novel self-organizing network for data analysis”, Neural Processing Letters, vol. 20, no. 3, pp 199–211, 2004.

[19] S. Tangsripairoj, M.H. Samadzadeh, “Organizing and visualizing software repositories using the growing hierarchical self-organizing map”, Journal of Information Science and Engineering, vol 22, pp 283-295, 2006.

[20] E. Pampalk, Widmer, A. Chan, “A new approach to hierarchical clustering and structuring of data with self-organizing maps”, Intelligent Data Analysis Journal, vol 8, no 2, pp 131-149, 2004.

[21] N. Arous, “Speech clustering by means of self-organizing maps”, Tunisian-German Conference on Smart Systems and Devices, Hammamet-Tunisia, pp 27-30, 2001.

[22] N. Arous, N. Ellouze, “Cooperative supervised and unsupervised learning algorithm for phoneme recognition in continuous speech and speaker-

independent” context, Elsevier Science, (Neurocomputing), Special Issue on Neural Pattern Recognition, vol 51, pp 225 – 235, 2003.

[23] C. Jlassi, N. Arous, N. Ellouze, “Comparative Study of Growing Hierarchical SOM Variants Case Study: Phoneme Recognition”, International Review On Computers and Software, vol 3, no 2, pp 120-128.

[24] K. Kiviluoto, “Topology preservation in self-organizing maps”, Proceeding of International Conference on Neural Networks (ICNN), pp 294-299, 1996.

[25] C. Hung, S. Wermter, “A dynamic adaptive self-organising hybrid model for text clustering”, in Proceedings of The 3rd International Conference on Data Mining, Melbourne, FL: (IEEE Computer Society), pp 75–82, 2003.

[26] F. Shen, T. Ogura, O. Hasegawa, “An enhanced self-organizing incremental neural network for online unsupervised learning”, Neural networks journal, (Elsevier Science), vol 20, no 8, pp 893-903, 2007.

[27] S. Okada, T. Nishida, “Incremental clustering of gesture patterns based on a self organizing incremental neural network”, International Joint Conference on Neural Network, (IJCNN), pp 2316-2322, 2009.

Author Biographies

^{1,2,3} Ecole Nationale d'ingénieurs de Tunis, unité de recherche signal, image, reconnaissance de forme, BP-37 Campus Universitaire 1002 Tunis, Tunisia



Chiraz Jlassi received a university diploma in computer science in 1999 from (FST Tunisia), the MS degree in electrical engineering (signal processing) from Ecole Nationale d'ingénieurs de Tunis (ENIT), Tunisia, the Ph. D. degree in electrical engineering (signal processing) from ENIT.

She is currently a computer science assistant in the informatics department at FSHST, Tunisia. Her research interests include speech recognition, hierarchical neural networks and evolutionary neural networks .



Najet Arous received computer science engineering degree from Ecole Nationale des Sciences d'Informatique (ENSI), Tunis, Tunisia, the MS degree in electrical engineering (signal processing) from Ecole Nationale d'ingénieurs de Tunis (ENIT), Tunisia, the Ph. D. degree in electrical

engineering (signal processing) from ENIT. She is currently a COMPUTER SCIENCE ASSISTANT in the computer science department at ISI (Institut Supérieur d'Informatique), Tunisia. Her research interests include scheduling optimization, pattern recognition, speech recognition and evolutionary neural networks.



Second N. Ellouze received a Ph.D. degree in 1977 from l'Institut National Polytechnique at Paul Sabatier University (Toulouse-France), and Electronic Engineer Diploma from ENSEEIHT in 1968 at the same University.

In 1978, Dr. Ellouze joined the Department of Electrical Engineering at the National School of Engineer of Tunis (ENIT-Tunisia), as ASSISTANT PROFESSOR in statistic, electronic, signal processing and computer architecture. In 1990, he became Professor in signal processing; digital signal processing and stochastic process. He has also served as director of electrical department at ENIT from 1978 to 1983. General manager and President of the Research Institute on Informatics and Telecommunication IRSIT from 1987-1990, and President of the Institut in 1990-1994. He is now Director of Signal Processing Research Laboratory LSTS at ENIT, and is in charge of Control and Signal Processing Master degree at ENIT.

Pr Ellouze is IEEE fellow since 1987, he directed multiple Masters and Thesis and published over 200 scientific papers both in journals and proceedings. He is chief editor of the scientific journal *Annales Maghrébines de l'Ingénieur*. His research interest include neural networks and fuzzy classification, pattern recognition, signal processing and image processing applied in biomedical, multimedia, and man machine communication.

Assessment of Mobile Agent Frameworks Based on Security

Dr.Shuchita Upadhyaya¹ Pooja²

¹ Department of Computer Science & Applications
Kurukshetra University, Kurukshetra

² Department of Computer Science & Applications
Kurukshetra University, Kurukshetra

shuchita_bhasin@yahoo.com, er.pooja.arora@gmail.com

Abstract: The main aim of mobile agent frameworks is to provide an infrastructure that can support distributed computing applications involving the movement of components in different execution environments. For distributed computing, the design and implementation of mechanisms to relocate computations is required that requires a careful assessment of security issues. Without considering these issues properly, mobile agent technology cannot be used to implement real-life applications.

Keywords: Mobile Agent, Mobile Agent Frameworks, Security, Authorization, Aplets, ARA.

1. Introduction

During the last decade, various mobile agent middleware systems – also called mobile agent frameworks or mobile agent platforms – have been developed to support (mobile) multi-agent applications [1] [2]. Mobile agent applications depend on Mobile Agent Frameworks for mobility, agent life-cycle management, communication, migration and security.

Java is used for the implementation of most agent frameworks because Java provides portability and some security assurance. Very few systems support agents written in other programming languages than Java [3].

In this paper, we compare the features of existing mobile agent frameworks based on security primitives. Section 2 represents the security primitives in Mobile Agent Frameworks. In Section 3, we will discuss security primitives in some popular mobile agent frameworks particularly. Section 4 represents the tabular Assessment of various Mobile Agent Frameworks against various security primitives. Section 5 concludes this paper.

2. Security Primitives

While agents definitely offer many advantages, the design of a secure mobile agent system has been hindered by the lack in ability of the current systems to provide sufficient protect, in particular, to the mobile agents from being tampered by a malicious host. From the various researches performed by researchers [4] [5], many mobile agent security issues can be identified those can be translated into a set of security criteria that a mobile agent system needs to fulfill. This can be summarized as follows:

Confidentiality of the framework: The mobile agent framework must have mechanisms for secure communication and secure transfer of agent components as it migrates from host to host in an insecure network.

Integrity of the framework: There must be mechanisms in place to identify tampering with the agent framework.

Authentication of the various entities of the framework: The entities such as the agents and hosts participating in the mobile agent applications must be clearly identifiable.

Authorization and access control: The agent framework must have some mechanisms in place to protect their resources by specifying their access control policies and be in a position to enforce them.

The following list presents the factors that can be used with respect to agent security to be used in evaluating the mobile agent frameworks.

- 1) Mechanisms supported for agent confidentiality (Cryptographic techniques).
- 2) Mechanisms to support agent integrity. (Cryptographic techniques).
- 3) Mechanisms for authentication of the agent's owner. (Digital signatures):
- 4) Mechanisms used for authorization and access control (access list/ policies):

3. Security primitives in Different Mobile Agent Systems

3.1 D'Agents

D'Agents (also known as Agent Tcl) was developed at Dartmouth Collage to address the weaknesses of then existing mobile agent frameworks, such as inadequate security mechanisms, difficult or nonexistent communication facilities and inadequate migration facilities. It is developed in UNIX and can be written in multiple languages such as Tool command language (Tcl), Java or Schema.

3.1.1 Security

The design of D'Agents, mainly offers protection for the host machine. Each D'Agents server distinguishes between two kinds of agents: owned and autonomous. An owned agent is an agent whose owner could be authenticated and is on the server's list of authorized

users whereas an autonomous agent is one that cannot be authenticated or is not on the server's list of authorized users. Based on this distinction an agent is assigned access to the resources [6]. Agent authorization functionality in this mobile agent system is distributed between the respective language interpreters and language-independent system components (e.g. resource management agent). The interpreter uses its native language mechanisms to manage and enforce access rights that are implemented as lists, mapping the requested resource types to available quantities. The interpreter in consultation with resource management agents obtains the access rights for a specific agent. The resource manager agents are a standard part of D'Agents system and are associated with specific resources through a list of access rights for each agent.

The D'Agents servers make use of public key cryptography to authenticate the identities of incoming agent's owners as each machine and owner has its own public-private key pair. Pretty Good Privacy (PGP) is used for digitally signatures and encryption. An agent may choose to use encryption and signatures when it migrates or sends a message to another agent. If interception is of no concern then encryption may be turned off. If an agent is not concerned with tampering during migration and can accomplish its task as an autonomous agent, it turns off signatures. Similar decisions may be taken when sending messages. Turning off either signature or encryption improves performance due to the slowness of public-key cryptography [7].

Like many other MAS, such as Mole and Voyager, D'Agents do not as yet have any means of protecting agents from attacks by malicious hosts. By executing each agent in its own interpreter, a mobile agent can be protected from attack by another agent on the same host.

3.2 TACOMA (Tromsø and Cornel Moving Agents)

TACOMA project focuses on operating systems support for agents and the way agents can be used to solve problems traditionally addressed by other distributed computing paradigms, e.g. the client/server model. In TACOMA the agents are modeled as a migrating process that moves through the network to satisfy client requests [8].

3.2.1 Security

TACOMA uses operating system features to encapsulate agents and provides additional security using language specific features. TACOMA also provides access control on a per agent basis. This access control is based upon the authentication of the principal whom the agent is working for (the owner of the agent). The access control in the form of vector of access right to the resources is enforced by the firewalls in conjunction with virtual machine service agents. The virtual machine service agents ensure that the agents that they execute only interact with the underlying operating system and remainder of the site's environment through primitives they provide. TACOMA allows agents to be accompanied by digital certificates stored in their

xCODE-SIG folder. These certificates are interpreted by service agents as defining accesses permitted by the signed code [8].

In addition to providing protection for the host, TACOMA also caters, in a limited way, for agent integrity – computations must be protected from faulty or malicious hosts. This is achieved using replication and voting [9].

3.3 WASP (Web Agent-based Service providing)

The WASP project is an initiative of Darmstadt University of Technology with the goal of providing services on web data using mobile agents to implement these services [10]. The WASP system is built upon the idea of using agent technology in conjunction with the WWW- by extending (and not just using) the WWW to provide a ubiquitous mobile agent framework. WASP agents rely not only on Java's distributed computing concepts but integrate agent environments into WWW servers with the help of server extension modules to achieve its functionalities.

3.3.1 Security

Like most MAS, WASP also provides the basic security mechanisms to protect a host from malicious agents. Data security is provided by means of protection domain called realms. A realm consists of a set of data, specified by local URLs, to which access is restricted. For every realm there is an owner (human or agent) who can define rights for the realm (read, write, execute, etc.) Based on the identities of the agent / user, access to the realm is assigned [11].

For the purpose of authentication and authorization of agents, WASP makes use of Java Card – a smart card containing Java byte code interpreter. The Java Card in conjunction with SAE is also used as trusted computing base for mobile agents. All such cards have their own private key that is used for decryption of agents and used as a means for authentication of parties involved. Unauthorized access to agent's data during transit is protected by the use of encryption.

3.4 AGLETS

Aglets, developed by IBM, is one of the more popular frameworks developed in Java on Windows platform. The mobile agents are referred to as 'aglets' and migrate between agent servers known as aglet context. The aglet context is the execution environment in which aglets operate. It provides an interface to the underlying operating system through which the aglets are able to access the core facilities and gain reference to other aglets.

3.4.1 Security

Aglets are Java objects and have access to potentially all Java class files on the host; they also rely on the security of the Java interpreter for their proper execution. Thus, aglet security and Java security go hand in hand. The Aglets model features the agent, the host (context), and the host domain, each split into three

independent principals as the entity itself, the entity's owner and its manufacturer.

The exception being the host domain as it does not have its manufacturer (in total eight principals). To allow fine-grained control, a security policy consists of a set of named privileges and a mapping from the principals to the privileges is used [12].

For aglets transportation, a secure channel is established. The sending context protects the integrity of aglet data by computing a secure hash value that allows the receiving context to perform after-the-fact detection of tampering. Unauthorized access to aglets data during transit is protected by the use of encryption [12]. Aglets, like Ara implements authentication base on Secure Socket Layer (SSL) protocol. As in most other MAS, Aglets too fall short when considering host attack on its agents [13].

3.5 ARA (Agent for Remote Action)

This framework was developed at the University of Kaiserslautern, Ara is a Multilanguage Mobile Agent framework written in C, C++, Tcl or Java, for portable and secure execution of mobile agents in heterogeneous environment. Ara's main design aims are to provide full mobile agent functionality while retaining as much as possible of established programming models and languages- mobility should be integrates as seamlessly as possible with existing programming concepts and avoid remote communication altogether [14].

3.5.1 Security

Security in Ara, like in D'Agents, is implemented by executing agents within an interpreter, which controls their resource accesses, and enforces authorization policy expressed in the form of allowances; agents and hosts may be authenticated, agent transfers may be encrypted, and any resource consumption is accounted. In addition to establishing a domain of logically related services under a common security policy, a place's central function is to decide on the condition of admission, if at all, of an agent applying to enter that place. These conditions are expressed in the form of an allowance, a vector of access rights to the resources, approved for the agent for the duration of its stay at that place. It is the function of the Ara core to ensure that an agent never oversteps its allowance [15].

The Ara security model builds in authentication of agents and hosts by using digital signatures and public key certificates. Ara supports authentication base on Secure Socket Layer (SSL) protocol [15]. SSL is a connection-oriented, bi-directional point-to-point data transfer protocol offering authentication of both end points as well as encryption and authentication of the data transferred, offering various cipher suites and certificates. Like most other MAS, Ara too has as yet not implemented any mechanism for agent protection from malicious hosts.

4. Assessment of Mobile Agent Frameworks

against Security factors

Mobile Agent Frameworks can be evaluated based on various factors. Following table shows the evaluation of these frameworks based on these factors:

4.1 Table

Table 1. Assessment of Mobile Agent Frameworks against Security factors

	D'Agents	Tacoma	WASP	Aglets	ARA
Agent Confidentiality	Encryption using PGP	Encryption	Using Hardware(Java Card)	Encryption using SSL	Encryption using SSL
Agent Integrity	Digital Signature using PGP	Digital Signature	Using Hardware(Java Card)	Digital Signature using SSL	Digital Signature using SSL
Authentication of Agent's owner	Digital Signature using PGP	Digital Signature	Using Hardware(Java Card)	Digital Signature using SSL	Digital Signature using SSL
Authorization & Access control	Resource management via access right list	Virtual machine service agent via access right list	SAE via Access right list	Context via policies	Places via allowances

5. Conclusion

This paper presented some initial results of a research effort aimed at the analysis of the security issues in mobile agent systems. The long term goal of this study is to understand the security issues in Mobile Agent Systems and to provide a reference model that can help in abstracting security mechanisms and in defining attack classes in a way that is independent of a particular technology. Future work will focus on completing the security analysis of the additional systems and in developing a reference model.

References

- [1] Baumann, J., Hohl, F., Strasser, M. and Rothermel, K. *Mole – Concepts of a Mobile Agent System*, Technical Report, August, Universität Stuttgart.,1997.
- [2] Tripathi, A.R., Ahmed, T. and Karnik, N.M. 'Experiences and future challenges in mobile agent programming', *Microprocessor and Microsystems*, April, Vol. 25, No. 2, pp.121–129, 2001.
- [3] Gray, R.S., Kotz, D., Cybenko, G. and Rus, D. 'D'agents: security in a multiple-language, mobile-agent system', *Mobile Agents and Security*, pp.154–187, LNCS 1419, Springer-Verlag,1998.
- [4] JANSEN. Mobile Agents and Security, *Web Report*. Available at:<http://csrc.nist.gov/staff/Jensen/pp-agentsecurityfin.pdf>,1999.
- [5] BIERMANN, E., CLOETE, E.. Classification of Malicious Host Threats in Mobile Agent Computing, In *Proceedings of SAICSIT*, pp. 141-148, 2002..
- [6] GRAY, R S, CYBENKO, G., KOTZ, D., PETERSON, R.A., RUS, D. D'Agents: Applications and performance of a mobile agent system. *Software:*

Practice and Experience, Vol. 35, No. 6, pp. 534-573,2002.

[7] GRAY, R. S., KOTZ, D., CYBENKO, G., RUS, D.. D'Agents: Security in a multiple-language, mobile-agent system. In Giovanni Vigna Ed.,*Mobile Agents and Security*, LNCS, Vol. 1419, pp. 154-187, Springer-Verlag,1998.

[8] JOHANSEN, D., LAUVSET, K. J., RENESSE, R. V., SCHNEIDER, F. B.,SUDMANN, N. P., JACOBSEN, K. A TACOMA retrospective, *Software-Practice and Experience*, Vol. 32, No. 6, pp. 605-619.2002.

[9] JOHANSEN, D., LAUVSET, K. J., AND MARZULLO. K. An Extensible Software Architecture for Mobile Components, In *Proceedings of the 9th IEEE Conference and Workshops on Engineering of Computer-Based Systems*, pp. 231-237,Lund, Sweden.2002.

[10].FÜNFROCKEN, S. How to Integrate Mobile Agents into Web Servers, *In Proceedings of 6th IEEE Workshop in Enabling Technologies: Infrastructure for Collaborative Enterprises*, pp. 94-99, Boston, USA, 1997.

[11].FÜNFROCKEN, S. Transparent Migration of Java-based Mobile Agents (Capturing and Reestablishing the State of Java Programs), In: *Kurt Rothermel, Fritz Hohl (Eds.), Proceedings of Second International Workshop on Mobile Agents (MA'98)*, LNCS 1477, pp. 26-37, Springer- Verlag, Berlin, Germany,1998.

[12]. FISCHMEISTER, S., VIGNA G., KEMMERER, R. A. Evaluating the Security of Three Java-Based Mobile Agent Systems, In G. P. Picco (Ed.), LNCS 2240, pp.31-44, 2001.

[13]. GONG, L. Secure Java Class Loading. *IEEE Internet Computing*, Vol. 2, No. 6,pp. 56-61,1998.

[14].PEINE, H.. Application and Programming Experience with the Ara Mobile Agent System, *Software- Practice and Experience*. Vol. 32, No. 6, pp. 515-541,2002.

[15].PEINE, H. Security concepts and Implementations on the Ara Mobile Agent System, In *Proceedings of the seventh IEEE Workshop on Enabling Technologies: Infrastructure for the Collaborative Enterprises*,WETICE'98.California,USA.Available at <http://www.wagss.informatik.uni-kl.de/projekte/Ara/Doc/ara-security.ps.gz>,1998

Author Biographies



Dr. Shuchita Upadhyaya

Is an associate professor in the Department of Computer Science and applications in Kurukshetra University, Kurukshetra, India. She is Ph.D. in Computer Science and application. Her area of specialization is Computer Network. She has published more than 35 research papers in various national and International Journals. She is having 22 years of teaching and research experience.

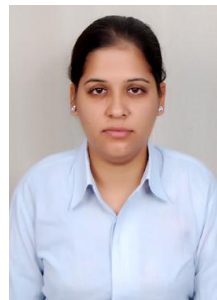

Pooja Is M.Tech. student in the Department of Computer Science and applications in Kurukshetra University, Kurukshetra, India. She is having three years of teaching experience.

Policy Levels Concerning Database Security

Khaleel Ahmad¹, Jayant Shekhar², Nitesh Kumar³, K.P. Yadav⁴

^{1,2,3}SVS University, Department of Computer Science and Information Technology

⁴ACME College of Engineering, GBT University

^{1,2,3,4}U.P., India

¹khaleelamna@yahoo.co.in, ²jayant_shekhar@hotmail.com, ³nitesh24kumar@gmail.com,
⁴karunesh732@gmail.com

Abstract: Security is one of the major concerns for any database system. Developing a good database and providing security control for the database has always been a big problem. Database security not only means the protection of the data but also authenticate the user what they need. It bound the database according to the user. This paper discusses the various security policies in databases. This approach is useful for the planning for the development of a secured database.

Keywords: Database Security, Database Security Policies, Security.

1. Introduction

Information is amongst the most important asset of an organization. Compromising with its security may lead to a major setback to the organization. With the advent of highly technological advances, it has become a rather simple task to intrude into the confidential information. So the security of database has become a major challenge for any organization [1] [3].

The main requirements of security of database are [4][8].

- 1) Confidentiality
- 2) Integrity
- 3) Availability

Other requirements that are not conventionally considered are:

- 1) Information Quality
- 2) Completeness

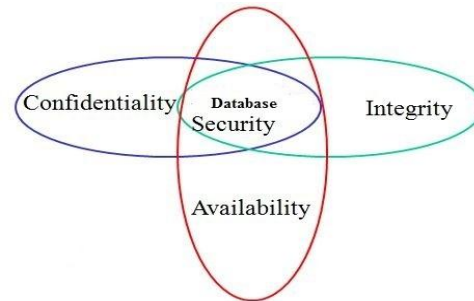

Figure 1

There are various database applications that require information security that cannot be modified, manipulated, deleted or tempered in any way, see figure 1. To achieve these requirements; there are various mechanisms that have been devised which caters to the requirements of security. These mechanisms put a check on the threats that can seriously affect the security of the database. In order to maintain the security of the information, some required policies must be adopted for secure database [8]. The remainder of the paper is organized as follows. In the section II gives and about the database policy layers and policy concerning security is given in the section III. Finally, section IV presents the conclusion and future work.

2. Database Security Layers

Each layer will check specified policies which are given in the table 1 against incoming data from outside or Internet. Every layer has some specified database security policies which authenticates and authorizes the sensitive data giving a greater security [5] [12].

DBA: The main act of a database administrator has to do with overseeing the accessing and authorization of database on a system designed for use by a number of users.

System administrator: It is a person employed to maintain and operate a computer system and network.

Security Officers: It creates and grants user-defined roles to users, other roles, or groups.

Developers: A database developer design and develop a database.

Employee: An employee uses the function of database and web application for business.

From the figure 2 you can easily understand how database can be accessed and checked.

3. Policies Concerning Securities

These are security policies which will work on each layer of database which ensures the principles of security i.e. accuracy, authentication and identification, availability, access control, confidentiality, integrity, exists there [7][8][12].

Following are the Database Security Policies along with the database security layers, see table 1.

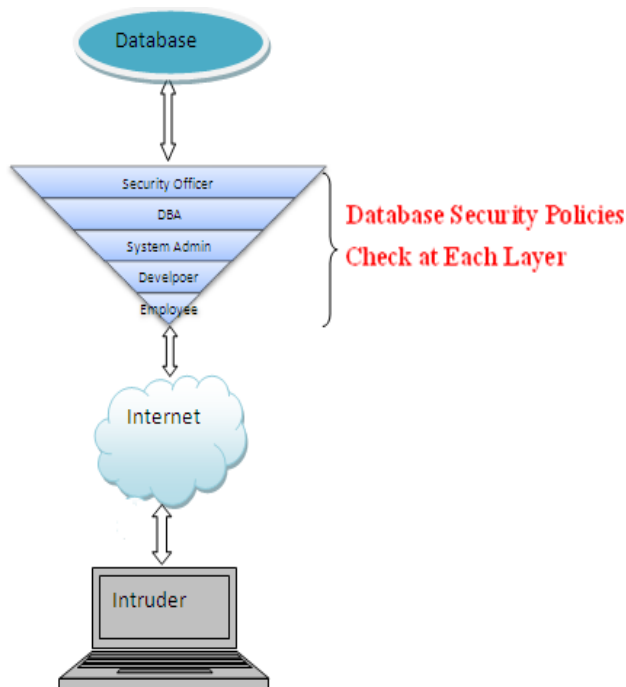

Figure 2. Policy Layers

TABLE 1 DATABASE SECURITY POLICIES

S. No.	Database Security Policies	Security officer	DBA	System Admin	Developer / Software Engineer	Employee
1.	Grant privilege only if the request is properly documented and approved and provide only necessary privilege to the user.	√				
2.	To protect passwords, credit card numbers, and other confidential and sensitive data, use encryption.	√		√	√	
3.	In order to ensure business continuity, establish a disaster recovery strategy for every database application in production. All the procedures should be documented that are followed from the moment a disaster is declared by the management to the	√			√	

	moment the database applications are recovered.					
4.	Secure measures to be employed to authenticated and authorized persons to access the operating system server and the database server.			√		
5.	For the purpose of implementing and monitoring all security policies and standards, establish a position in your organizational structure.	√	√			
6.	For any data or database modification establish a database management change process and approval mechanism. Also provide approval explanation and justification of the change by all the parties who have a stake in the database.		√			
7.	Include appropriate data sanitization routines in all application components and auxiliary services.					√
8.	Exception handling should always offer minimal information which may offer the detail to attacks to diagnose and refine hacking attempts.			√	√	√
9.	Create a new login/user specifically for each application and deny access to all objects that are unnecessary to be used by the application.			√		
10.	Avoid displaying detailed error message.					√
11.	Access to the production database via database links or linked servers, to be kept secure from database development and testing.		√			
12.	Remove all PUBLIC privileges where possible from the database.		√			
13.	Require authentication for all SQL Server accounts and ensure that passwords meet State standards		√		√	
14.	Allow well-defined set of safe values via regular expression (e.g. [A-Za-z0-9]).				√	
15.	Implement the design principle of least privilege on SQL servers. Run separate SQL Server services under separate accounts with the lowest possible privileges.		√		√	
16.	Never grant permissions to the PUBLIC database role.		√			
17.	To ensure the working of all the security measures and that they are all enabled, perform audits regularly and randomly.		√	√		
18.	Database assigned duties are not allowed.	√	√			
19.	Avoid information leakage of database connection string assessment.	√				
20.	To prevent intrusion from malicious code, install antivirus and antispymware programs, an e-mail spam blocker, and a network firewall.			√		
21.	All the database production guides, operations, procedures, and application manuals should be updated and current.		√			
22.	To secure and protect data integrity and confidentiality, implement good security design in your application.	√	√			
23.	For employees who need to access the database remotely, establish a secure VPN in tunnel mode.				√	

24.	All the security patches and service packs for the OS and database system to be applied and maintained up to date.			√		
25.	Change all the default database password.		√			
26.	To prevent easy access to data, change the default configuration of the database and operating system.	√		√		
27.	There must be one database user account for the application schema owner.		√			
28.	Limit user access. Use the principle of least privilege and ensure that the users created for the applications have the privileges needed and no more. All extra privileges, for example, PUBLIC ones, should not be available.			√		
29.	Password must be stored within the designed security module.	√	√			
30.	Keep a check on security violation of any degree, keeping the investigation on such violations discreet.	√		√		
31.	Publish security policies and standards, and establishing the same, thereby raising awareness about these documents at all levels to all employees.	√		√		
32.	All database components, modules, or functionality which are intended to be used by a given application should be installed. Remove those that are not used.		√	√	√	
33.	Grant access to database files to only database administrators and system administrators.		√	√		
34.	The security model should have the flexibility to logically lock, disable, and remove accounts.	√	√		√	

4. Conclusion and Future Work

Database security threats will continue to be an issue as long as valuable data is shared across the world using Internet [9]. This paper offers a database policies and security solutions for database. Security policies of the DB provide great concern in the favour of security with concerning policies. The efforts to devise more security techniques will continue in future to further improve the security of database.

References

- [1] http://en.wikipedia.org/wiki/Database_security#Database_activity_monitoring.28DAM.29.
- [2] Sushil Jajodia, "Handbook of database security: applications and trends".
- [3] E.B. Fernandez, R.C. Summers, and C. Wood, "Database Security and Integrity," Addison-Wesley, February 1981.
- [4] James M. Slack, Elizabeth A. Unger, "A Model of Integrity for Object-Oriented Database Systems," Proceedings of the 1992 ACM/SIGAPP Symposium on Applied computing: technological challenges of the 1990's, April 1992.
- [5] R.Fagin, "On an Authorization Mechanism," ACM Trans.Database Systems, vol.3, no.3, pp.310-319, 1978.
- [6] A. Eisenberg and J. Melton, "SQL: 1999, Formerly Known as SQL3," SIGMOD Record, 1999.
- [7] Silvana Castano, Mariagrazia Fugini, Giancarlo Martella, and Pierangela Samarati, Database Security.
- [8] <http://www.stanford.edu/dept/its/docs/oracle/10g/server.101/b10743/security.htm#i2332>.
- [9] Elisa Bertino, Pierangela Samarati, Sushil Jajodia, "High Assurance Discretionary Access Control for Object Bases,"

Proceedings of the 1st ACM conference on Computer and communications security, December 1993.

- [10] Hassan A. Afyouni, "Database Security and Auditing: Protecting Data Integrity and Accessibility".
- [11] Craig S. Mullins , "Database Administration: The Complete Guide to Practices and Procedures".
- [12] Eduardo B. t, Rita C.,Summers, and Christopher Wood, "Database security and integrity".

Biological Sequence Matching Using Boolean Algebra

Nivit Gill, Shailendra Singh

Department of Computer Science and Engineering
Punjab Engineering College,
Chandigarh

e-mail: nivitgill@gmail.com, shailendrasingh@pec.ac.in

Abstract- This paper proposes an algorithm for alignment of multiple biological sequences by direct comparison method using the logical operations of Boolean algebra. In this algorithm, dynamic programming is employed to align the sequences progressively and to ensure the optimal alignment of the sequences. The algorithm is tested on few sets of real biological sequences taken from NCBI bank and its performance is evaluated using SinicView tool.

Keywords: Sequence alignment, Boolean algebra, Dynamic programming

1. Introduction

A widely accepted theory in biology is that all organisms evolved from a single cell. Every organism's genetic code can be represented as a sequence of characters, such as four base pairs of DNA and RNA, or twenty amino acids of protein, called biological sequences. Over time, due to some changes in their DNA sequence, many organisms evolved. These changes are called mutations. All living organism cell are composed of DNA molecules that are passed from one generation to other. This is the reason for some living organisms being biologically similar and some being distinct. The goal of bioinformatics is to align a large number of sequences in order to study their evolutionary relationships through comparative sequence analysis.

In bio-informatics, computations are applied to these sequences so as to represent, analyze and manipulate them. The prime objective behind this is to discover and record the role of genetics in an organism's biological characteristics. Sequence alignment is the most basic and essential module of computational bio-informatics and has varied applications in sequence assembly, sequence annotation, structural and functional prediction, evolutionary or phylogeny relationship analysis

Biological sequence alignment is the process of identifying one-to-one correspondence among sub-units of sequences in order to measure the similarities among them. This provides a base for other tasks of bio-informatics, such as to represent families or super-families of proteins, identify and represent conserved regions in bio-molecules which are correlated with structure and function, discover the evolutionary history of biological sequences. Sequences that show a high degree of similarity have

similar structure and function, and such sequences are useful in deducing evolutionary or phylogenetic relationships among organisms.

In this paper, we propose to align multiple biological sequences by matching the sequences using Boolean logic. In the proposed method the given biological sequence is first encoded in binary form, and matched using Boolean the operators to determine the match percentage of all the pairs of sequences [10]. This match percentage value is further used to order the sequences according to the similarity. The most similar pair is aligned first and the rest of the sequences are then aligned to this aligned pair.

The outline of this paper is: Section II discusses the basics of sequence alignment and its types and Section III provides related work. The Boolean algebra concepts and its usage in the proposed algorithm are provided in Section IV. Section V details the classical Needleman-Wunsch algorithm. The proposed algorithm is described in Section VI. Experimental results and their discussions are presented in Section VII and finally Section VIII concludes the paper.

2. Sequence Alignment

A biological sequence is a sequence of characters from an alphabet. For DNA sequence, character alphabet is {A, C, G, T}, for RNA sequence, alphabet is {A, C, G, U}, and for protein sequence, character set is {A, R, N, D, C, Q, E, G, H, I, L, K, M, F, P, S, T, W, Y, V}. A sequence alignment is a method of arranging biological sequences in order to search similar regions in the sequences. These similar regions provide functional, structural, and evolutionary information about the sequences under study. Aligned sequences are generally represented as rows within a matrix. Gaps ('-') are inserted between the characters so that identical or similar characters are aligned in successive columns. Gaps are also called *indels*, as they represent insertion of a character in or a deletion of a character from a biological sequence. Sequence alignment of two biological sequences is called *pair-wise sequence alignment*, and in case more than two biological sequences are involved, it is called *multiple sequence alignment*. [11]

Generally there are two approaches to sequence alignment: *global alignment* and *local alignment*. Global alignment "forces" the alignment to span the entire length of all query sequences. Local alignments identify regions of similarity within long sequences that are often widely divergent overall.

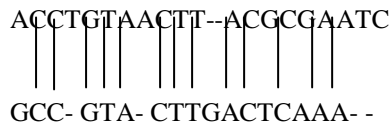

Figure 1. Global Alignment

Local alignments are often preferable, but can be more difficult to calculate because of the additional challenge of identifying the regions of similarity.

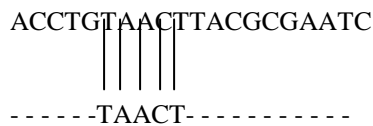

Figure 2. Local Alignment

A general global alignment technique is the Needleman-Wunsch algorithm, which is based on dynamic programming. The Smith-Waterman algorithm is a general local alignment method also based on dynamic programming.

Scoring Matrices are used to quantify the similarity achieved by an alignment [11]. These matrices contain a value (positive, zero or negative value) for each possible substitution, and the alignment score is the sum of the matrix's entries for each aligned pair. For gaps (indels), a special gap score is used--a very simple one is just to add a constant penalty score for each indel. The optimal alignment is the one which maximizes the alignment score. Commonly used matrices are PAM (Percent Accepted Mutations) matrices, BLOSUM (BLOCK SUBstitution Matrix), etc.

3. Related Work

With the exponentially growing biological sequence databases extensive demands have been put on the implementation of new fast and efficient sequence alignment algorithms. Most of the research work has been intended on primarily providing new algorithms with the main requisite of the meeting the demands of efficient sequence alignment.

Smith and Waterman proposed an algorithm to find a pair of segments one from each of two long sequences such that there is no other pair of segments with greater similarity (homology) [2]. In this local alignment algorithm, similarity measure allowed arbitrary length deletions and insertions. Needleman and Wunsch proposed a dynamic programming algorithm for performing a global alignment of two sequences [1]. A new algorithm for local alignment of DNA sequences had been proposed by Das and Dey [4]. Paul and Konar proposed direct comparison methods to obtain global and local alignment between the two sequences [5].

They also proposed an alternate scoring scheme based on fuzzy concept. Naznin, Sarker and Essam designed an iterative progressive alignment method for multiple sequence alignment by using new techniques for both generating guide trees for randomly selected sequences as well as for rearranging the sequences in the guide trees [9]. Cai, Juedes, and Liakhovitch proposed to combine existing efficient algorithms for near optimal global and local multiple sequence alignment with evolutionary computation techniques to search for better near optimal sequence alignments [3]. Y. Chen et.al proposed a partitioning approach, based on ant-colony optimization algorithm that significantly improved the solution time and quality by utilizing the locality structure of the problem [6]. Nasser et al. provided a hybrid approach of dynamic programming and fuzzy logic to align multiple sequences progressively [7]. They computed optimal alignment of subsequences based on several factors such as quality of bases, length of overlap, gap penalty. Anitha and Poorna suggested an algorithm for global alignment between two DNA sequences using Boolean algebra and compare the performance of the algorithm with Needleman-Wunsch algorithm [10]. Yue and Tang applied the divide-and-conquer strategy to align three sequences so as to reduce the memory usage from $O(n^3)$ to $O(n^2)$. They used dynamic programming so as to guarantee optimal alignment [8].

Of all the algorithms that had been proposed the prime prerequisite had been in the implementation where high speed in terms that it must involve smaller number of computational steps and lower memory consumption are of prime interest.

4. Applying Boolean logic

Boolean algebra (or Boolean logic) is a logical calculus of truth values (true or false), developed by George Boole in the 1840s. Whereas elementary algebra is based on numeric operations multiplication xy , addition $x + y$, and negation $\neg x$, Boolean algebra is customarily based on logical counterparts to those operations, namely conjunction $x \wedge y$ (AND), disjunction $x \vee y$ (OR), and complement or negation $\neg x$ (NOT) [12].

The proposed algorithm converts the given biological sequences into binary form, so that Boolean logic can be applied to them. The four nucleotides A, C, G and T are represented by 000, 001, 010, and 011 respectively, and the gaps as 100. Exclusive NOR (XNOR) function (see Table I) is a Boolean operator that produces true if both the inputs are true, otherwise false [13].

XNOR function is applied on two sequences encoded as binary strings. In the resultant string, replace the three consecutive ones by 1, otherwise replace by 0. Thus, in the final resultant string, 1 will correspond to a match and 0 to a mismatch.

Table 1. XNOR gate

A	B	A XNOR B
0	0	1
0	1	0
1	0	0
1	1	1

5. The Needleman-Wunsch Algorithm

In Needleman-Wunsch algorithm, a scoring matrix is calculated for the two given sequences A and B. One sequence is placed along row side and another column side. The size of the matrix is $(m+1)*(n+1)$ (m and n are the lengths of the two sequences). The optimal score at each matrix (i, j) position is calculated by adding the current match score to previously scored positions and subtracting gap penalties, which may evaluate to either a positive, negative or 0 value.

A matrix D(i, j) indexed by residues of each sequence is built recursively, such that

$$D(i, 0) = D(0, j) = 0$$

$$D(i, j) = \max \{ D(i-1, j-1) + s(x_i, y_j), \\ D(i-1, j) + g, \\ D(i, j-1) + g \}$$

subject to boundary conditions; here, $s(i, j)$ is the substitution score for residues i and j, and g is the gap penalty [14].

Using this D-matrix, then an alignment is calculated as: start from the bottom right cell, and compare the cell value with the three possible sources ((i-1, j-1) i.e. a Match, (i, j-1) i.e. an Insert, and (i-1, j) i.e. a Delete) to see which it came from. If it is same as Match, then A_i and B_j are aligned, if same as Delete, then A_i is aligned with a gap, and if same as Insert, then B_j is aligned with a gap.

6. Proposed Algorithm

We propose an algorithm for aligning multiple biological sequences (DNA, for example), using Boolean algebra. The proposed algorithm follows progressive approach to multiple sequence alignment, by first aligning the two most similar sequences, using Needleman-Wunsch algorithm. Then picking the sequences, one by one, from the rest, and aligning it to the aligned set of sequences. The proposed algorithm is composed of following two algorithms.

Algorithm MATCH_SEQ (A, B)

This algorithm finds the percentage of similarity (MatchPercentage) of the given two sequences A and B.

- Encode given biological sequences A and B into binary using binary encoding ($A='000'$, $C='001'$, $G='010'$, $T='011'$, and a gap='100'), into BinaryA and BinaryB, respectively.
- Perform exclusive NOR on BinaryA and BinaryB, resulting in a string P of length minimum of that of BinaryA and BinaryB

- In the string P, consider three bits at a time, if they all are equal to 1, then replace these three bits by a single 1, otherwise, replace the three bits by a single 0. Call the final resultant string as R.
- Count the number of 1's in R, as MatchCount.
- Divide MatchCount by length of R, to find MatchPercentage.

Algorithm ALIGN_SEQ (SeqDB, N)

This algorithm aligns the given set of N sequences SEQDB, progressively, and stores the aligned sequences in AlignSeqDB.

- Find the similarity between all pairs of sequences using algorithm MATCH_SEQ.
- Select the most similar pair of sequences. Remove this pair from the input set.
- Align this pair of sequences using traditional Needleman Wunsch algorithm. Store the aligned sequences in AlignSeqDB. Call these aligned sequences as RefSeqA and RefSeqB.
- From the set of remaining sequences, select a sequence Q which is highly similar to one of the aligned sequences.
- Find binary form of Q, BinaryQ.
- Align the sequence Q with the aligned sequences RefSeqA and RefSeqB. Find the match percentage of both aligned pairs, using MATCH_SEQ algorithm.
- Select the alignment of Q which gives higher match percentage. Say, it is Align_Q, and store it in AlignSeqDB.
- Remove the sequence Q from the given sequence set SeqDB.
- Repeat Step B, until all the biological sequences of SeqDB have been aligned.

7. Experimental Results and Discussions

The proposed algorithm was implemented using MATLAB™. Three different sets of influenza virus genome sequences (host: human): AH1N1, AH1N2, and AH1N3, for different countries were collected (randomly) from NCBI's Influenza virus resource site [16]. Various attributes of the tested sequence sets are listed in Table 2.

Table 2. Tested sequence sets

Influenza Virus type	No. of sequences	Average Length (bp)	Origin (Country/Continent)	Collection Year
AH1N1	34	1075	USA	2007-2009 (majorly 2007)
AH1N2	17	872	Asia	2007-2009
AH3N2	50	1033	USA	2008

All the three sets of sequences were aligned using the proposed algorithm and then the alignment results were evaluated using SincView – a visualization environment for comparison of multiple sequence alignment tools [15].

Fig. 3a, 4a and 5a show the alignment results for AH1N1, AH1N2 and AH3N2 virus sets respectively. The line graph (in red) shows the percent identity plot for the whole length of sequences. The second portion in these figures shows the detailed text alignments for the base pairs ranging from 541 to 640. The left side of the second portion lists the names of the sequences, and the right side shows the corresponding aligned sequences. The vertical red bar indicates an identity match in all the sequences. Fig. 3b, 4b, and 5b plot the distribution of percent identical rate of the three aligned sequence-sets respectively.

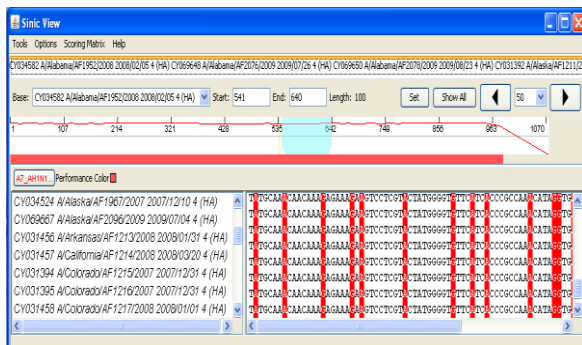

Figure 3a. Detailed text view of the AH1N1 sequence-set alignment results for the (541-640) base pairs

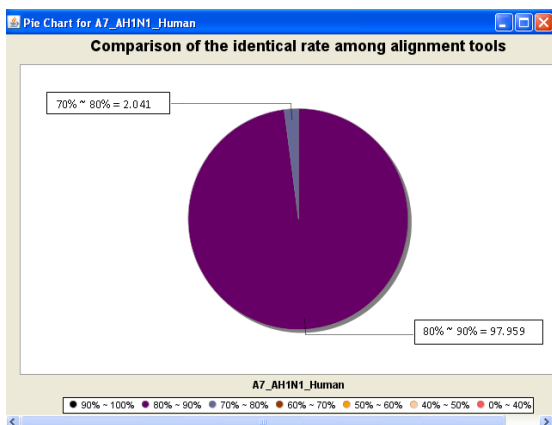

Figure 3b. Distribution of Per cent Identical rate in the aligned AH1N1 sequence-set

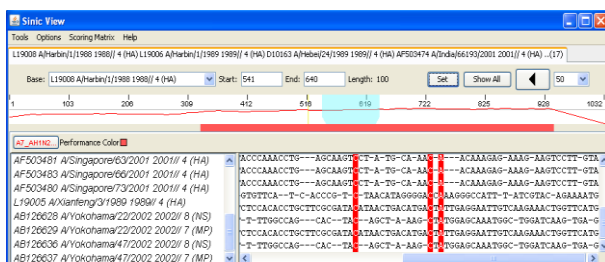
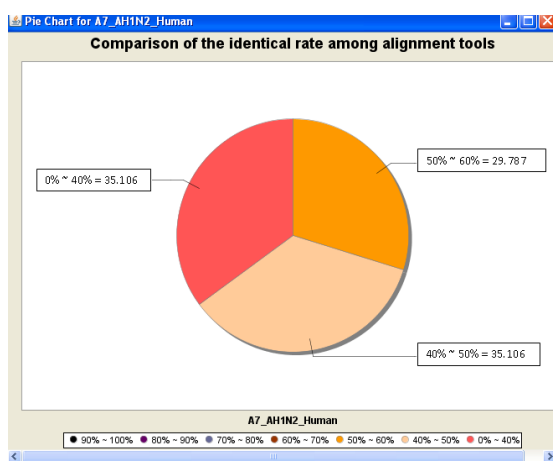

Figure 4a. Detailed text view of the AH1N2 sequence-set



alignment results for the (541-640) base pairs

Figure 4b. Distribution of Per cent Identical rate in the aligned AH1N2 sequence-set

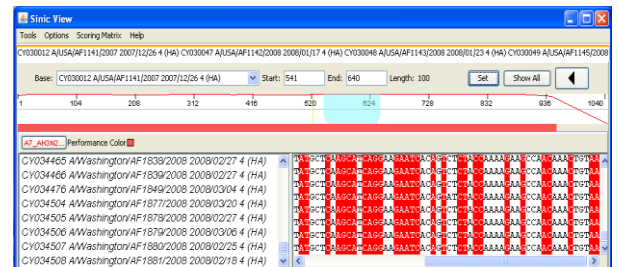

Figure 5a. Detailed text view of the AH3N2 sequence-set alignment results for the (541-640) base pairs

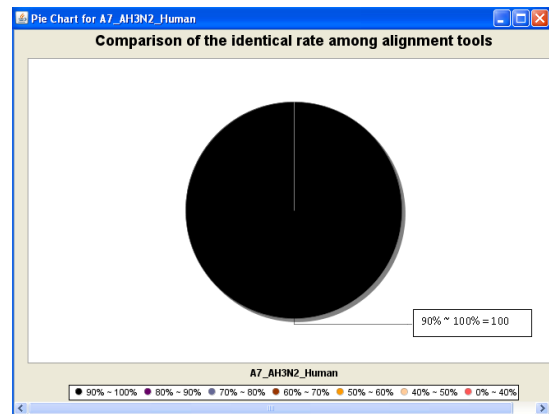

Figure 5b. Distribution of Per cent Identical rate in the aligned AH3N2 sequence-set

The following table (Table 3) briefs the distribution of percent identical rate of alignments of candidate influenza virus sequence-sets.

Table 3. Tabulation of Per cent Identical Rate Distribution

Sequence Set	Per cent Identical Rate	Distribution %
AH1N1	70 ~ 80	2.041
	80 ~ 90	97.959
AH1N2	0 ~ 40	35.106
	40 ~ 50	35.106
	50 ~ 60	29.787
AH3N2	90 ~ 100	100

A lot of variation in the results of the evaluation can be inferred. The origin of sequence (i.e. country/continent) and the time (year) of collection can be accounted for these differences. In the first set (AH1N1), the percent identity rate varies majorly in 80% - 90% range, as the sequence originate from USA and collection years are 2007-2009 (majority 2007). Second set's per cent identity rate is low as the aligned sequences belong to different countries in a continent and the collection year is also different. AH3N2 sequences show high almost 100% identity

rate as the sequences have been majorly collected from Washington (USA) and in the year 2008.

8. Conclusion

A new algorithm for sequence matching using Boolean algebra has been proposed and implemented. The match percentage of two sequences was calculated using the algorithm which determines the parts of sequences that match and that do not. The calculated match percentage guides in the progressive alignment of multiple sequences, which was done using dynamic programming. The experimental results show that the algorithm performs the alignment of sequences quite well and the nature and relationship of sequences reveal the alignment performance. The results obtained clearly indicated that the algorithm based on Boolean algebra is an efficient method for biological sequence matching.

References

- [1] S. B. Needleman and C. D. Wunsch, "A general method applicable to the search for similarities in the amino acid sequence of two proteins," *J. Molecular Biology*, vol. 48, pp. 443-453, 1970.
- [2] T. F. Smith and M. S. Waterman, "Identification of common molecular subsequence," *J. Molecular Biology*, vol. 147, pp. 195-197, 1981.
- [3] L. Cai, D. Juedes, E. Liakhovitch, "Evolutionary computation techniques for multiple sequence alignment", *Proceedings of the 2000 Congress on Evolutionary Computation*, 2000, pp. 829-835
- [4] Swagatam Das & Debangshu Dey, "A new algorithm for local alignment in DNA sequencing", *Proc. of IEEE Conference, INDICON 2004*, pp. 410-413
- [5] Bandyopadhyay, S.S.; Paul, S.; Konar, A., "Improved Algorithms for DNA Sequence Alignment and Revision of Scoring Matrix", *Proceedings of International Conference on Intelligent Sensing and Information Processing*, 2005, pp. 485-490
- [6] Y. Pan, Y. Chen, Juan Chen, Wei Liu, Ling Chen "Partitioned optimization algorithms for multiple sequence alignment", *Proceedings of the 20th International Conference on Advanced Information Networking and Applications*, 2006, pp. 5
- [7] Sara Nasser, Gregory L. Vert, Monica Nicolescu and Alison Murray, "Multiple Sequence Alignment using Fuzzy Logic", *Proceedings of the 2007 IEEE Symposium on Computational Intelligence in Bioinformatics and Computational Biology*, pp. 304-311
- [8] Feng Yue and Jijun Tang, "A Divide-and-Conquer Implementation of Three Sequence Alignment and Ancestor Inference", *2007 IEEE International Conference on Bioinformatics and Biomedicine*, pp. 143-150
- [9] Farhana Naznin, Ruhul Sarker, and Daryl Essam, "Iterative Progressive Alignment Method (IPAM) for Multiple Sequence Alignment", *Computers & Industrial Engineering*, 2009. pp. 536-541
- [10] V. Anitha and B. Poorna, "DNA Sequence Matching using Boolean Algebra", *2010 International Conference on Advances in Computer Engineering*, pp. 212-216.
- [11] David W. Mount, "Bioinformatics: Sequence and Genome Analysis", Cold Spring Harbor Laboratory Press
- [12] [http://en.wikipedia.org/wiki/Boolean_algebra_\(logic\)](http://en.wikipedia.org/wiki/Boolean_algebra_(logic))
- [13] http://en.wikipedia.org/wiki/XNOR_gate
- [14] http://en.wikipedia.org/wiki/Needleman%E2%80%93Wunsch_algorithm
- [15] http://biocomp.iis.sinica.edu.tw/new/SinicView_tr05005.pdf
- [16] <http://www.ncbi.nlm.nih.gov/genomes/FLU/Database/nph-select.cgi?go=database>

Total Power-Speed Optimization using Multi-Threshold voltage (Mvt) Library and Vt Swapping Flow

Miloni Ganatra¹, Niraj Jani², Jigneshpanwala³,

¹Department of Electronics and Communication, Nirma Institute of Technology, Ahmedabad

²Infochips Ltd. Ahmedabad (Sr. ASIC Engineer)

³Infochips Ltd. Ahmedabad (Physical Design Lead)

email-miloniganatra87@gmail.com

Abstract: Power dissipation is quickly becoming one of the most important in nanometer IC design. As technology scaling down leakage power increases. However, power and timing are often tradeoff during optimization. In this paper, I have propose a total power and delay optimization flow at synthesis stage and CTS stage. At Synthesis stage I have proposed flow using multivt library (Swapping of cells) which uses HVt (High threshold voltage), LVt (Low Threshold Voltage) and RVt (Regular Threshold voltage) cells. To build a clock tree I have proposed a flow using multivt library which includes pure HVt, pure RVt and pure LVt cells

Keywords: Synthesis, skew, Insertion delay, Latency, Clock Tree Synthesis (CTS)

1. Introduction

As the design size is shrinking to the ultra deep sub microns and density is increasing to millions of gates in a system on chip; large power dissipation in the chip due to sub-threshold leakage is becoming uncontrollable in the practical world. It is taking more importance as it is becoming dominant component for the overall power in the chip. There have been many researches going on recently to extend the battery life as the hand held mobile devices

are densely packed with multiple functionalities. The power consumption in silicon primarily consists of two main components, namely Dynamic power and Static power represented as:

$$\langle P_{total} \rangle = \langle P_{dynamic} \rangle + \langle P_{static} \rangle \text{---1.1}$$

The static power constitutes leakage power due to sub-threshold current and standby power.

The delay of logical gates increases with the increase in threshold voltage (High Vt), whereas the static power decreases with the increase in threshold

voltage. This can be represented by a simple gate delay equation:

$$\text{Delay, } T_d = (CLV_{dd}) / (V_{dd} - V_t) \alpha \text{---1.2}$$

In the equation 1.2, Td represents the propagation delay, CL is the load capacitance, Vdd is the supply voltage and Vt is the threshold voltage for the transistor. α is the coefficient and represents the effect due to shortening of the device channel length (scaling down technology).

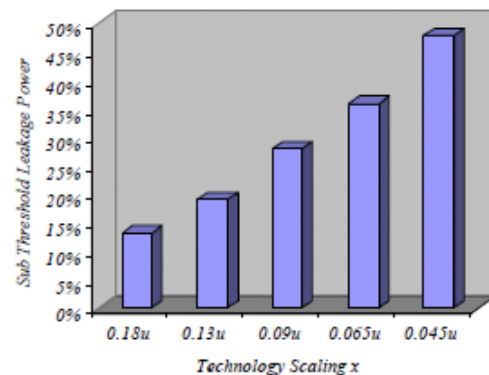

Figure 1: Shows the rate of increase of sub-threshold leakage power with the scaling of device technology.

From figure 1, It can be seen that the integrated circuits with 90nm and beyond, the leakage power contributes to the substantial percentage of total power. So there is a great need for the novel techniques to reduce the leakage power.

On the other hand, the interconnect delay has been dominating the gate delays causing many issues in meeting the chip performance parameters such as power, delay, area and signal integrity. In order to reduce the interconnect delay on a path, this needs to be buffered up using the chain of repeaters by accounting for the driver size and the load size in order to meet the delay constraint on that path. This is a very tedious task for the CAD tool although it might come up with a good trade-off. Designers try

different circuit techniques and schemes in order to minimize the leakage power to trade off the speed of the circuit. If one tries to control the leakage power, there happens the speed degradation of the circuit which is a real problem in any high performance design.

All the above factors that are being discussed are needed to be considered carefully at each level of design abstraction for the deep sub micron SoC designs. In this paper, I have propose a total power and delay optimization flow at synthesis stage and CTS stage. At Synthesis stage I have proposed flow using multivt library(Swapping of cells) which uses HVt(High threshold voltage),LVt(Low Threshold Voltage) and RVt(Regular Threshold voltage) cells. To build a clock tree I have proposed a flow using multivt library which includes pure HVt ,pure RVt and pure LVt cells

2. Multiple Vt Libraries for Leakage and Speed Optimization

Multiple Vt design approach is required for reducing leakage current Multiple Vt design is one of the important methods to design the deep submicron circuits in the power constrained era.

- Multi-Vt Library consists of different standard cells with different threshold devices
- ✓ HVT cells – High Threshold Voltage cells
- ✓ RVT cells – Regular Threshold Voltage cells
- ✓ LVT cells – Low Threshold Voltage cells

2.1 Characterization of Library Cells

The library cell characterization plays an important role as the design automation tools relies on the accuracy of the library. A typical low power library will have not only area and delay cost functions, but also will have power cost functions. There will be leakage power characterized for each input pin state. The target library for the technology mapping for leakage power should have the cells with multiple Vt cells

for maximum benefits in order to apply the multiple Vt schemes towards the leakage power optimizations. In this flow, two combinations of Vt are used: 1. High Vt and 2. Low Vt for the same logic function specified in the library. The third type is nominal Vt is optional in this flow. This is the minimum requirement in the technology library in order to

pursue the leakage power optimization.. No other changes in the design procedures are required as the technology mapping handles them in order to utilize the multiple Vt technology.

Combinations of high Vt and low Vt can be used to characterize the complex Vt cells in the library apart from just high Vt and just low Vt cells. The library size would be reasonably larger in this kind of characterized libraries. One more important thing to note is that the constant leakage power in the library would slowly go away as the constant models are not accurate for 90 nm and below.

2.2 Design Flow – LVt To HVt To LVt

Here in this design flow (Figure 2)shows that ,Once the data is get ,RTL synthesis and logic optimization will be performed using LVt (low threshold voltage cells) to optimize timing with high speed cells for meeting the timing target first because LVt cell has less delay but it has more leakage power . Then once the delay is met, the leakage power optimization will be ran with .target slack of zero and leakage power optimization will be done with only HVt cells (which has low leakage power but it has more delay).So it is necessary to swap HVt Cells with LVt cells. For that the path which is timing critical in that path only LVt cells are used so it reduces the delay.

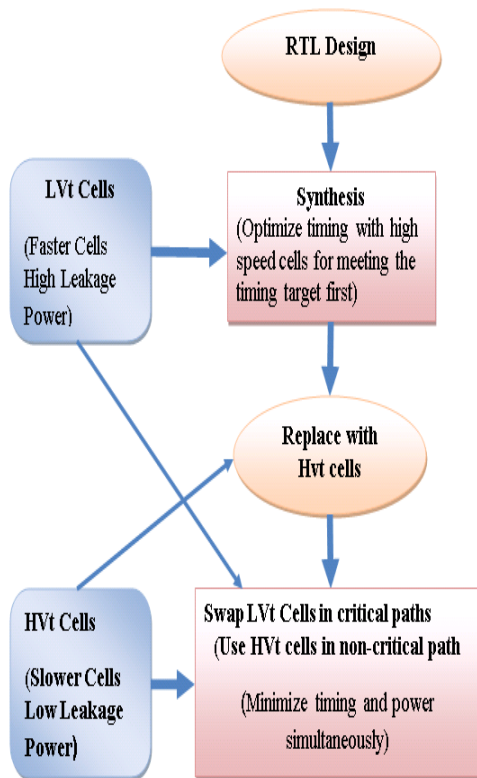

Figure 2. shows the design flow for swapping of LVt To HVt To LVt

2.3 Normalized delay and leakage current for a cell with different threshold voltages in 90nm Technology:

Table 1: Normalized delay and leakage current for a cell with different threshold voltages in 90nm Technology

Cell	HVT	RVT	LVT
Delay	663.6 ps	463.3 ps	374.9 ps
Leakage Power	1.7 nW	9.2 nW	23.8 nW

This Table 1 introduces the delay and leakage power for 90 nm technology for HVt ,Rvt,Lvt cells it shows that delay of HVt cell is maximum and leakage power of HVt cells are minimum compared to

another cells and delay of LVt cell is minimum and leakage power of LVt cell is maximum

3.Design experiments with multi-Vt libraries

3.1 Design experiments with multi-Vt libraries at Synthesis stage

- Synthesis = Translation + Mapping + Optimization
- **Translation** : It is Process that generates a gate-level netlist for an IC design that has been defined using a Hardware Description Language (HDL)
- **Mapping** : It maps to particular technology library
- **Optimization** : It is Step in the synthesis process that attempts to implement a combination of library cells that best meet the functional, timing, and area requirements of the design

Here in this Table2 it shows the experiment done at synthesis stage using multivt library.

This table 2 shows the results of gate count ,slack and leakage power using pure HVt ,pure Lvt and pure Rvt and using all three cells at synthesis stage

From this table 2, Three Vt's add one more dimension to performance/power optimization, Leakage power can be saved ,Silicon area is also improved. So at synthesis stage best option is to use HVT and LVT cells, because using that we can meet the timing ,slack is positive and leakage power is also controlled. So best way is to use the swapping of HVt and LVt cells(Use HVt cells in timing non critical path and use LVt cells in timing critical path . This Table2 results from the multivt design flow.

3.2 Design experiments with different threshold voltage cells at CTS Stage (Clock Tree Building).

CTS develops the interconnect that connect the system clock to all the cells in the chip. Goals of CTS:

- Minimizing Clock skew
- Minimizing Insertion delay

Skew is the difference in arrival of clock at two consecutive pins of a sequential element.

Insertion Delay: The delay from the clock definition point to the clock pin of the register

Table 2 : Design experiments with multi-Vt libraries at Synthesis stage

Cell	Pure HVT cells	Pure RVT cells	Pure LVT cells	LVT and HVT cells			LVT,RVT and HVT cells		
				LVT	RVT	HVT	LVT	RVT	HVT
Gates	99197	111617	100089	52889		58617	44569	39121	49516
Gate Count	99197	111617	100089						
Slack	-267ps	-100ps	>0ps	0ps			0ps		
Leakage Power	456uw	561uw	768uw	296uw			321uw		

Table 3: shows Result of Slack ,Skew ,Latency ,leakage power, Insertion delay at CTS stage.

Cell	HVT	RVT	LVT
Gate Count	117610	118853	118714
Slack (late)	-3056 ps	-859 ps	-690ps
Insertion Delay	1583 ps	1382 ps	1404 ps
Skew	318 ps	277 ps	167 ps
Latency	1511 ps	1314 ps	1154 ps
Slack (early)	-356 ps	-277 ps	-126 ps
Leakage Power	556.8 uW	680.1 uW	859.8 uW

Table 3 shows the results at CTS (Clock Tree Synthesis) stage. CTS is done with the using only HVT cells ,LVt cells and Rvt cells. From this Table 3,

- 1) If CTS is done with only HVT cells then delay of that path will be more but leakage power is less

than other two cells. so here leakage power is controlled.

- 2) It CTS is done with only RVT cells then delay and leakage both will increase
- 3) If CTS is done with only LVT cells then delay of that path is controlled, but leakage power increases.

So best way is to use LVT cells to built CLOCK TREE

Conclusion: In this paper, we propose the methodology to combine placement, gate sizing, and multiple-Vt cell swapping algorithms for leakage and total power optimization. The proposed simplistic power optimization script based on Flow experiments using multiple Vt technique and multivt swapping at synthesis stage achieved not only maximum sub threshold power benefits, but also met circuit speed and area reduction to the design. At Synthesis stage best way is to use the HVt and LVt cells using the multi v swapping flow. At CTS stage best way is to use LVt cells to built clock tree. This methodology can find the best optimal trade-off point between power and delay keeping the performance of the nanometer design.

References

- [1] W. Chuang and S. S. Sapatnekar, "Power vs. delay in gate sizing: Conflicting objectives," in *Proc. ICCAD*, pp. 463–466, Nov. 1995.
- [2] W. Choi and K. Bazargan, "Incremental placement for timing optimization," in *Proc. ICCAD*, p. 463, 2003.
- [3] Advanced ASIC chip Synthesis using Synopsis design Compiler ,Physical compiler and Prime Time.
- [4] CMOS Digital Integrated Circuit Analysis and design by Sung mo kang and Yusuf Leblebici
- [5] C. Chu and D. Wong, "Vlsi circuit performance optimization by geometric programming," in *Annals of Operations Research*, pp. 105:37–60, 2001.
- [6] B. Hu, H. Jiang, Q. Liu, M. Marek-Sadowska, "Synthesis and placement flow for gain-based programmable regular fabrics", *ISPD 2003*, pp. 197-203. Structured ASIC synthesis with logical effort consideration by using a conventional cell-based design flow.
- [7]<http://asicsoc.blogspot.com/2009/01/clock-definitions.html>
- [8]<http://asicsoc.blogspot.com/search/label/Sub%20Threshhold%20Leakage>

About the Authors

1. **Miloni Ganatra** pursued her B.E Electronics and Communication from Ahmadabad Institute of Technology, Ahmadabad (Gujarat University) .She is pursuing her M.Tech in VLSI Design from Nirma University. She is currently doing her M.Tech dissertation and research work from in area of VLSI Back-End Design (Physical Design) at EInfochips Ltd.Ahmedabad
2. **Niraj Jani** :He is Working as a Sr. Physical Design Engineer in e-infochips Pvt Ltd.,Ahemdabad having 3 years of Experience
3. **Jignesh panwala** : He is working as Physical Design Lead in e-infochips Pvt Ltd. Ahmedabad, having 10 years of experience

Role of Geographical Information Systems On Intersecting Functionalities of Banking and Insurance Sectors

Kalli Srinivasa Nageswara Prasad¹, Prof. S.Ramakrishna²

¹Research Scholar in Computer Science, Sri Venkateswara University, Tirupati, India.

² Professor in Computer Science Department, Sri Venkateswara University, Tirupati, India.

¹kallisinprasad@gmail.com , ²profsramakrishnasvu@gmail.com

Abstract: This paper describes how GIS is useful in a number of activities that the Banking & Insurance industry is involved in loans disbursements and recoveries, claims, risk analysis and management, catastrophe response and sales & marketing of insurance products created by RMSI to assist in these activities are also illustrate in the paper. Decentralization of the banking industry has lowered competitive entry barriers and competition is coming from both within and outside the industry. Banks need to desperate systems need to adopt advanced technologies like GIS, develop more effective marketing programs and overcome the difficulties of translating strategy into actions. This paper discusses the role of GIS in performing traditional functions by the banks along with newly invented and adopted functionalities, and importance of demographic information about customer behavior and lifestyle to support various activities undertaken by the banks. GIS is an effective tool for all types of insurance applications including risk assessment, resource deployment premium pricing, product marketing. An efficient GIS would not only help in the assessment post disaster situation, but can also be used for the disaster preparedness and management. This paper presents how the GIS software applications can be used for effective decision making by the interdisciplinary functionalities of banking and insurance. This paper focuses on an integrated approach in developing a GIS based integrated system that helps for banks and insurance sectors in achieving their business objectives. After reviewing the contribution of GIS in different application areas I came to an idea that GIS can provide a leading edge to the banks and insurance companies in front of their competitors. GIS along demographic information about customer behavior works as an analytical tool in both these sectors which can be useful for developing business strategies. . Already GIS has proved a very important tool in analyzing regional data and variations in traditional system. So it could give better solution for numerous business applications in both the banking as well as insurance sectors. This paper will present an outlay of how the GIS software applications can be used for effective decision making by the banking and insurance industry. GIS is recognized as an integral and indispensable information tool for not only to these two sectors but also other government and business

1. Introduction:

Geographical Information Systems (GIS) is a Spatial or Non-Spatial database as well as socioeconomic data used to store , analyze and retrieve related information. GIS has played an important role in predicting, responding to, managing from natural or human made disasters. GIS is a computer-based set of tools for the study analysis and visualization of maps/attributes and events. GIS technology integrates common database operations such as query and statistical analysis with the unique visualization and geographic analysis. GIS is now-a-days a very useful tool for decision making and makes these location related decisions and to analyze, query and map data in support of decision making process simple and precise if the inputs are correct. A GIS is not just an automated decision making system but also it is a tool can combine geographic and other types of data to generate Maps & Reports, by combining data from a variety of different sources such as corporate, commercial databases, and also able to handle the large inconvenienced volumes of data. The layers of information finding the best location of a Super Market, Identifying similar crimes in a city and finding the patterns and trends so on. Hence GIS works as a double edged sword for both the puzzling and traitorous sides of the business. Hardware, Software, Data, Methods, People are important components of GIS which are providing different valuable functionalities. Since the advent of GIS in the 1980s, many government agencies have invested heavily in GIS installations, including the purchase of hardware and software and the construction of mammoth databases. Indeed, GIS provides a very effective tool for generating maps and statistical reports from a database. In addition to the basic functions related to automated cartography and data base management systems, the most important uses of GIS are spatial analysis capabilities. Generation of maps and Generation of tabular reports are two widely realized fundamental functions of GIS.

Key words: GIS, Spatial Data, ATM, Maptitude.

GIS allows

1. Your organization to enhance your understanding of risk, customer interaction, and economic conditions using spatial models.
2. Improve profitability and operational performance by sharing knowledge-based decision making across departments.
3. Reduce business complexity through a more accurate analysis and neighborhood studies of real-world market conditions.
4. Increase your market understanding based on a single, common view of business performance using geospatial workflow and business processes.
5. Make an advantage of its flexibility, speed, accuracy and capability to handle large volumes of spatial data and non-spatial data.
6. GIS can permits digital mapping of conventional analog maps. As service provider, strongly empowered with technology and manpower, we enjoy matchless both in our service quality and relationships.

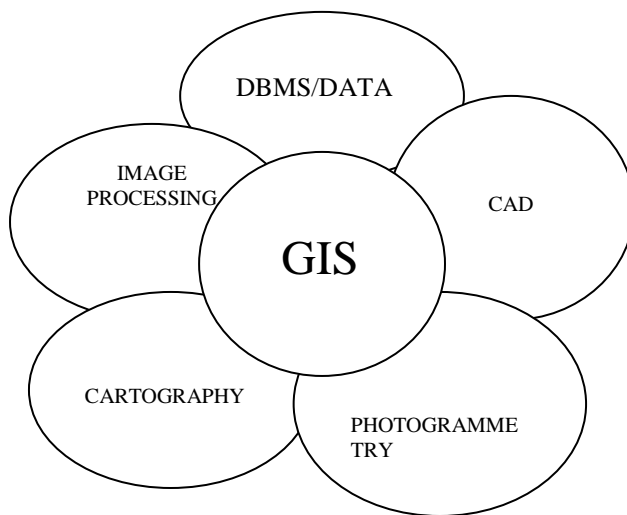

Figure1. Layout of Geographical Information System

Role of GIS in Banking Sector:

GIS plays an important role in various functional areas of banking in reach the targets, the various business objectives by providing support in decision-making and strategic planning which helps to bank. Basically banking is defined as the business conducted by a banking institution and the process of depositing & lending of money, Mortgages and Payments etc. A bank's primary function is to deliver financial services and products to the customers. Now in present days the banking industry has undergoing drastic changes, reflecting a number of developments. Many banks treat retail customers, larger business customers are managed by different separate ways. In Basic banking functions, computer software performs

regular operations like recording transactions, passbook maintenance, interest calculations on deposits, different types of loans, payments and withdrawals etc. All these said functionalities which are done at different branches of a bank interconnected by means of communication lines like telephones, satellite, internet etc. Not only the traditional functions but also specialized services like Stock marketing, Mutual funds etc.

GIS can more benefit to banks and change their total dimensionality. Today's banking environment is very competitive among public sector and private sector banks. Many of the latest and advanced features are adopting by banks such as Internet banking, Phone banking, Electronic banking, Credit card, Debit / ATM card, Mobile banking and Real Time Gross Settlement(RTGS) and also payable at par (PAP) cheque facility etc. GIS and its benefits to banks in different business objectives, they are Market analysis, Customer analysis, Competitor analysis etc. Marketing related to customer is an important operation and market analysis is necessary for successful operations of all the business to any bank's success. Traditionally marketing departments of banks really face many problems for identifying genuine customers for their finance products and services. Marketing is a question of demand of the customers and supply from organizations. These factors demand and supply if analyzed with the help of GIS will certainly provide interesting results. GIS application used as a tool to identify the locations of the bank customers and their characteristics which helps us to divide them into different market segments. Customer Relationship should have answer for Where is our customer location? And what are their characteristics like Market segmentation, Residential areas etc.?

Customer Relationship related GIS can also provide information about the potential customers, their power for high-end banking facilities. GIS applications have a tool known as a geo-coder that can convert a location reference such as a postal address to its corresponding position on a map. GIS can display where customers are located in relation to a branch and can also be used to identify future growth of the city and establish new areas to business. Banks seeking sites for location for expansion, also need information from localities, land costs, building availability and suitability, construction costs, local and state taxes, transportation costs to customers, some factors as the availability and quality of medical care in the area, the availability of other infrastructure such as telecommunications, sewer and water as well as factors related to quality of life. Using GIS based solutions banks can determine the maximum

number of branches. Banks can use GIS based solutions to rank service areas within a market according to viability for the concept.

There are two aspects are investigated how GIS can help bank for customer services, one is site selection of bank branches or ATMs and another is providing bank loan to customers.

By using GIS database they could,

1. Calculate the land value of the area by analyzing the neighboring area.
2. Creating a central database system to prevent the multiple loan takers utilize same plots as well as same properties may pledged.
3. Select the best location by using different attributes to establish a new bank (or) branches.

As a result, GIS can help banks to improve customer service management, general processes like data collection, data analysis, and data display.

As like customers the Competitors are also very important to be identified by any business firm because by ignoring them firms may have a disastrous effect on their business. So by using this type of analysis banks can identify their competitors. This analysis identifies the competitors and their customers on the Map, Analyze the reason for existing performance. Building a GIS support system based on "customer focus" in a bank is a good choice under the pressure of commercial competitions. How to optimize Web GIS for customer query from World Wide Web could be one opportunity for the future research .GIS can help in identifying those target groups spatial distribution by saving the advertising cost. Finding the new location to establish a branch for a bank for business expansion is really a challenging task as it requires substantial capital investment management wants to feel sure that they have selected the right expansion site. By using GIS, banks can analyze the performance of the branches of their banks and monitoring the branches and its performance using spatial components will have a high advantage. The GIS component of a branch review involves defining a business around the branch, finding the potentiality within that business area, and also identifying the nearby competitors.

Banks need Decision support while carrying out strategic planning. Former methods were more of a vague than accurate prediction. Banks can check the effects of branch closures, or relocations. Merger and Acquisition is an important activity in the banking sector. Mergers will require many branches to be closed if the economic benefits of the transactions are to be realized. GIS can help identify which branches can

be closed while minimizing inconvenience to customers being shifted to other nearby branches. The complete address and postal data combined with GIS software tools, permit us to first assign geographic locations to list of bank branches involved with the GIS software can further manage.

Now the new banking system has various physical assets such as ATMs and other electronic equipment indoor as well as outdoors to manage and observe. From installation to replacement, the condition of an asset throughout its lifecycle needs to be considered in a comprehensive management model in order to maximize the benefits of services to customers and users. GIS tools make it possible to operate, maintain, and upgrade physical assets cost-effectively. The future of retail banking is quite literally, in the customer's hands. GIS based solutions help the bank management to adopt innovative methods of automations to deliver the most efficient retail banking services to hold the customers. GIS based Real Time solution for the refill and management of ATMs provides highly effective approach to the cash management cycle. Distribution and refill of the cash to the ATM according to demand and also within the time is a major challenge in ATM management. "Auto detect" is one of the component provides real time data in order to best possible condition of ATMs servicing, resulting in improved efficiency and reduced costs. GIS based solution displays the ATMs on the map along with the cash status and cash distribution. Cash requirement for each day for a ATM can be predicted with the help of the history of cash transactions over a certain period and also with the help of population density and some other factors. The fleet management of the cash trucks involves scheduling and planning of routes for cash trucks and ensuring that the cash trucks run as per the schedule and disburses cash at ATMs in time. This is very difficult in Metropolitan cities where the number of cash trucks involved is very high and all these trucks performs iterative trips. If failure of this management affecting customer services at ATMs and has a chance to banks becoming unpopular. However GPS & GIS based fleet management systems provide the possibility of monitoring the movement of cash trucks at an affordable price.

Maptitude Geographic Information System (MGIS) software is the intelligent mapping solution for business, government, and education. Maptitude is a powerful combination of software and geographic data that provides everything you need to realize the benefits of desktop mapping and spatial analysis with a single, easy-to-use package. Maptitude is the ideal mapping software for use within the banking industry. Maptitude provides those in the banking and financial industry with the

geographical tools to obtain the answers to compete effectively, and to ensure compliance and customer service levels.

Mapitude provides powerful spatial tools for:

- Regulatory compliance.
- Bank and ATM site analysis.
- Bank network competitiveness/optimization.
- Customer management, identification, and targeting.
- Direct mail.
- Auditing.
- Web-based solutions.

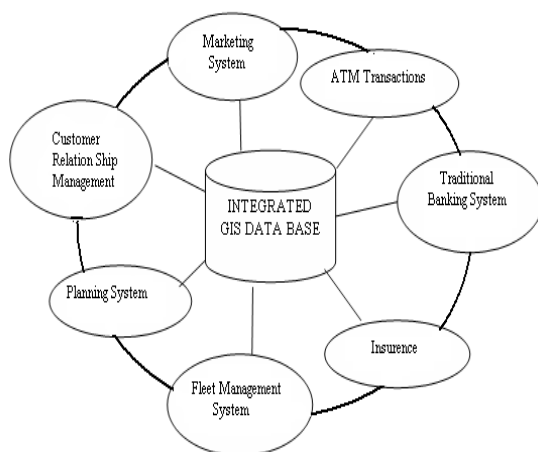

Figure2. GIS based Integrated Banking System

Role of GIS in Insurance Sector:

We all know that natural hazards can happen at any place or any point of time depending upon the probability of happening. The natural or human-made hazards are inevitable but assessment, emergency preparedness, and response such as prevention, discovery, planning, mitigation, insurance settlement are key areas where immediate attention is required. GIS act as an important tool in predicting, responding to managing and recovering from these above mentioned disasters.

General Layout of Insurance Companies:

1. **Life Insurance:** Take care of human life, i.e. take care about further survival of dependents when the prime person unfortunately lose their life.
2. **General Insurance:** Many types of policies are covered under this division. Those are Property Insurance, Health Insurance, Personal Accident Insurance, Travel Insurance, Motor Insurance, Burglary & Theft Insurance, Third party Insurance etc., This

Division plays a vital role in human being regular life.

The insurance companies generally pay huge amounts after any catastrophic events, and consequently their profit margins are affected. This is due to lack of data assessment on the risks associated with such catastrophes, it is a big business challenge to insurance companies. There are many ways insurers can use GIS for risk assessment and mitigation. Adding the geographic component is critical in finding the delicate balance between risk, profitability, and fairness to customers. GIS enables to locate the customers and resources, find marketing opportunities, provide customers with web-enabled access to information and improve customer service in the insurance sector. A central goal of every insurance company is to mitigate exposure to risk by ensuring a wide spatial distribution of policy holders. GIS provides ways to use maps to analyze and understand how geography affects insurance business. GIS is an effective tool for all types of insurance applications including risk assessment, resource deployment premium pricing, product marketing. GIS provides framework for pricing the policies especially for infrequent events i.e. earthquakes, tornadoes, floods, landslides, cyclones etc. GIS offer powerful tools to make a risk analysis of earthquake, simulating affects of flood for shelters.

GIS can be used by insurance companies to

1. Allocate various premium rates, as per the location of property in risk zone.
2. Demarcate areas of peak loss potential.
3. Map historical pattern of claims to understand the true spatial distribution of risk.
4. Aggregate the possible loss and provide backup plans.

GIS is not only user-friendly in respect of access and display but also the spatial analysis capability and the applicability to apply some important GIS functions such as Thematic mapping , Network analysis, Zoning, Simultaneous access to several layers of data etc. GIS & RS can be used to identify hazards when the hazards have been identified, their representations can be stored conveniently in GIS databases. Suppose information is essential for earthquake risk assessment includes properties of seismic faults, surface geology, water table levels and landslide occurrences. The GIS coordinating group within the organization will use it to design the GIS database, Reviewing Quality Assurance & Quality Control issues and also start estimating the benefits and costs of a GIS. In traditional maps data are static, fixed scale and coordination, difficult to combine multiple maps, difficult to copy and share between many users and also manual paper maps with inaccurate decision

process. In GIS data is easy to update, convertible scale & coordinate system, easy to combine multiple map layers. Multiple as well as simultaneous user accessibility is and dynamic digital maps with accurate decision process. Geospatial related technologies have already contributed in many areas including assessment, discovery planning, mitigation, insurance settlement and policy. There are number of ongoing projects to predict hazards, assess the risk to human life and property, assist response during an emergency, discover and recover from damage, plan and reduce for future hazards. GIS is predicting, managing and recovering from these above said disasters. GIS in its research and education initiatives appears to be as concrete support here.

The data and information are being made more available to public due to advances in and the acceptance of World Wide Web technology. Data acquisition and integration may be the single largest contribution area needed for emergency preparedness and response. There is a need to improve the representation of risk and human vulnerability. GIS is not representing the depth and richness of the theoretical frameworks and research on human vulnerability to environmental hazards remains incomplete. Risk and human vulnerability are much more dynamic than the representations are used in GIS. The GIS interface can allow query and manipulation at various levels and between multiple viewers at different sites. Basically GIS as a tool in analyzing the pros and cons of providing insurance to a customer acting as a decision making tool to allocate the right premium to the client. There by save the company from running into losses and safeguard the customer's interest. A GIS provider was creating connections and transformations for the geographic feature formats then in use worldwide.

The ArcGIS family of products is well suited to this implementation environment

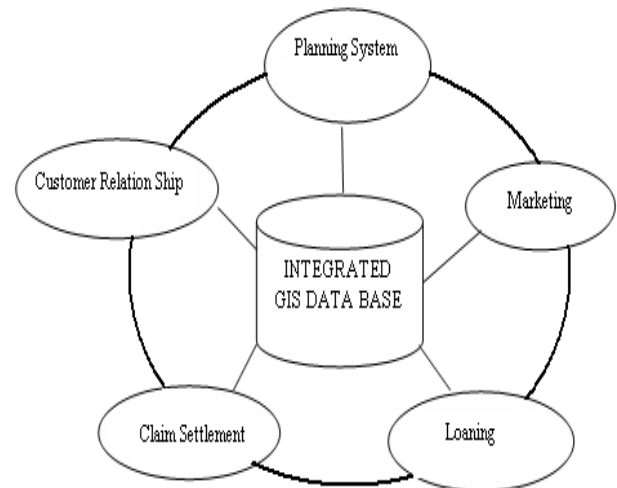

Figure3. GIS based Integrated Insurance System

Intersecting Functionalities of Banking & Insurance:

Many of the banks both private and public sector banks are operate bank accounts linked with Life insurance, Health insurance and Accidental insurance for their customers with some general insurance companies collaboration. Banks are also establish recently Marketing divisions for the purpose of study Stock Market to allow and encourage people / customers to invest in different funds through them, so banks can actively participating in Mutual Fund business . By traditionally banks can face some difficulty but now by using GIS implementing tools are made a lot of help for banking in identifying the accidental location and Network hospitals for insured patients to avoid mismanagement.

Nationally and internationally many insurance companies organize banking functionalities, housing loan activities and insurance linked mutual funds. Special teams are working for this schemes as separate departments in those companies. Those departments adopt GIS locator and other advanced GIS tools to performs all the functionalities effectively and efficiently. Insurance corporations use recent GIS technologies and provide higher benefits to the customers under Mutual Funds schemes. Insurance companies are also issuing credit cards to customers like as banks for effective / safe marketing by customers.

The banking and insurance sector reforms have encouraged private sector players to make forays into the business in collaboration with major international companies. Thus there is a need for intensive, futuristic and career oriented programs in these two areas i.e Banking and Insurance.

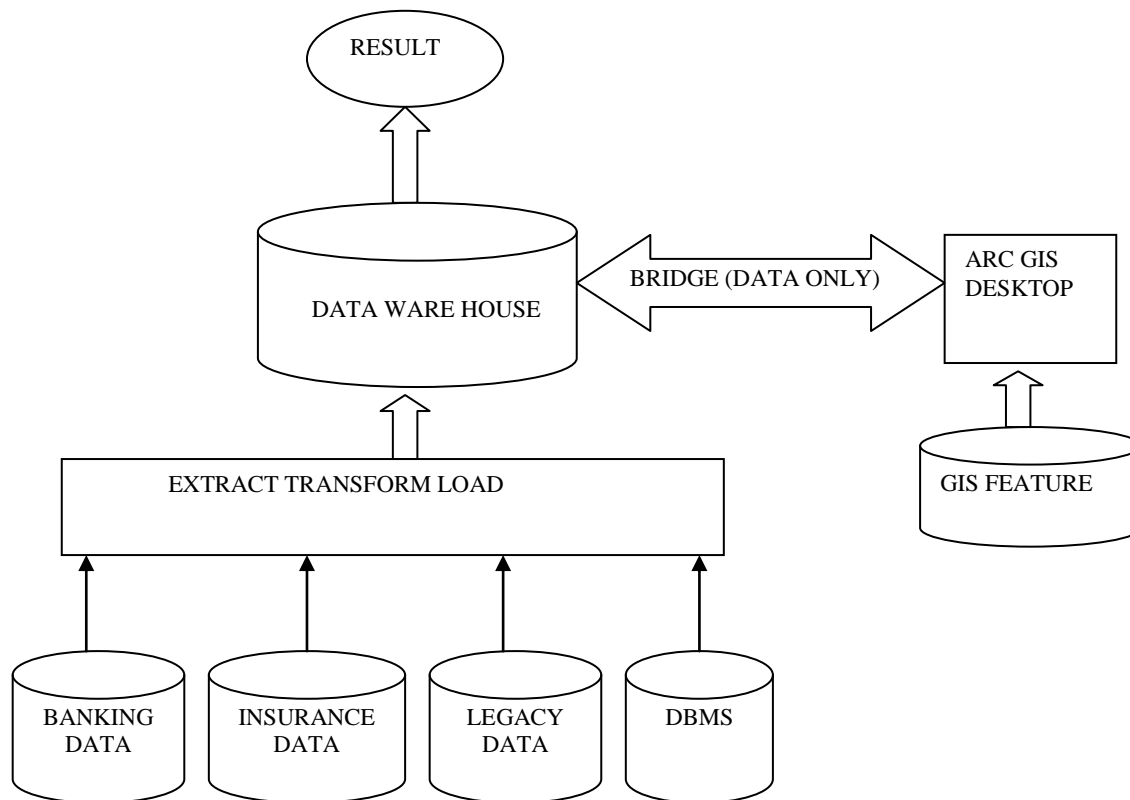

Figure 4. Extracting Result From Data Warehouse by using GIS Features.

References:

1. Mapitude: www.Caliper.com/insurance/default.html.
2. Insure pricing with GIS- Geospatial solutions, September 2000.
3. GIS is a decision making tool for insurance- Bimaquest-iv issue1.
4. www.gisdevelopment.net.
5. Geographic Information System and Economic Development.
6. Issues and Implications on Geographic Information Systems.

Author Biographies:



Kalli Srinivasa Nageswara Prasad has completed Msc(Tech)., Msc., M.S (Software Systems)., P.G.D.C.S. He is currently pursuing Ph.D degree in the field of Data Mining at Sri Venkateswara University, Tirupathi, Andhra Pradesh State, India. He has published 2 Research papers in International journals.



S.Ramakrishna is currently working as a professor in the Department of Computer Science, College of Commerce, Management & Computer Sciences in Sri Venkateswara university, Tirupathi, Andhra Pradesh State, India. He has completed M.Sc.,M.Phil., Ph.D.,M.Tech(IT).He is specialized in Fluid Dynamics & Theoretical Computer Science. His area of Research includes Artificial Intelligence , Data Mining & Networks. He has an experience of 23 years in Teaching field. He has published 30 Research papers in National & International Journals. He has also attended 13 national Conferences and 11 International Conferences. He has guided 14 Ph.D Scholars and 15 M.Phil Scholars.

A New Scheme for Detecting CMFs and Excluding Faulty Sensor Nodes from the Network

Hamideh Jafarian¹, Shahram Babaie², Ali Hosseinalipour³

Department of Engineering, Islamic Azad University-Tabriz Branch, Tabriz, Iran

¹ Jafarian_h12@yahoo.com

² Sh.babaie@iaut.ac.ir

³ Ali.Hosseinalipour@yahoo.com

Abstract: Development of wireless communications has provided the possibility of making small, low cost and low power sensors and caused the emerging of wireless sensor networks. Due to low cost sensor nodes and deployment of them in an uncontrolled environment, they are prone to have faults; so it is necessary to detect and locate faulty sensor nodes, and kept them out of the network; unless they can be used as communication nodes. In many cases, the range of failure occurred in the network is so wide and affect many sensor nodes and make common mode failures(CMFs); which multiple sensor nodes fail simultaneously in the same mode due to common reason. In this paper we consider CMF and represent a new fault detection algorithm for wireless sensor networks.

Keywords: Common mode failure, Fault detection, Fault recovery, Wireless sensor network.

1. Introduction

A wireless sensor network is made of a large number of small sensor nodes with low cost and low power consumption which consist of sensing, data processing, and communication components. Number of these sensor nodes can be very high and their distribution range can be very wide. Sensor nodes can be used in dangerous or in-accessible places. Due to Placement of sensor nodes in an uncontrolled environment, some of sensor nodes are prone to have faults; Fault is an incorrect state of hardware or software that results failure of a component [1]. Failures like environment, design shortage, operation and maintenance errors, phenomena and functional shortage can cause faults. In this paper we centralized on faults which occurred due to environment and phenomena. Sensor nodes even with failure have the ability to send, receive and process information [3]; this reduces the reliability in wireless sensor networks; so it is necessary to detect and locate the faulty sensor nodes, and kept them out of the network. Otherwise, these nodes can be used as communication nodes; which causes disturbance routing, false data gathering and incorrect decisions based on received information [1].

The goal of this paper is to locate the faulty sensor nodes in the wireless sensor networks and keep them out of the network. We propose and evaluate a fault detection algorithm to identify the

faulty sensor nodes. Many of the algorithms presented earlier allow the occurrence of common mode failure; this reduces the performance of wireless sensor networks. This paper aims to improve wireless sensor networks with detecting common mode failures.

The paper is organized as follows. We first briefly summarize the related work in Section 2. In section 3 we define the network model. In section 4 common mode failures described. The new algorithm for detecting faulty sensor nodes is proposed in Section 5. Simulation results are reported in Section 6. Finally we conclude our paper in Section 7.

2. Related Work

In this section, we briefly review the related works in the area of fault detection in wireless sensor networks.

In [11] an algorithm is presented for fault detection in wireless sensor networks. This algorithm is simple and has high accuracy to identifying faulty sensors. In this paper they use time redundancy to tolerate transient faults. But this algorithm can not recognize common mode failures.

In [3] Chen has introduced a fault detection algorithm in distributed wireless sensor network. Each sensor node makes a decision based on comparisons between its own sensed data and neighbors' data. Implementation complexity is low and the probability of correct diagnosis is very high. But this algorithm only detects permanent faults; and transient faults in communication that may occur for more nodes are ignored. Also this algorithm can not recognize common mode failures.

A faulty sensor identification algorithm is proposed in [4]. This algorithm is scalable and the computational overhead is low. To identify faulty sensor nodes each node compares its own data with neighbors' median data to determine its own status. If there was too much difference so the node is likely to be faulty. It also needs expensive GPS or other techniques to realize sensors' physical location.

In [7] a sensor fault detection scheme is proposed. In this work they used a record table, which records the history of all local decisions during the fusion process. Each node sends its local decision to the fusion center at every time step; the fusion center can identify a faulty sensor node by determining whether its behavior is very different from the others.

In [10], a failure detection scheme called MANNA is proposed for WSNs using management architecture. The manager has global view of the network and can perform complex tasks that would not be possible inside the network. However, this approach is too expensive because it requires an external manager to do tasks and communicates between nodes.

3. Network Model

We assume a square heterogeneous WSN which has three kinds of sensor nodes named L, H and K; number of H and K sensors are less than L sensors and have larger transition range, better computational capabilities, high memory and higher energy than L sensor nodes.[2] All sensor nodes are randomly deployed in network. The sensor network is divided into several small cells, and neighbor cells are filled with different colors, white or black, as illustrated in Figure1.

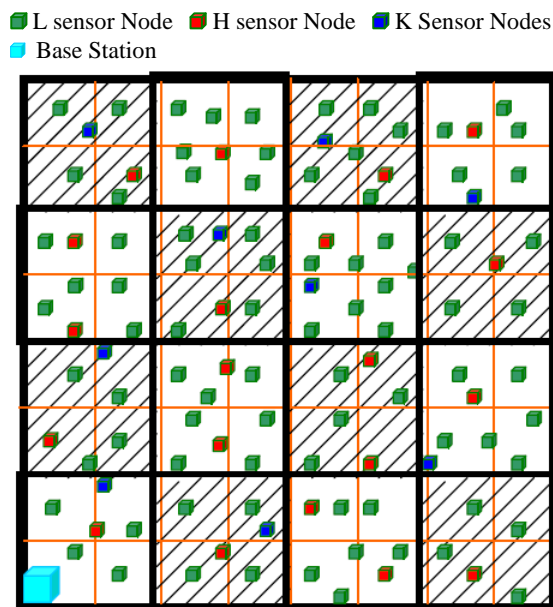

Figure 1: A heterogeneous WSN

Each sensor node has the ability to identify its neighbors located within its transmission range; where each node S_i broadcasts a hello signal to its neighbors. All nodes which are located at the transmission range of the sensor and received hello signal, send back acknowledge signal. The main idea is that data sensed by a fault-free sensor node and its neighbors should be similar.

4. Common Mode Failure

Data sensed by two neighboring sensor nodes are similar when both of them are fault-free or both of them, because of a common reason, are faulty. In many cases, a failure domain is big enough to affect a lot of sensors and makes their data similar. This called common mode failure (CMF). Common mode failures are simultaneous failures due to a common cause in which multiple elements fail simultaneously in the same mode. In many fault detection algorithms

of wireless sensor networks each sensor node S_i compares its sensed data with neighbors data, sensed at the same time. If at last half of the neighbors had the same data with node S_i , this node will be determined as fault-free; and broadcasts its status to neighbor nodes. In CMFs, faulty sensor nodes recognize as fault-free because of common mode of failures; this reduces the reliability in wireless sensor networks.

For example consider conditions that lightning in a part of wireless sensor network causes the electrical overhead on the electrical circuits and makes CMFs. Figure2 shows an example of wireless sensor network with CMF, where black and yellow sensor nodes are faulty and yellow nodes have CMF; Other nodes are fault-free. If we use fault detection algorithms presented in [2, 3], all of the yellow sensor nodes, because of CMF and similar sensed data at the same time, are going to detected as fault-free. Area with CMF

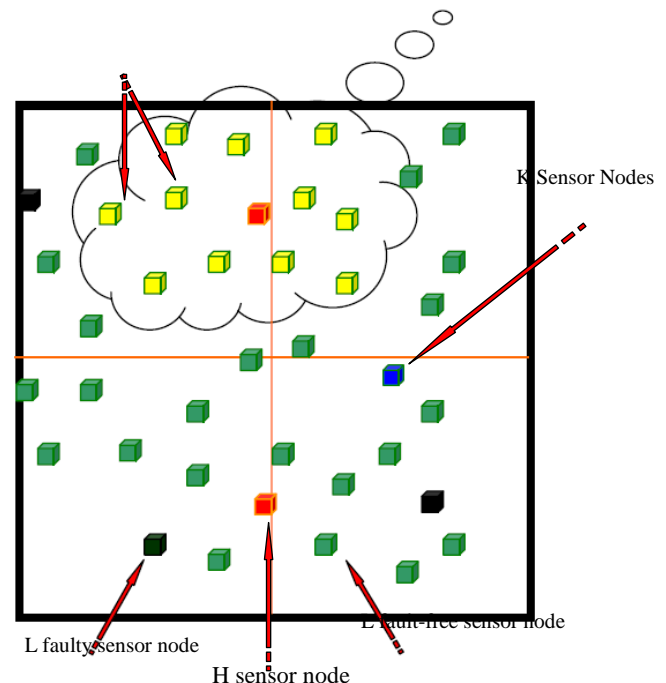

Figure 2: wireless sensor network with CMF

5. The Chessboard Clustering Scheme for Detecting CMF

In this section we introduce our fault detection scheme. We use Chessboard Clustering Scheme shown in figure1, for clustering our network. Transient faults could occur for most normal sensor nodes in sensor reading and internodes communication. So we use time redundancy to get over transient faults. Our algorithm has two phases. The first phase starts after deployment sensor nodes in the area. Nodes have the ability to identify that if they are placed in black or white cells. At first only H-sensors in white cells and all L-sensors are active. All H-sensors in black cells turn themselves off. Clusters are formed around the H-sensors in white cells and each L-sensor selects the closest H-sensor

as the cluster head. L-sensors close to these H-sensors become critical nodes. Then all active sensor nodes sense data and each H sensor located in white cells determines its likely status based on data comparison with one-hop member nodes after q different times comparison. After that all K sensors wake up, sense data, send data to all active H sensors placed in its transmission range and again sleep. According to data received from K sensors each active H sensor determines its deterministic status as GD or FT. In this step if H sensor's likely status and deterministic status be different from each other (it means LG and FT or LF and GD) then critical H sensor wake all H sensors in black cells located in its transition range up; these H sensors wake up, sense data, send data to critical H sensor and again sleep. According to data received from H sensors critical H sensor determines its final status. Then all H sensors with deterministic status broadcast their status to members in parallel. The second phase starts when H-sensors in white cells determine as faulty or run out of energy. In these cases critical H sensor sends a request message to closest H sensor located in black cells and wakes it up. Then activated H sensor sends back a response message to critical node and this node turn itself and all faulty members off. Activated H sensor forms a different set of cluster in the network; so previous critical L-sensors become non-critical, and previous non-critical L-sensors become critical nodes. Because critical sensor nodes consume much more energy than other sensor nodes, switching CHs and making new clusters balances the energy consumption among L-sensors, and increases the network lifetime. However because faulty sensor nodes turn themselves off so these nodes can not be used as communication nodes again and this increases reliability of WSN. Because all K sensor nodes are sleep and only wake up for a very short time, the reliability of data sensed by these nodes are very high and data comparison between these nodes and H sensors determines CMFs occurred in network.

6. Simulation Results

We used MATLAB to perform our simulation. We used 1000 L-sensor nodes, 40 H-sensor and 20 K-sensor nodes in this simulation. All nodes are randomly deployed in a square region of size 100×100 unit. Sensor nodes are randomly chosen to be faulty with probabilities of 0.05, 0.10, 0.15, 0.20, 0.25, and 0.30, respectively. We used the two metrics Detection Accuracy (DA) and False Alarm Rate (FAR) to evaluate our algorithm; where DA is defined as the ratio of the number of faulty sensor nodes detected to the total number of faulty sensors and FAR is the ratio of the number of fault-free sensor nodes diagnosed as faulty to the total number of fault-free sensor nodes. Figure3 and Figure4 shows DA and FAR for this simulation. Simulation results show that our fault detection algorithm achieves high detection accuracy and low false alarm rate even with a large set of faulty sensor nodes.

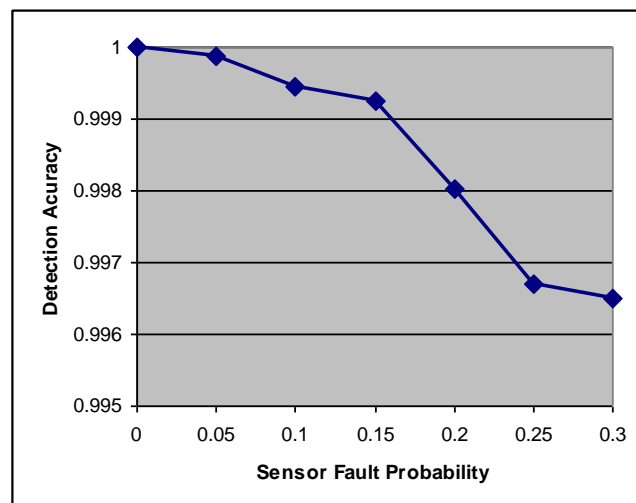

Figure 3: DA with average 10 members for each CH

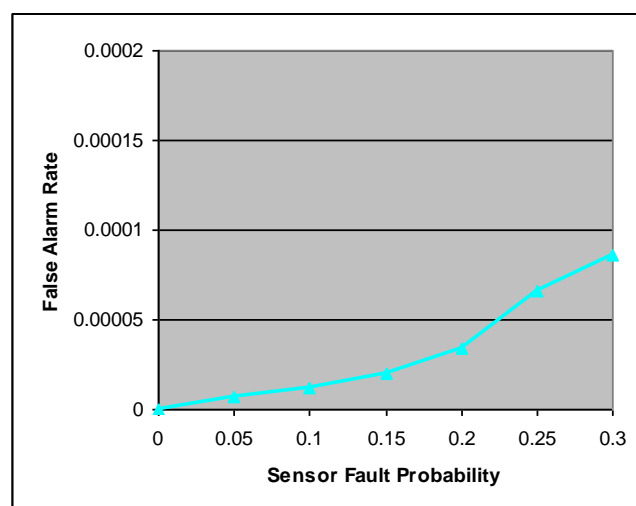

Figure 4: FAR with average 10 members for each CH

7. Conclusion

In this paper we proposed a faulty sensor detection technique based on Chessboard Clustering Scheme where each CH identifies its own status to be either "good" or "faulty", after two or three times competition, and then broadcast its deterministic status to its members. Our proposed algorithm decreases power consumption and increases network life time. Because K-sensors are always slept and wake up only for a short time, so their sensed data are going to be correct with 99%. So the reliability of determined status by these nodes are very high. We have simulated our proposed algorithm with MATLAB under different number of faulty sensor nodes in the same area. Our simulation results show that the DA is over 99% and FAR is as low as 0 when 30% sensor nodes are faulty. Simulation results support that our proposed algorithm can have a high detection accuracy and low false alarm rate with a large number of faulty sensor nodes existing in the network.

References

- [1] I.F. Akyildiz, W.Su, Y. Sankarasubramaniam, E. Cyirci, *Wireless sensor networks: a survey*, Computer Networks 38 (4) (2002) 393–422.
- [2] Yarvis M, Kushalnagar N, Singh N, et al, *Exploiting heterogeneity in sensor networks*, In Proceedings of the IEEE INFOCOM 2005, Miami, FL, March 2005.
- [3] M. Lee and, Y.Choi, *Fault detection of wireless sensor networks*, Computer Communications 31 (2008) 3469–3475.
- [4] M. Ding, D. Chen, K. Xing, and X. Cheng, *Localized fault-tolerant event boundary detection in sensor networks*, IEEE infocom (2005) 902-913.
- [5] F. Koushanfar, M. Potkonjak, and A.Sangiovanni-Vincentelli, *On-line Fault Detection of Sensor Measurements*. Sensors, 2003. Proceedings of IEEE Volume 2, 22-24, Oct. 2003, pp.974-979.
- [6] L. B. Ruiz, I.G.Siqueira, L. B. Oliveira, H. C. Wong, J. M. S. Nogueira, and A. A. F. Loureiro, *Fault management in event-driven wireless sensor networks*, MSWiM'04, October 4-6, 2004, Venezia, Italy.
- [7] A. Shrestha, L. D. Xing, H. Liu, *Modeling and evaluating the reliability of wireless sensor networks*, in Proceedings of Annual Reliability and Maintainability Symposium, Jan 22-25, 2007, Orlando, Florida, USA, pp. 186-191.
- [8] G. T. Edwards and I. A. Watson, *A Study of Common Mode Failures*, SRD-R-146, UK Atomic Energy Authority, Safety and Relia. Dir., 1979.
- [9] X. Luo, M. Dong, Y. Huang, *On distributed fault-tolerant detection in wireless sensor networks*, IEEE Transactions on Computers 55 (1) (2006) 58–70.
- [10] M. Yu, H. Mokhtar, M. Merabti, *Fault management in wireless sensor networks*, IEEE Wireless Communications (2007) 13–19
- [11] J. Chen, S. Kher, A. Somani, *Distributed fault detection of wireless sensor networks*, in: Proceedings of 2006 Workshop DIWANS, pp. 65–72.

Reconfiguring High Speed Networks

Naresh Kumar¹, Renu Vig² and Deepak Bagai³

¹University Institute Of Engg. & Technology, Kurukshetra University, Kurukshetra,

²University Institute Of Engg. & Technology, Panjab University, Chandigarh

³Punjab Engineering College (Deemed University), Chandigarh

{naresh_duhan@rediffmail.com, renuvig@hotmail.com, dbagai@yahoo.com}

Abstract: High speed networks have a number of switches which are interconnected and the workstations are connected to those switches through network interface card. Current distributed switch-based interconnected systems require high performance, reliability and availability. These systems changes their topologies due to hot expansion of components, link or node activation and deactivation. Therefore, in order to support hard real-time and distributed multimedia applications over a high speed network we need to avoid discarding packets when the topology changes. Thus, a dynamic reconfiguration algorithm updates the routing tables of these interconnected switches according to new changed topology without stopping the traffic. Here, we propose an improved deadlock-free partial progressive reconfiguration (PPR) technique based on UP/DOWN routing algorithm that assigns the directions to various links of high-speed switched networks based on pre-order traversal of computed spanning tree. This improved technique updates the routing tables at a very low computational cost when the network topology changes, either due to addition of switch nodes/links or removal of switch nodes/links. The proposed improved strategy makes very little modifications in the old routing table to give new updated routing table. The simulated results are compared with traditional PPR.

Keywords: Deadlock avoidance, dynamic reconfiguration, UP/DOWN routing, fault tolerance, high-speed networks.

1. Introduction

High-performance switch-based interconnected systems require communication between various workstations when there is change in network topologies due to hot expansion of components, failure of links or switches. In past years, many technologies have been proposed to reconfigure the network in case of addition/removal of links/switches without stopping the transmission of packets. Current high-speed switched networks (Myrinet[2,8], Advanced Switching[1], Infiniband[5], Tnet[9]) updates their routing tables when there is change in network topologies due to network components failures and addition of new one. In such cases a dynamic reconfiguration algorithm analyze the new network topology and updates the routing table by replacing the old routing function with the new updated routing function. Although both routing functions are deadlock-free still it may create deadlock during reconfiguration because one of the routing function may take turns that are not allowed in the other routing function by making a cycle in the network. In the literature, static reconfiguration (designed for Autonet[13,15] and Myrinet[2,8] networks) replaces the routing function from old to new by stopping the

network traffic. Hence it creates negative impact on the network service availability and the performance of the overall network degrades.

Many new schemes have been proposed recently to enhance network service availability while the network change over from one routing function to another. These new schemes updates the routing table of switched network during run time when there is any change in the network topologies due to addition/removal of links/nodes and are known as dynamic reconfiguration techniques. (Partial Progressive Reconfiguration (PPR)[3], Skyline[6], Double scheme[10], and Simple Reconfiguration [7]), NetRec[16] and Dynamically scaling Algorithm(DSA) [17]. These schemes are designed for the networks that uses distributed routing. Double Scheme requires extra resources like virtual channels for deadlock handling that occur during transition of old routing function to new routing function. Simple reconfiguration requires a special packet called token to avoid deadlock. In this scheme firstly all packets are transmitted by old routing function, then token and finally the packet transmission is based on new routing function. NetRec was proposed as a dynamic reconfiguration scheme to increase the network availability in the presence of a permanent node fault. It restores the network connectivity by building a tree that spans all immediate neighbours of the faulty node that are still connected to network. The NetRec Scheme[16] requires every switch to maintain information about nodes some number of hops away and is only applicable to wormhole networks. NetRec is extended to dynamically reconfigure the network for the case of newly joining nodes called Dynamically Scaling Algorithm (DSA). The solution in DSA is based on performing sequence of partial routing table updates, while dropping the user messages in all selected nodes until the restoration is completed. PPR requires a sequence of synchronizing steps to progressively update old forwarding table entries to new ones while ensuring that no cycles form. The PPR [3] approach correct an invalid UP/DOWN graph after change in network topology. Double Scheme[10] uses the concept of virtual channels to avoid deadlock while reconfiguring the network. Simple Reconfiguration [7] uses a packet called a token to avoid deadlock by ensuring that the packet which belongs to old routing function are transmitted first, then the token, and finally packet transmission is based on the new routing function. A management mechanism[11,12] and zero-configuration hierarchical UP/DOWN routing[19] has been discussed

for distributed calculation of the new routing function when there is any change in the switched-network topology. In this mechanism the distributed path-computation gives better performance when compared to existing centralized path-computation, still the routing function was updated statically, therefore degrades the performance.

In this research work, we propose to apply a new and very efficient dynamic reconfiguration strategy based on PPR that makes transformation of an invalid UP/DOWN graph (that is due to change in topology) into a valid UP/DOWN graph, while ensuring that there is no cycles in the graph to make it deadlock-free. Moreover, our dynamic reconfiguration does not use any additional resources such as virtual channels or special packet a token. This new proposed scheme gives better performance than PPR by distributing the traffic through optimize use of all links and reducing the congestion on root node of the spanning tree.

The next section discuss the concepts of UP/DOWN routing based PPR scheme and provides background information on previous studies of reconfiguration of UP/DOWN routing networks. Section 3 gives the details of improved dynamic reconfiguration strategy and assigning the directions UP/DOWN to the operational links based on pre-order traversal of spanning tree. In section 4, the performance of the proposed reconfiguration strategy is evaluated. Finally, section 5 concludes this research work and proposes some future work.

2. UP/DOWN Routing based Dynamic Reconfiguration (PPR)

PPR scheme is based on deadlock-free UP/DOWN routing algorithm [14] for irregular network topologies . The UP/DOWN routing algorithm is based on a cycle-free assignment of directions to the operational links in the network. For each link in the network, one direction is named up and the other is down. Deadlock avoidance is achieved by using legal routes. A packet never uses a link in the up direction after having used one in the down direction. Messages can traverse zero or more links in the up direction, followed by zero or more links in the down direction. Therefore, deadlocks are prevented and cycles in the channel dependency graph [4] are avoided. Major problem of old PPR is the random assignment of UP/DOWN direction to links between two or more nodes at the same label.

A sink node [3] does not have outgoing up-links (a node that is not the source of any link). There are no legal routes between any two sink nodes due to the restrictions imposed by UP/DOWN routing algorithm because each route would require a down to up transition, which is not allowed. So there is always a single sink node in directed acyclic graph based on UP/DOWN routing algorithm. A break node is the source of two or more links. This node breaks the cycles formation to avoid deadlock in directed graph. The graph of Fig 1 includes various break nodes like node j, e, d. A correct graph contains a single sink node for

UP/DOWN routing. It includes as many break nodes as necessary to break all cycles for deadlock freedom. The graph shown in Fig 1 is a correct graph. On the other hand, an incorrect graph does not meet the restrictions imposed in the correct graph. An incorrect graph has the absence of a sink node, presence of more than one sink node, or there are cycles in the graph. Fig. 2 tells about an incorrect graph with two sink nodes 'b' and 'c' after removal of node 'a' from Fig. 1 correct graph. A PPR scheme changes the direction of operational links to give a correct graph from an incorrect graph as shown in Fig. 3. In the literature, several algorithms have been proposed for constructing an UP/Down directed graph. Traditional proposals are based on the computation of a spanning tree which is built using a breadth-first search (BFS)[14], a depth-first search(DFS)[13], or a propagation-order spanning tree(POST) [15].

3. An improved PPR scheme based on pre-order traversal of spanning tree

Network topology changes due to addition/removal of switches/ links, then our dynamic reconfiguration scheme calculates a new routing function which ensures that packets that belong to the new routing function can not take turns in the old routing function, and vice versa. Therefore, packets of old and new routing functions can unrestrictedly coexist in the network without creating deadlocks. This improved PPR scheme is based on the concept of assigning the UP/DOWN directions to operational links by pre-order traversal of spanning tree in which a unique label is for each node of the graph. We also present lemmas to support that, when an UP/DOWN graph for the new topology is designed based on pre-order traversal of spanning tree, the routing function is updated without the risk of transient deadlocks.

Definition 1

Assume that two UP/DOWN directed graphs, G1 and G2, represented two network topologies. Then G1 and G2 are corrected.

Fig 4 presents UP/DOWN graph G1 which is correct. Fig. 5

shows again a correct graph G2 after removal of root node 'a' of graph G1 in Fig.4

Lemma1

Assume that an UP/DOWN directed graph G1 based on pre-order traversal of spanning tree is correct. Then, it is always possible to obtain a correct graph G2 from G1 when any node or link is added or removed.

Proof

In a correct UP/Down graph, each possible cycle must contain at least one node with two incoming up-links and at

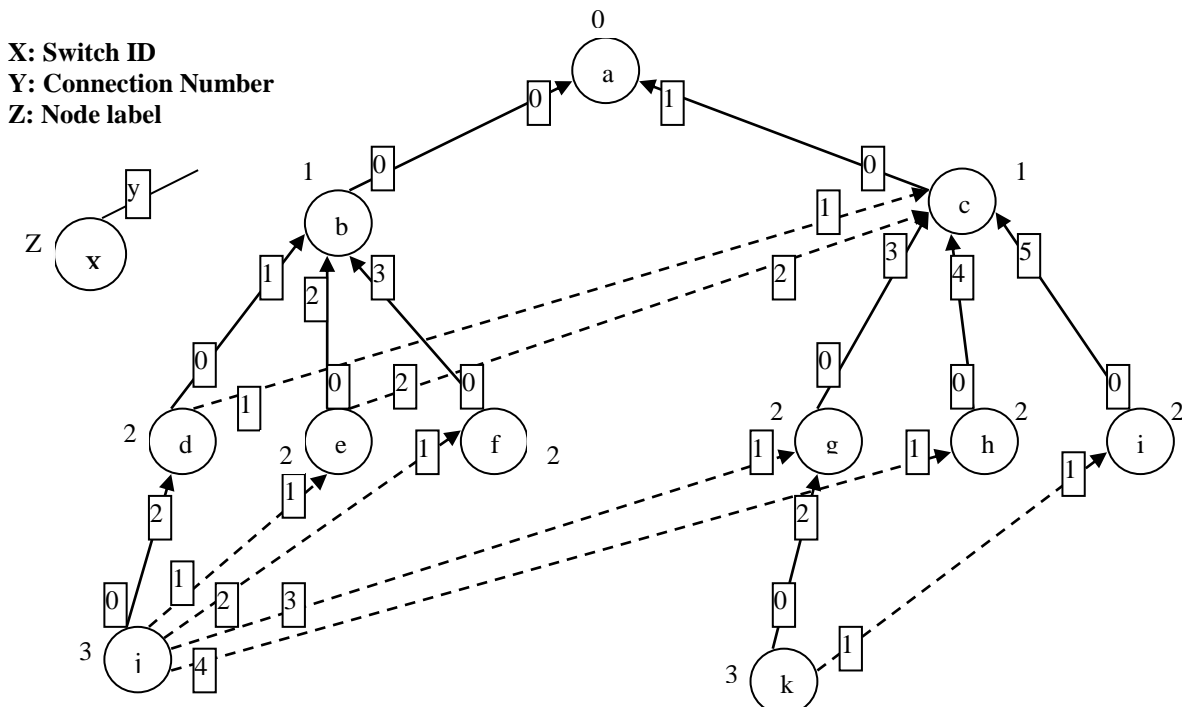

Figure 1: Example of UP/DOWN direction assignment in a switched network.

Table 1: Routing table based on UP/DOWN algorithm for Figure 1

Switch	a	b	c	d	e	f	g	h	i	j	k
a	[x]	[0]	[1]	[0,1]	[0,1]	[0]	[1]	[1]	[1]	[0,1]	[1]
b	[0]	[x]	[0]	[1]	[2,0]	[3]	[0]	[0]	[0]	[1,2,3,0]	[0]
c	[0]	[0]	[x]	[1,0]	[2,0]	[0]	[3]	[4]	[5]	[1,2,3,4,0]	[3,5]
d	[0,1]	[0,1]	[1,0]	[x]	[0,1]	[0]	[1,0]	[1,0]	[1,0]	[2,1,0]	[1,0]
e	[0,2]	[0,2]	[2,0]	[0,2]	[x]	[0]	[2,0]	[2,0]	[2,0]	[1,2,0]	[2,0]
f	[0]	[0]	[0]	[0]	[0]	[x]	[0]	[0]	[0]	[1,0]	[0]
g	[0]	[0]	[0]	[0]	[0]	[0]	[x]	[0]	[1,0]	[2,0]	[0]
h	[0]	[0]	[0]	[0]	[0]	[0]	[0]	[x]	[0]	[1,0]	[0]
i	[0]	[0]	[0]	[0]	[0]	[0]	[0]	[0]	[x]	[0]	[1,0]
j	[0,1,2,3,4]	[0,1,2,3,4]	[1,3,4,2,0]	[0,1,2,3,4]	[1,2,0,3,4]	[2,1,0,3,4]	[3,4,2,1,0]	[4,3,2,1,0]	[4,3,2,1,0]	[x]	[4,3,2,1,0]
k	[0,1]	[0,1]	[0,1]	[0,1]	[0,1]	[0,1]	[0,1]	[0,1]	[1,0]	[0,1]	[x]

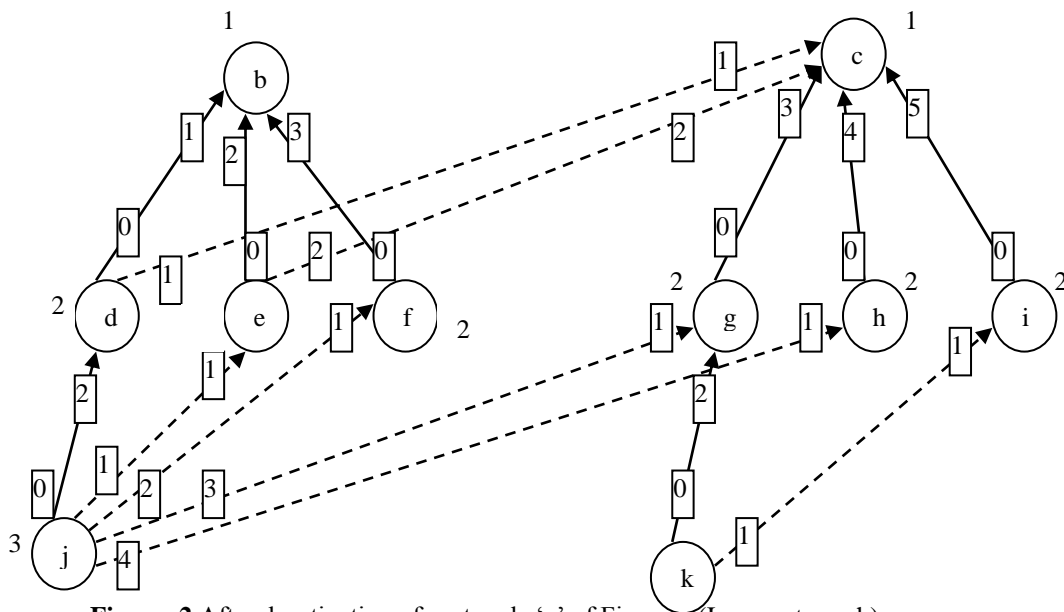

Figure. 2 After deactivation of root node 'a' of Figure 1 (Incorrect graph)

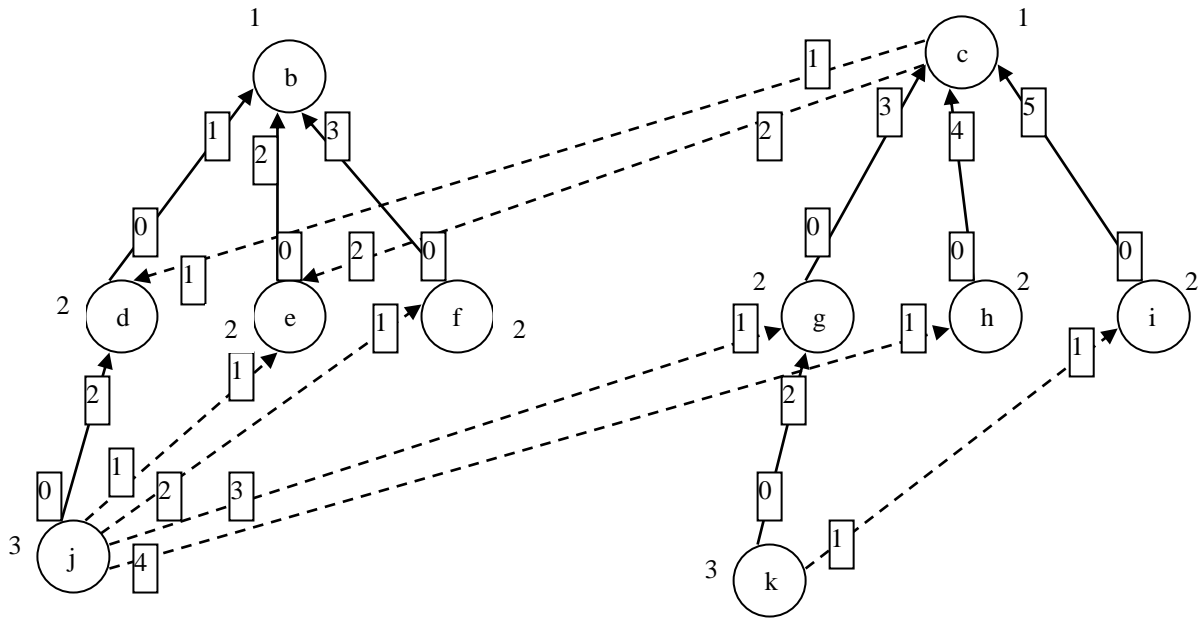

Fig 3 A new directed acyclic correct UP/DOWN graph after deactivation of root node 'a' of Fig. 1 (new correct graph after deactivation)

Switch	b	c	d	e	f	g	h	i	j	k
b	[x]	[2]	[1]	[2]	[3]	[1,2]	[1,2]	[1,2]	[1,2,3]	[1,2]
c	[1,2]	[x]	[1,2]	[2,1]	[1,2]	[3]	[4]	[5]	[3,4,1,2]	[3,5]
d	[0]	[1,0]	[x]	[0]	[0]	[1,0]	[1,0]	[1,0]	[2,1,0]	[1,0]
e	[0]	[2,0]	[0]	[x]	[0]	[2,0]	[2,0]	[2,0]	[1,2,0]	[2,0]
f	[0]	[0]	[0]	[0]	[x]	[0]	[0]	[0]	[1,0]	[0]
g	[0]	[0]	[0]	[0]	[0]	[x]	[0]	[0]	[1,0]	[2,0]
h	[0]	[0]	[0]	[0]	[0]	[0]	[x]	[0]	[1,0]	[0]
i	[0]	[0]	[0]	[0]	[0]	[0]	[0]	[x]	[0]	[1,0]
j	[0,1,2,3,4]	[0,1,3,4,2]	[0,1,2,3,4]	[1,0,2,3,4]	[2,0,1,3,4]	[3,0,1,2,4]	[4,0,1,2,3]	[3,4,0,1,2]	[x]	[3,0,1,2,4]
k	[0,1]	[0,1]	[0,1]	[0,1]	[0,1]	[0,1]	[0,1]	[1,0]	[1,0]	[x]

TABLE 2: Routing table for Fig 3 based on old PPR after deactivation of node 'a' of Fig. 1

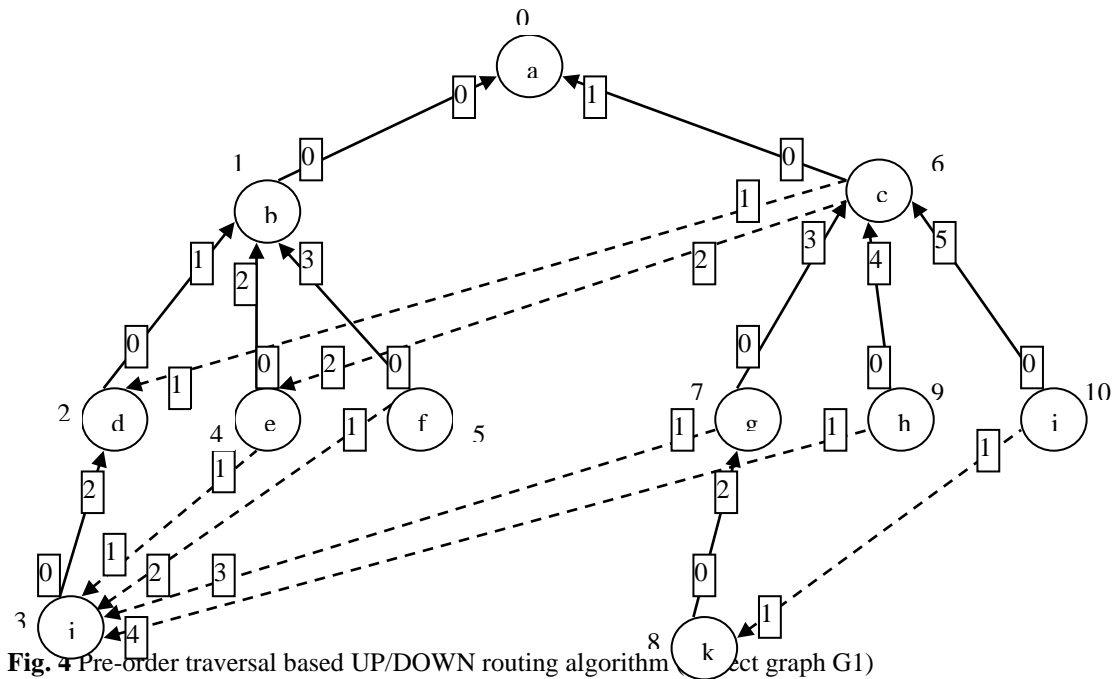

Fig. 4 Pre-order traversal based UP/DOWN routing algorithm (correct graph G1)

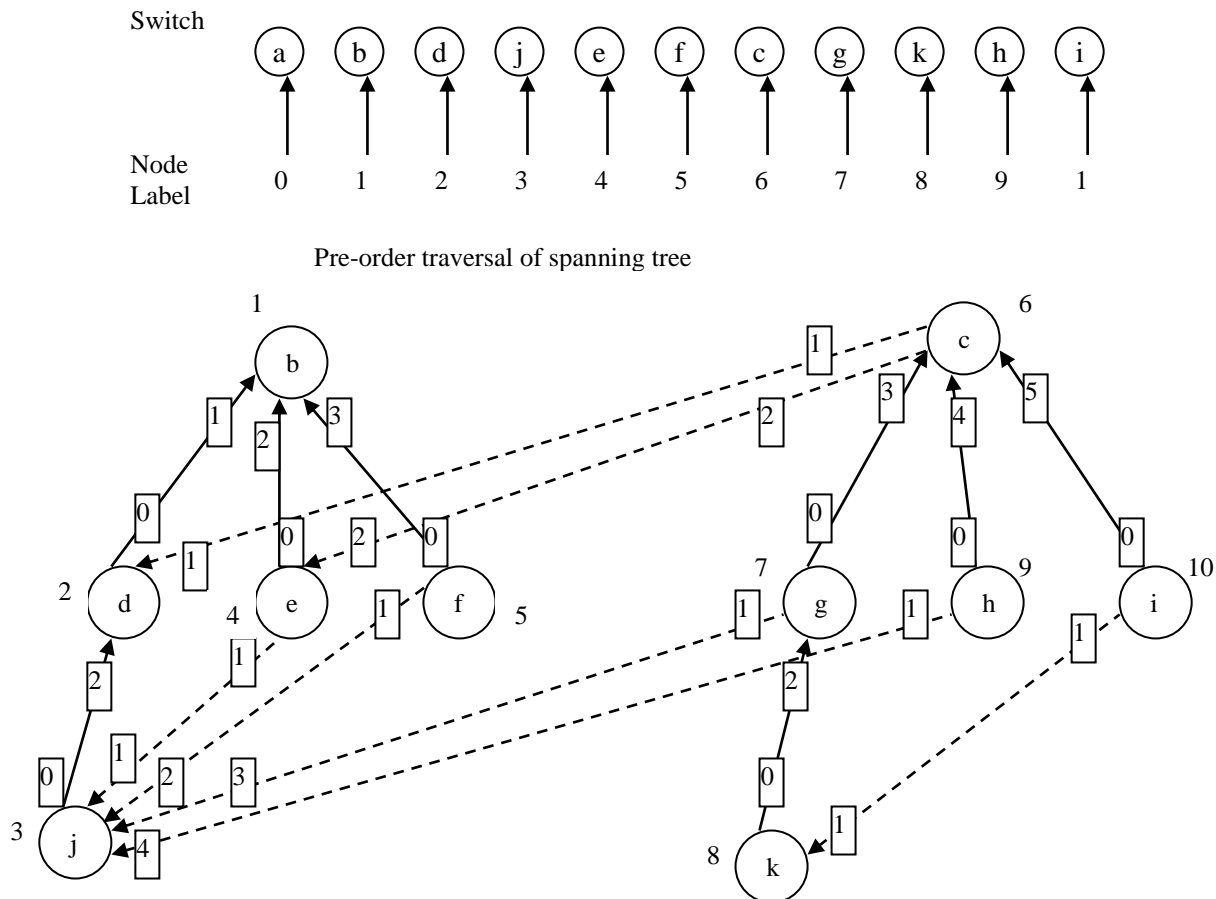

Fig 5 After deactivation of root node 'a' of G1 of Fig. 4 gives Correct graph G2

Switch	a	b	c	d	e	f	g	h	i	j	k
a	[x]	[0]	[1,0]	[0]	[0]	[0]	[1,0]	[1,0]	[1,0]	[0]	[1,0]
b	[0]	[x]	[0,2,1]	[1]	[2,1]	[3,1]	[0,1]	[0,1]	[0,1]	[1]	[0,1]
c	[0,1,2]	[0,1]	[x]	[1,0,2]	[2,0,1]	[0,1,2]	[3,2,1,0]	[4,2,1,0]	[5,3,2,1,0]	[2,1,0]	[3,2,1,0]
d	[0]	[0]	[1,0,2]	[x]	[0,2]	[0,2]	[1,2,0]	[1,2,0]	[1,0,2]	[2]	[1,2,0]
e	[0,1]	[0,1]	[2,0]	[0,1]	[x]	[0,1]	[1,2,0]	[1,2,0]	[2,0,1]	[1,0]	[1,2,0]
f	[0,1]	[0,1]	[0,1]	[0,1]	[0,1]	[x]	[1,0]	[1,0]	[1,0]	[1,0]	[1,0]
g	[0,1]	[0,1]	[0,1]	[1,0]	[1,0]	[1,0]	[x]	[0,1]	[0,1,2]	[1,0]	[2]
h	[0,1]	[0,1]	[0,1]	[1,0]	[1,0]	[1,0]	[1,0]	[x]	[0,1]	[1,0]	[1]
i	[0,1]	[0,1]	[0,1]	[0,1]	[0,1]	[0,1]	[0,1]	[0,1]	[x]	[0,1]	[1,0]
j	[0]	[0]	[0]	[0]	[1,0]	[2,0]	[3,0]	[4,0]	[3,1,0]	[x]	[3,1,0]
k	[0]	[0]	[0]	[0]	[0]	[0]	[0]	[0]	[1,0]	[0]	[x]

Table 3 Routing table for Fig 4 that uses Pre-order traversal based assignment of UP/DOWN direction to various operational links.

Switch	b	c	d	e	f	g	h	i	j	k
b	[x]	[1,2]	[1]	[2,1]	[3,1]	[1,2]	[1,2]	[1,2]	[1]	[1,2]
c	[1,2]	[x]	[1,2]	[2,1]	[2,1]	[3,2,1]	[4,2,1]	[5,2,1]	[1,2]	[3,2,1]
d	[0]	[1,2,0]	[x]	[0,2]	[0,2]	[2,1,0]	[2,1,0]	[1,0,2]	[2]	[1,2,0]
e	[0,1]	[2,1,0]	[0,1]	[x]	[0,1]	[2,1,0]	[2,1,0]	[2,1,0]	[1,0]	[2,1,0]
f	[0,1]	[0,1]	[0,1]	[0,1]	[x]	[1,0]	[1,0]	[1,0]	[1,0]	[1,0]
g	[0,1]	[0,1]	[0,1]	[0,1]	[1,0]	[x]	[0,1]	[0,2,1]	[1,0]	[2,1,0]
h	[0,1]	[0,1]	[0,1]	[0,1]	[1,0]	[0,1]	[x]	[0,1]	[1,0]	[0,1]
i	[0,1]	[0,1]	[0,1]	[0,1]	[0,1]	[0,1]	[0,1]	[x]	[1,0]	[1,0]
j	[0]	[1,0]	[0]	[1,0]	[2,0]	[3,0]	[4,0]	[3,1,0]	[x]	[3,1,0]
k	[0]	[0]	[0]	[0]	[0]	[0]	[0]	[1,0]	[0]	[x]

Table 4: Routing table for Fig 5 after deactivation of node 'a' of Fig 4

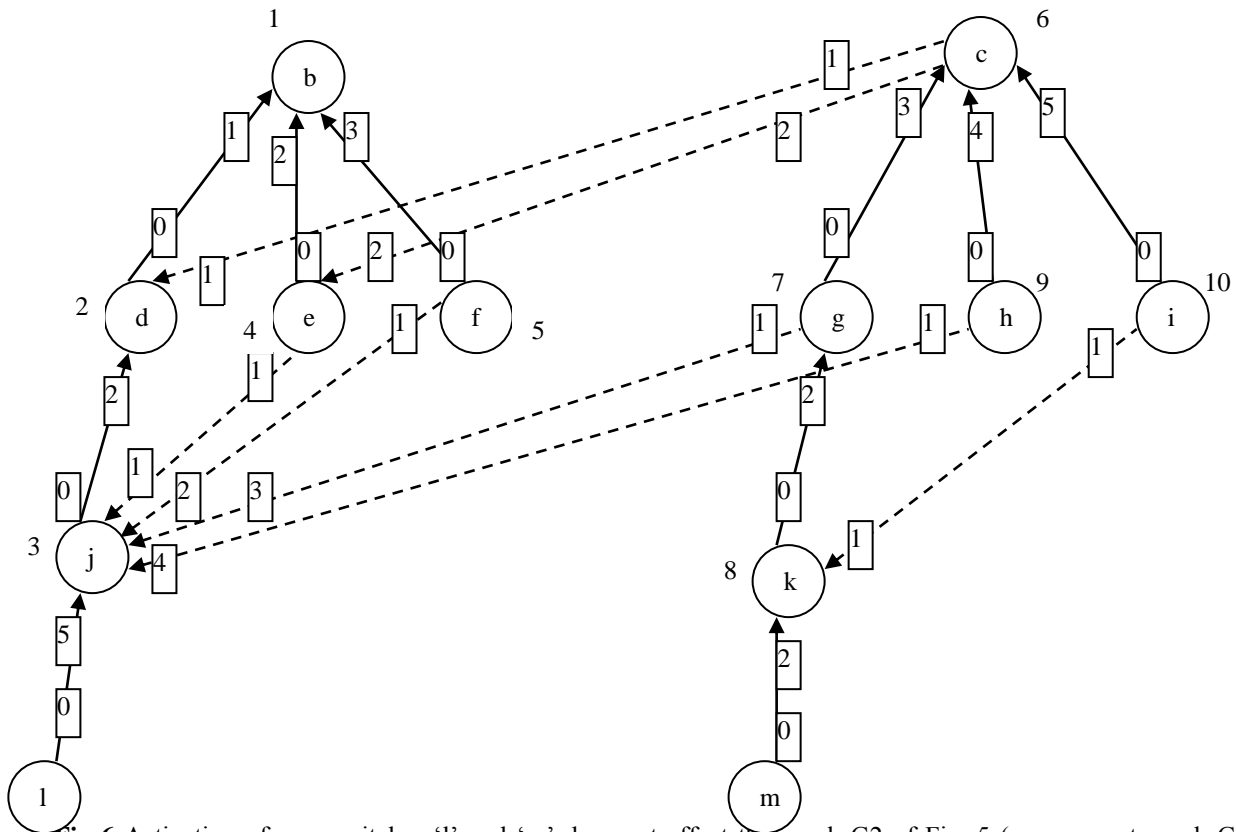

Fig 6 Activation of new switches 'l' and 'm' does not effect the graph G2 of Fig. 5 (new correct graph G3 after activation)

Switch	b	c	d	e	f	g	h	i	j	k	l	m
b	[X]	[1,2]	[1]	[2,1]	[3,1]	[1,2]	[1,2]	[1,2]	[1]	[1,2]	[1]	[1,2]
c	[1,2]	[X]	[1,2]	[2,1]	[2,1]	[3,2,1]	[4,2,1]	[5,2,1]	[1,2]	[3,2,1]	[1,2]	[3,2,1]
d	[0]	[1,2,0,]	[X]	[0,2]	[0,2]	[2,1,0]	[2,1,0]	[1,0,2]	[2]	[1,2,0]	[2]	[2,1,0]
e	[0,1]	[2,1,0]	[0,1]	[X]	[0,1]	[2,1,0]	[2,1,0]	[2,1,0]	[1,0]	[2,1,0]	[1,0]	[1,2,0]
f	[0,1]	[0,1]	[0,1]	[0,1]	[X]	[1,0]	[1,0]	[1,0]	[1,0]	[1,0]	[1,0]	[1,0]
g	[0,1]	[0,1]	[0,1]	[0,1]	[1,0]	[x]	[0,1]	[0,2,1]	[1,0]	[2,1,0]	[1,0]	[2]
h	[0,1]	[0,1]	[0,1]	[0,1]	[1,0]	[0,1]	[X]	[0,1]	[1,0]	[0,1]	[1,0]	[0,1]
i	[0,1]	[0,1]	[0,1]	[0,1]	[0,1]	[0,1]	[0,1]	[X]	[1,0]	[1,0]	[1,0]	[1,0]
j	[0]	[0,1]	[0]	[1,0]	[2,0]	[3,0]	[4,0]	[3,1,0]	[X]	[3,1,0]	[5]	[3,1,0]
k	[0]	[0]	[0]	[0]	[0]	[0]	[0]	[1,0]	[0]	[X]	[0]	[2]
l	[0]	[0]	[0]	[0]	[0]	[0]	[0]	[0]	[0]	[0]	[X]	[0]
m	[0]	[0]	[0]	[0]	[0]	[0]	[0]	[0]	[0]	[0]	[0]	[X]

Table 5 Routing table for Fig 6 after activation of node 'l' and 'm' to Fig. 5

least one node with two outgoing up-links. For each possible cycle in G2, we have three options with respect to break node placement. Thus, it is always possible to construct a correct graph G2 which is also like G1. A correct graph G1 in Fig 4 gives a new correct graph G2 in Fig 5 after removal of root node 'a' with new root node 'b' or correct graph G3 as shown in Fig 6 from graph G2 while addition of new nodes 'l' and node 'm'

Lemma 2

Assume that two up/down directed graphs G1 and G2 where G2 is also correct after removal of any node or link of correct graph G1

Proof

Assume that G2 is a subgraph of G1 in which each link that connects a break node in G1 with the corresponding break node in G2 is suppressed, and that G2 is a correct UP/DOWN graph. Then, according to lemma 1, we can guarantee that G2 is also a correct UP/DOWN graph. Thus it is possible to define a fully connected deadlock-free routing function R2 over G2. R2 satisfies the routing-restrictions of both G1 and G2 since all the break nodes either have the same locations or have been removed.

3.1 Preorder Traversal Based UP/DOWN direction assignment to various link.

- 1) Computing a spanning tree.
- 2) Preorder traversal of spanning tree and assign labeling

to nodes through horizontal traversal based distance of each node from root node.

- 3) Next assigning UP/DOWN directions to various links likewise previous strategy.
- 4) Finally, updation of routing tables

3.1.1 Switch Deactivation

The deactivation of switch including the root node produces a new root node. Switch deactivations imply that messages routed to remove components must be discarded. In this case, shorter reconfiguration time implies less discarded messages which is the characteristic of this improved PPR scheme.

3.1.2 Switch Activation

When a new switch is added, a direction must be assigned to the links connecting to it in such a way that the down direction goes toward the new switch and it should not produce cycles in the directed graph.

4. PERFORMANCE EVALUATION

In this section, we evaluate the performance of the improved PPR algorithm proposed in section 3. Our dynamic reconfiguration scheme is compared to traditional PPR scheme. New mechanism requires very less computations time for updation of routing function from old one to new, when there is change in network topology due to addition or removal of switch nodes or links.

4.1 Switch Model

A switch consist of crossbar, a routing and configuration unit, and many full-duplex links. The routing and configuration unit provides the output channel for multiple packets to cross a switch. Table look-up routing is used. Each input channel has 2 set of buffers: user and control buffers. Control buffers handle control messages generated in each reconfiguration process when there is any change in network topology. We have assumed that one clock cycle is required to access the routing table and provide the output link for the message.

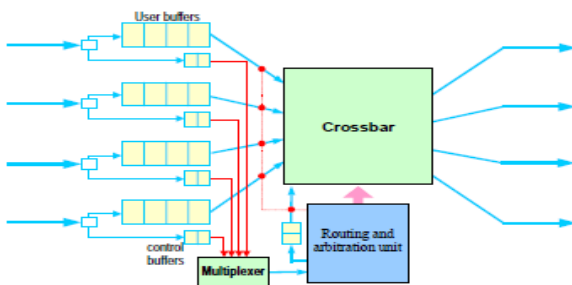

Fig . 7 Switch Architecture

4.2 Network Model

The high-speed switched networks are consist of a set of switches interconnected through point-to-point links and hosts are connected to those switches through a network interface card in a irregular fashion. We have evaluated the performance of different sizes of networks. Several different networks with irregular topologies are considered in order to perform a detailed study. The irregular topologies have been randomly generated.

4.3 Message Generation

For each simulation run, we have considered that message generation rate is constant and the same for all the nodes. Once the network has reached a steady state, the flit generation rate is equal to the flit reception rate(traffic). We have evaluated the full range of traffic, from low load to saturation. On the other hand, we have considered the message destination is randomly chosen among all the nodes.

4.4 Simulation Results

In this section, we show the simulation results for improved PPR scheme based on pre-order traversal of spanning tree. The simulation results are compared with existing PPR scheme. The simulation used for this work is developed with the IRFlexiSim Simulator[18]. First of all, we have discussed the way in which the path computation time is reduced by using improved PPR strategy in section 3. In order to increase the accuracy of the results, each experiment is repeated several times. The numbers of simulation runs for each topology are presented graphically. The number of data packets that are discarded during the topology change assimilation process gives an indication of the level of service a network can provide to applications. Fig. 8 compares the amount of packets that are discarded for PPR and improved PPR scheme. The results in Fig 8 shows that, for a switch removal the rate at which data packets are discarded is notably lower for new PPR scheme. The main reason is that, for improved PPR scheme minimum changes are required to update the routing tables. In case of switch additions, no packets are discarded due to inactive ports because no old roots include the switch that was just added. There is no packet discarding when a switch addition occur because it does not destroy any of the existing paths. To conclude this evaluation, Fig. 8,9 and Fig. 10 as shown below illustrates the instantaneous behavior of both the old PPR and new PPR scheme. The improved PPR scheme reduces the number of packets discarded during reconfiguration and increases the performance by distributing the traffic over all links of the network. Thus, it reduces the reconfiguration time and lowering the congestion at root node by optimize use of all links in the network.

Fig. 8 Discarded Packets versus network size

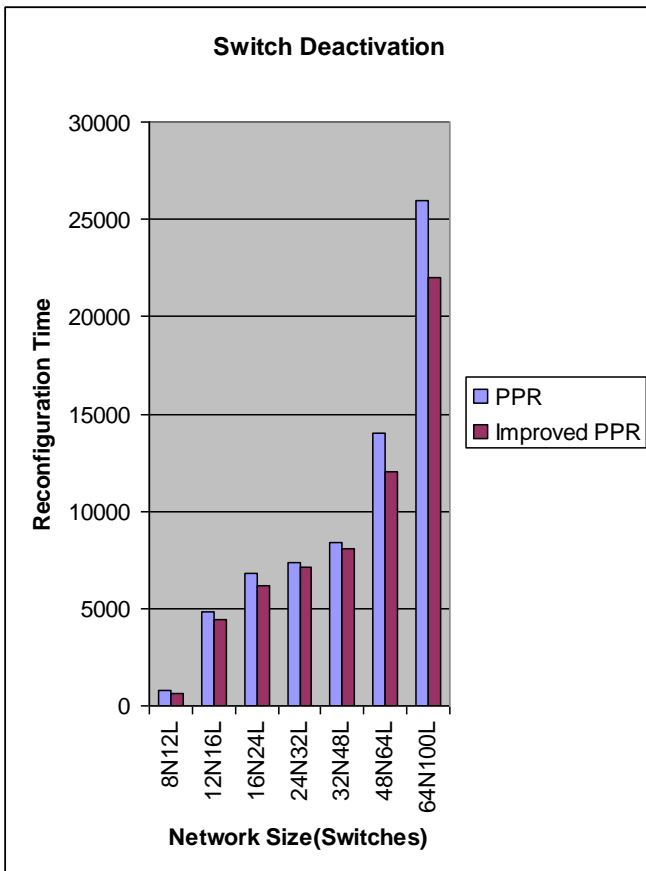
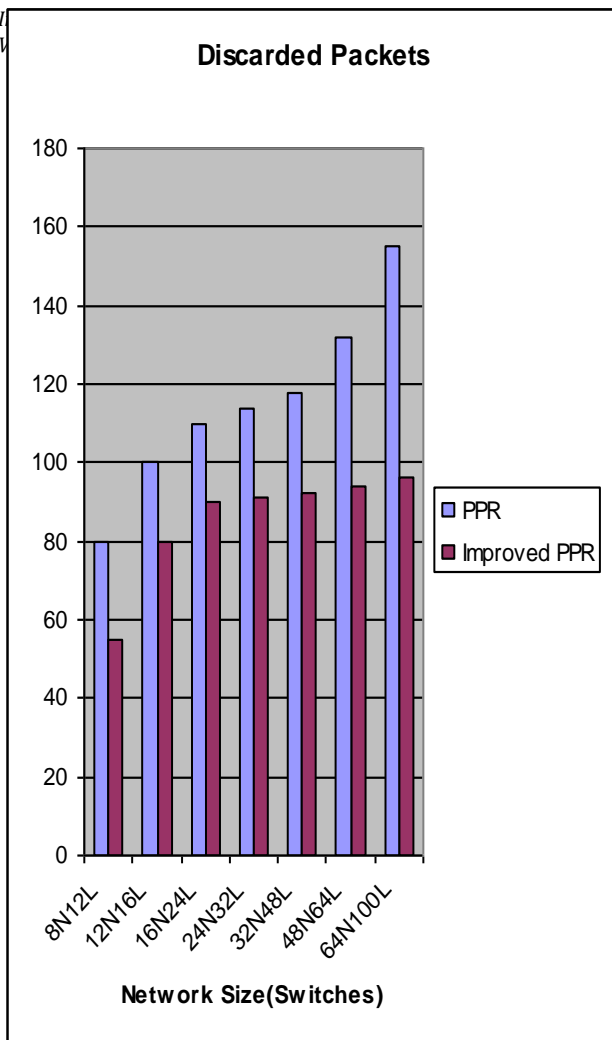

Fig. 9 Reconfiguration time versus network size

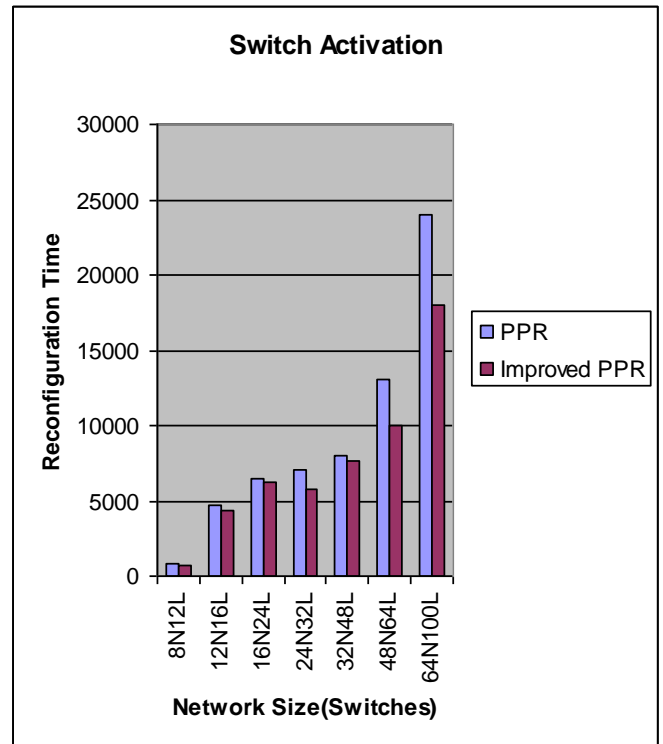

Fig. 10 Reconfiguration Time versus network size

5. CONCLUSIONS AND FUTURE WORK

In this paper, we have proposed and evaluated a simple improved reconfiguration strategy to compute the UP/DOWN routing tables. The improved methodology makes use of pre-order traversal of spanning tree in order to assign UP and DOWN directions to links is able to impose less routing restrictions to remove the cyclic channel dependencies in the network than those imposed when using the original methodology. Imposing less routing restrictions causes most messages to be routed through minimal paths and a better traffic balance, thus increasing channel utilization in the network .At a minor computational cost, the new routing function is designed to ensure that packets routed according to the old and the new routing functions can unrestrictedly coexist in the network, without the risk of forming deadlocks. Simulation results show that this significantly reduces the amount of packets that are discarded during the topology change assimilation. Moreover, our strategy does not required additional resources such as virtual channels, and it could easily be implemented in current commercial systems. As future work, we plan to extend the proposed methods in order to support other routing algorithms in addition to UP/DOWN.

References

- [1] Advanced Switching Interconnect Special Interest Group, Advanced Switching Core Architecture Specification Revision 1.0 ,December 2003, <http://www.picmg.org>
- [2] Boden, N.J., et al.: Myrinet: A gigabit per second LAN. IEEE Micro. ,February 1995
- [3] Casado, R., Bermúdez, A., Quiles, F.J., Sánchez, J.L., Duato, J.: A protocol for deadlockfree dynamic reconfiguration in high-speed local area networks. IEEE

- Transactions on Parallel and Distributed Systems 12(2), February 2001
- [4] Dally, W.J., Seitz, C.L.: Deadlock-free message routing in multiprocessor interconnection networks. IEEE Transactions on Computers 36(5), 1987
- [5] InfiniBand Architecture Specification (1.2) (November 2002)
<http://www.infinibandta.com/>
- [6] Lysne, O., Duato, J.: Fast dynamic reconfiguration in Irregular networks. In: Proc. Int. Conference on Parallel Processing, August 2000
- [7] Lysne, O., Montañana, J.M., Pinkston, T.M., Duato, J., Skeie, T., Flich, J.: Simple deadlock-free dynamic network reconfiguration. In: Proc. of the International Conference on High Performance Computing, December 2004
- [8] Myrinet, Inc.: Guide to Myrinet-, Switches and Switch Networks, 2000
<http://www.myri.com/>
- [9] R.Horst, Tnet: A reliable System area network, IEEE Micro, pp 36-44, Feb. 1995
- [10] Pinkston, T.M., Pang, R., Duato, J.: Deadlock-free dynamic reconfiguration schemes for increased network dependability. IEEE Transactions on Parallel and Distributed Systems 14(6), June 2003
- [11] Robles-Gómez, A., García, E.M., Bermúdez, A., Casado, R., Quiles, F.J.: A Model for the Development of ASI Fabric Management Protocols. In: Nagel, W.E., Walter, W.V., Lehner, W. (eds.) Euro-Par 2006. LNCS, vol. 4128. Springer, Heidelberg, 2006
- [12] Robles-Gómez, A., Bermúdez, A., Casado, R., Quiles, F.J., Skeie, T., Duato, J.: A proposal for managing ASI fabrics. Journal of System Architecture (JSA), 2008
- [13] Rodeheffer, T.L., Schroeder, M.D.: Automatic reconfiguration in Autonet. In: SRC Research Report 77 of the ACM Symposium on Operating Systems Principles, October 1991
- [14] Sancho, J.C., Robles, A., Duato, J.: A new methodology to compute deadlock-free routing tables for irregular networks. In: Proc. the 4th Workshop on Communication, Architecture, and Applications for Network-based Parallel Computing, January 2000
- [15] Schroeder, M.D., Birrell, A.D., Burrows, M., Murray, H., Needham, R.M., Rodeheffer, T.L., Satterthwaite, E.H., Thacker, C.P.: Autonet: a high-speed, self-configuring local area network using point-to-point links. IEEE Journal on Selected Areas in Communications 9(8), October 1991
- [16] NetRec[] Avresky, Dimiter(2000) Dependable Network Computing(Kluwer Academic Publishers, Dordrecht), Chapter 10.
- [17] D.R. Avresky, Y.Varoglu and M.Marinov, "Dynamically Scaling System Area Networks", IEEE Proceedings of the 12th EuroMicro Conference On Parallel, Distributed and Network-Based Processing, pp.117 – 129, Feb 2004.
- [18] <http://www.ceng.usc.edu/smart/tools.html>
- [19] Guillermo Ibanez, Alberto Garcia –Martinez, Juan A. Carral, Pedro A. Gonzalez, Arturo Azcorra, Jose M. Arco "HURP/HURBA: Zero-configuration hierarchical Up/Down routing and bridging architecture for Ethernet backbones and campus networks" Elsevier Journal of Computer Networks (54), pp. 41-56, 2010

About the Authors



Naresh Kumar received M.Tech degree in Computer Science & Engg. He is currently as Assistant Professor in the Department of university Institute Of Engineering and Technology of Kurukshetra university, Kurukshetra(India). He is currently researching in high speed networks.

Renu Vig received M.E. and Ph.D degrees in Electronics and Communication Engineering. She is presently a Professor and Director in University Institute of Engineering and Technology, Panjab University, Chandigarh (India). Her research interest includes high performance local networks, interconnection network, parallel algorithms and simulation.

Deepak bagai received M.E. and Ph.D degrees in Electronics And Communication Engineering. He is currently a Professor and Head of the Department of Electronics and Electrical Engineering Department of Punjab Engineering College(Deemed University), Chandigarh, (India). His research interest includes high speed networks, neural networks and graph theory.

Comparison Three Resource Discovery Algorithms in Grid Computing

Leyli Mohammad Khanli¹, Parisa Falahati², Shahram Babaie²

¹ University Of Tabriz, Department of Computer Science

² Islamic Azad University-Tabriz Branch, Department of Engineering
L-khanli@tabrizu.ac.ir, p.falahati87@yahoo.com, Sh.babaie@iaut.ac.ir

Abstract: Grid computing is a kind of distributed and parallel system which allows sharing and choosing heterogeneous, autonomous, and distributed resources dynamically and in execution time with criteria like efficiency, availability, cost, and quality of service. In this way, resource management and resource discovery is a basic concept in Grid computing. We should bear in mind that there are various requests in distributed systems, each of them contains different hardware and software resources; thus, it has a specific significance to identify and manage these resources in Grid computing. In this article we attempt to investigate and compare three resource discovery algorithms. Finally, we conclude that resource discovery algorithm, base on re-routing table, supports resource discovery in the shortest distance.

Keywords: resource discovery, rerouting table, grid computing, hybrid, Consecutive Resource Failure.

1. Introduction

A grid system can be described as "a large-scale, geographically distributed, hardware and software infrastructure composed of heterogeneous networked resources owned and shared by multiple administrative organizations which are coordinated to provide transparent, dependable, pervasive and consistent computing support to a wide range of application. These applications can perform distributed computing, high throughput computing, on-demand computing, data-intensive computing collaborative computing or multimedia computing" [12]. In Grid computing, there are some considerations such as efficiency, availability, cost and the quality of Service which appear important. Grid computing aims to develop an environment in which the computers could success to the resources of the other computers and use them, however in regard to the heterogeneity between computers, it is very difficult to establish this kind of structure. Dynamism is the main characteristics of the system. Power of the resource and also availability of the resources is constantly changed. A resource can easily enter and leave the system. Thus, algorithm for resource discovery in such an environment is one of the essential factors. Considering the dynamic feature of a grid system, we discuss the re-routing table algorithm which is based on routing table algorithm? In this algorithm, Grid consists of several Routers and resources in which the resources could be put

dynamically in online and offline conditions [2].

In the second section, the relevant studies concerning resource discovery in grid computing is discussed. In third section, resource discovery algorithms are being discussed. Section four compares three algorithm including re-routing table algorithm with consecutive resource failure and hybrid algorithm with each other. Section five consists of conclusion and the future works related to resource discovery.

2. Related works

There are numerous resource discovery algorithms which have been introduce in recent years, some of which are being discussed in this section. One of these algorithms is called matchmaking [6]. According to this algorithm, all categories in the system are divided in to two groups including applicant and server. All categories, requirements and features are being advertised in advertising classification. A matchmaking service is in charge of finding conformity among advertising and relevant news of categories from conformity. Similar categories are connected to each other and cooperate to perform the service.

Another approach in resource discovery is agent-based. Each agent in grid computing system is used as a representative for local resources and also cooperation with other agents to advertise and resource discovery [13].

Semantic communities [3, 4, 7, 14, 15] is another approach which has been introduced to resource discovery. The main goal in this approach is the fact that to create network communities based on similarity; the policy allows community groups to learn from each other without any central controlling. There have been suggested extra approaches in addition to the previous ones, which are the mixture of existing approaches. For example, matchmaking is combined with semantic web concept in bibliography. Asymmetrical description of resources and applications is combined with matchmaking algorithm to solve the resource discovery problem using ontology [8, 10, 11]. Routing table algorithm has been posed in [9], in this algorithm, grid consists of several Routers and resources. Every Router has a routing table so that it would be able to response to direct applications for resources. Considering the

dynamic feature of a grid system, we examine re-routing algorithm [2] and the re-routing table algorithm along with consecutive resource failure [1]

which concentrates mainly on the resources that can be turned off and are not constantly online.

3. Resource Discovery Algorithms

3.1 Re-routing Table Algorithm

In this part, we first examine resource discovery algorithm in a static environment named routing table algorithm, then we discuss resource discovery in dynamic environments named re-routing table [5]. The resource discovery algorithm in static and dynamic environments is to consider a grid system as an environment including some Routers and also some resources. Every Router consists several local resources which are controlled by the Router. In routing algorithm every Router in network maintains a routing table with the same number of different resources in the network [5]. Each category in this table represents the shortest distance measured from the Router to all of the available resources in the network by hop. Since the routing table's information about the shortest distance from each Router to all of the resources in the network, the shortest distance algorithm plays a basic role in routing tables algorithm. In this resource discovery model, an request for a particular resource in the system is given to the random Router in the network. First, the Router examine the request is satisfied by its own local resources. If there is not in the local resources, the Router sends the request to its neighbors. The trend is performed continuously until the request arrives at desired resource. In this algorithm it is assumed that the system is static, it means that all of the resources are constantly on and can not be transferred to turned off condition. Since it is the characteristic feature of a real grid environment in which the resources are freely in the system or be leave from the system, so a static resource discovery algorithm does not meet the requirement of a real system. Thus, to solve this problem, rerouting table algorithm has been proposed which controls effectively the events of extinct resource. The algorithm is described according to routing table algorithm. When a resource is turned off, if the request is for the offline resource, the algorithm tries to find another resource of the same type that is not offline.

A request is created for resource 9 in Router 11 as shown in Fig 1. The request is sent to Router 6 (has the shortest distance to resource 9 among the neighbors of Router 11), based on information in routing table shown in table 1, then it is sent to Router 7. While the resource 9 is found locally, there would be a problem that resource 9 in Router 7 is offline now and can not satisfied the request. During turning off the resource, there is an attempt to find the same type of the resource in network which is not offline for the time being so that can respond to the request. Router 5 has locally Router 9.

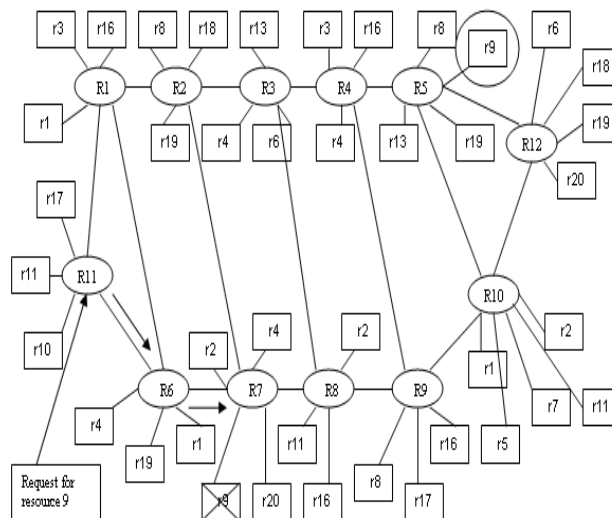

R: Router, r: resource

Figure 1: Routing for resource 9 discovery [1]

There is a problem, while a resource is turning off, the Routers in the network still take it online and consequently send the request to the same resource which is offline.

There are two algorithms to solve updating issue that have been suggested in the paper [2].

First: to update the tables, we call shortest distance algorithm for all of the Routers, which increase the computational cost of the network. The second algorithm significantly decreases the computational cost. The second algorithm: since all the Routers do not send the request for resource 9 to Router 7, so it is an extra task to update the tables for all Routers.

Table 1. Routing Table available in Routers. distance in hops from each Router to resource of type 9 [1]

Routers	resource9
1	3 hops
2	2 hops
3	3 hops
4	2 hops
5	Local
6	2 hops
7	Local
8	2 hops
9	3 hops
10	2 hops
11	3 hops
12	2 hops

To update routing tables, it is started from the Router which includes the offline resource and all of the Routers in the network are met and examined which one sends the request to offline resource to that particular Router. If the calculated hops from offline resource to the Router are equal to the distance between the Router and that type of resource in its routing table, then it is necessary for the Router to update its table. According to algorithm, the following stages will be done, beginning from Router 7 which includes the offline resource, the distance from resource 9 in Router 7 to Router 6 is equal to two hops which is the same as the distance between Router 6 and the resource in its routing table, so Router 6 sends the request for resource 9 to Router 7. whereas the distance from resource 9 in Router 7 to Router 4 is equal to 4 hops which is not the same as the distance of Router 4 to that kind of resource in its routing table that is 2 hops, and this means that Router 4 does not send the request for the resource 9 to Router 7 and instead sends it to the other Routers. Following this trend for all of the Routers in network, we conclude that routing tables of Routers 1, 3, 2, 9, 8, 6, 11 and Router 7 must be updated by turning off resource 9 in Router 7. Calling shortest distance algorithm for these Routers will result in creating re-routing tables in Table 2, Represented values for Routers 1, 3, 2, 9, 8, 6, 11 and Router 7 are different from Table 1, due to their updating. Thus, total distance in hops for request of resource 9 in Router 11, are 7 hops. Since Router 11 is completely unaware that resource 9 is offline, it has passed 2 hops and it has passed 5 hops after updating tables and sending request from Router 11 to Router 5, which has locally resource 9 in itself. Finally, re-routing table algorithm with offline resource event is as following. First, according to routing tables, the request is send to the Router which has access to the resource locally. If the sent request reaches to the Router with offline resource, it enters to the updating of routing tables phase. The phase is only started when the request for a resource encounters an offline resource. The request is sent according to re-routing tables after updating. The total distance by hop is equal to primary hops to reach Router with offline resource and the hops which it passes to reach desired resource that is not offline, using re-routing algorithm [2].

Table 2. Re-routing table for all Routers after turning down the resource 9 [1]

Routers	resource9
1	5 hops
2	4 hops
3	3 hops
4	2 hops
5	Local
6	6 hops
7	5 hops
8	4 hops
9	3 hops
10	2 hops
11	6 hops
12	2 hops

3.2 Re-routing Table Algorithm with Consecutive Resource Failure

In the environments with consecutive resource failure, there is another algorithm for resource discovery which based on re-routing table algorithm. In this algorithm, the resource discovery algorithm begins to routing from the same Router when reaches to offline resource. In Fig 2, a sample of resource failure is shown [1]. In a moment an request for resource type 4 created in Router 1. The request is sent to Router 4, which has locally resource type 5, but this resource is offline now. The updating phase in routing table suggests the request to be directed to Router 5 that has locally resource type 4. This type of resource is also offline in Router 5 too. Finally the updating phase in routing tables directs the request toward Router 6 which resource type 4 is online and available there. After two consecutive failure and passing Routers 3, 4 and 5 the request is satisfied at last. Although the consecutive failures case is rare in grid computing, it may not be ignored.

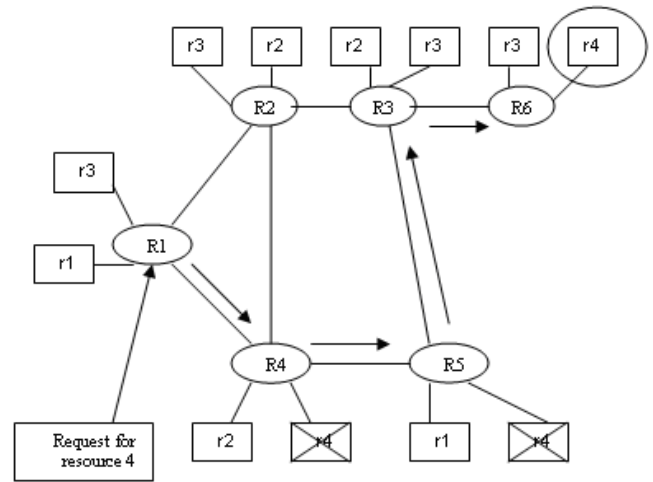

Figure 2: sample of consecutive resource failure [1]

3.3 Hybrid Resource Discovery Algorithm.

There is another algorithm for resource discovery which is called hybrid algorithm. When an request for a particular resource is created in a Router, the hybrid algorithm examines whether it is in local resources.

If the resource is not found, the request is sent to neighbors randomly. To prevent unnecessary cycles in network, the visited nodes are marked so that they will not be selected again in the future.

4. Comparison of Three Algorithms

In this section we compare the three above-mentioned algorithms. The comparison is based on hop and for 1000 requests which offline resource event is occurred once for a time unit. The represented results in this section are the average results of four different topology in grid computing consists of 20 resource type and 1002 Router [1, 2].

As it is shown in Fig 3, In the network with 1002 Router, the re-routing table algorithm is much better in this scale in comparison with hybrid algorithm. In re-routing table algorithm, the requests are available for all of the resources in the network in less than 4 hops. On one hand, in hybrid algorithm, the results are inconsistent. In this algorithm requests for all resources are between 5 to 8 hops [2]. The re-routing table algorithm with consecutive resource failure is more efficient than two other algorithms. Most of the requests for resources are between 2 to 3 hops [1], since they have the characteristics of re-routing algorithm.

On the other hand, it starts from the same Router which the offline resource event has occurred instead of starting from the main Router that the request has sent to, while encountering with offline resource, and can help to improve the hops.

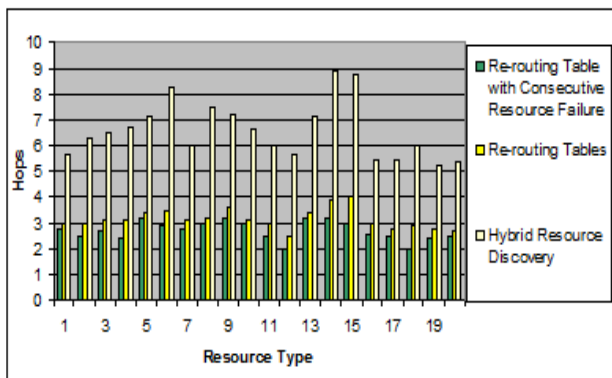

Figure 3: Comparison of three resource discovery algorithms according to hop in network with 1002 Router

5. Conclusion and the Future works

In this paper we examined re-routing table algorithm in grid computing and compared it with hybrid resource discovery algorithm. When a request is created for a resource in a Router, the routing table's algorithm takes the responsibility of resource discovery. If the resource is offline, the mentioned algorithm updates distances between those resources to all of related Routers. In comparison with hybrid algorithm, this algorithm supports resource discovery in the shortest distance, even if resource is offline.

The re-routing table algorithm with consecutive resource failure based on re-routing table algorithm, but has been improved slightly because of avoiding extra routes. We want to improve re-routing table algorithm in future so that there would be no need for passing extra hops and encountering offline resource, instead the request is sent to the Router which the requested resource is online and available in it. This algorithm may be very efficient in computational hops and resource discovery time.

References

[1] I.Karaoglanoglou,K., D.Karatza, H,2009, Performance Evaluation of a Resource Discovery Scheme in a Grid Environment Prone to Resource Failures, Aristotle University of Thessaloniki, JOURNAL OF COMPUTERS, VOL. 3, NO. 5

[2] I.Karaoglanoglou,K., D.Karatza, H, 2008, Resource Discovery in a dynamical grid based on Re-routing,Simulation Modelling Practice and Theory, Elsevier, Volume 16, Issue 6, Pages 704-720

[3] Thamarai Selvi Somasundaram, R.A. Balachandar, Vijayakumar Kandasamy, Rajkumar Buyya, Rajagopalan Raman, N. Mohanram, S. Varun, Semantic based Grid Resource Discovery and its integration with the Grid Service Broker, ADCOM 2006: in: Proceedings of 14th International Conference on Advanced Computing & Communications (2006), pp.84-89

[4] Hongsuda Tangmurarunkit, Stefan Decker, Carl Kesselman, Ontology-based resource matching in the grid – the grid meets the Semantic Web, in: International Semantic Web Conference, 2003.

[5] Li,J.,Vuong,S,2005,A Scalable Semantec Routing Architecture for Grid Resource Discovery,Computer Science Department,University of British Columbia, IEEE Computer Society

[6] Juan Li, Son Vuong, Semantic overlay network for Grid Resource Discovery, in: Grid Computing Workshop, 2005.

[7] Junwei Cao, Stephan Jarvis, Subhash Saini, and Darren Kerbyson and Graham Nudd, "ARMS: An agent-based resource management system for Grid Computing", Scientific Programming, Special Issue on Grid Computing, 10(2), 135-148, 2002

[8] A.C. Vidal, J.R. Braga, J.F. Kon, S.T. Kofuji, Defining and exploring a grid system ontology, in: Proceedings of the 4th International Workshop on Middleware for Grid Computing, ACM Press, New York, NY, USA, 2006, p. 16.

[9] R. Raman, M. Livny, M. Solomon, Matchmaking: distributed resource management for high throughput computing, hpdc, in: Seventh IEEE International Symposium on High Performance Distributed Computing (HPDC-7'98), 1998, p. 140.

[10] Bote-Lorenzo,M.,Dimitriadis,Y.,Gomez-Sanchez, E., 2004. Grid characteristics and uses: a grid definition. In Postproc. Of the First European Across Grids Conference(ACG1/203), LNCS 2970,pages 291-298,Santiago de compostela, Spain,Februry, Springer-verlag.

[11]S. Castano, A. Ferrara, S. Montanelli, G. Racca, Matching techniques for resource discovery in distributed systems using heterogeneous ontology descriptions, in: Proceedings of the International Conference on Information Technology: Coding and Computing (ITCC'04), 2004.

[12]Li,W., Xu,Z., hang,J.,Fangpeng,D,2002,Grid Resource Discovery based on a Routing-Trransferring Model, Proceeding of Third International Workshop on Grid Computing: GRID 2002, Baltimore, MD. , Springer, 2002,pp. 145-156.

[13]Fawad Nazir, Hazif Farooq Ahmad, Hamid Abbas Burki, Tallat Hussain Tarar, Arshad Ali, Hiroki Suguri, A resource monitoring and management middleware infrastructure for Semantic Resource Grid, SAG 2004, LNCS, vol. 3458, 2005, pp. 188–196

[14]Juan Li, Son Vuong, Grid resource discovery using semantic communities, in: Proceedings of the 4th International Conference on Grid and Cooperative Computing, Beijing, China, November, 2005.

[15]Cheng Zhu, Zhong Liu, Weiming Zhang, Weidong Xiao, Zhenning Xu, Dongsheng Yang, Decentralized Grid Resource Discovery based on Resource Information Community, Journal of Grid Computing (2005).

Development Strategies for e-LMSs

Vibha Ojha ¹, Neha Sharma ², Anand Sharma ³, Sandesh Jain ⁴

¹ Govt. Engg. College, Ajmer, Rajasthan
vibha.ojha@gmail.com

² Keen college, Bikaner, Rajasthan
naish_neha@yahoo.com

³ MITS, Lakshmanagarh, Sikar, Rajasthan
anand_glee@yahoo.co.in

⁴ CDAC, Hyderabad, A.P.
sandeshj@cdac.in

Abstract: The growing interest in e-learning seems to be coming from several directions. These include organizations that have traditionally offered distance education programs either in a single, dual or mixed mode setting. They see the incorporation of online learning in their repertoire as a logical extension of their distance education activities. The corporate sector, on the other hand, is interested in e-learning as a way of rationalizing the costs of their in-house staff training activities. E-learning is of interest to residential campus-based educational organizations as well. The e-Learning management system is “the operating system” for e-learning in the enterprise. At a minimum, it automates the administration of training events: handling course schedules and registrations; delivering learning content; facilitating communication among learners and between learners and instructors; and tracking and reporting on learners’ progress and test scores. It is designed to handle courses from multiple providers. In this paper we are considering the e-learning management system development strategies.

Keywords: E-learning, e-learning management system, e-learning products, production

1. Introduction

e-Learning is commonly referred to the intentional use of networked information and communications technology in teaching and learning. A number of other terms are also used to describe this mode of teaching and learning. They include *online learning*, *virtual learning*, *distributed learning*, *network* and *webbased learning*. Fundamentally, they all refer to educational processes that utilize information and communications technology to mediate asynchronous as well as synchronous learning and teaching activities. On closer scrutiny, however, it will be clear that these labels refer to slightly different educational processes and as such they cannot be used synonymously with the term *e-learning*. As the letter “e” in e-learning stands for the word “electronic”, e-learning would incorporate all educational activities that are carried out by

individuals or groups working online or offline, and synchronously or asynchronously via networked or standalone computers and other electronic devices.

A key attribute of information and communications technology is its ability to enable flexible access to information and resources. Flexible access refers to access and use of information and resources at a time, place and pace that is suitable and convenient to individual learners rather than the teacher and/or the educational organization.

Access to information and communications technology changed all that as it offered a range of possibilities for capturing and delivering all types of subject matter content to learners and teachers in distributed educational settings. This meant access to subject matter content and learning resources via networked information and communications technologies across a range of settings such as conventional classrooms, workplaces, homes, and various forms of community centers. Contemporary educational institutions, including conventional distance education providers, often pride themselves in being able to meet the learning needs of their students and staff at a time, place and pace that is most convenient to them.

The reference to Bloom's taxonomy will help detail the process lesson by lesson and analyze the course in terms of competences as follows that will look more or less like this :

- **Knowledge:**
Recall data or information.
- **Comprehension:**
Understand the meaning, translation, interpolation, and interpretation of instructions and problems. State a problem in one's own words.
- **Application:**
Use a concept in a new situation or unprompted use of an abstraction. Applies

what was learned in the classroom into novel situations in the work place.

- **Analysis:**
Separates material or concepts into component parts so that its organizational structure may be understood. Distinguishes between facts and inferences.
- **Synthesis:**
Builds a structure or pattern from diverse elements. Put parts together to form a whole, with emphasis on creating a new meaning or structure.
- **Evaluation:**
Make judgments about the value of ideas or materials.

e-Learning may also comprise combinations of the foregoing types of activities. It is growing in popularity in all areas and levels of education and training. E-learning affords opportunities to design learning environments that are authentic, situated in the learning context, and also problem-based in order to provide students with "learning by doing" experiences. E-learning can manifest itself in four different ways:

- Individualized self-paced e-learning online,
- Individualized self-paced e-learning offline,
- Group-based e-learning synchronously and
- Group-based e-learning asynchronously.

e-Learning has not developed in a vacuum. Many of the models of e-learning currently being delivered largely replicate traditional classroom models. The e-learning tools are used to replace one or more elements of the classroom teacher's role of content provider, interactive help and learning support, and student management/administration. However, the power of computing, the Internet and database technologies are now making it possible to develop other models such as:

- complex immersive learning environments and simulations
- open-ended, constructivist models; driven by the learners' own needs, interests, and motivations
- knowledge management-based systems where learners are able to locate and access resources to resolve particular issues or problems when and where required ("just-in-time" learning).

2. e-Learning Management Systems

e-LMSs are a suite of software tools that enable the management and facilitation of a range of learning and teaching activities and services. In large-scale operations, e-learning management systems can save costs and time. In conventional educational settings, e-learning management systems can help

to improve the speed and effectiveness of the educational processes, communication among learners, and also staff and students. Most e-learning management systems also incorporate a learning content management system (LCMS), which is a set of software tools that enables the storage, use and reuse of the subject matter content. Contemporary organizations recognize that the use of e-learning management systems have the potential to significantly improve their image and value, as well as access to their services. e-Learning products and services embrace a range of features:

- Online content and resources (sometimes called learningware) that can range from traditional text, audio, and video to media-rich, interactive applications;
- Communication tools to support synchronous and/or asynchronous interaction between the teacher and the learner or between learners;
- Assessment tools;
- Navigation structures to guide learners;
- Research opportunities and links to enhance the learning;
- Annotations to enable the learner to record and consolidate learning.

It is likely that the next generation of e-LMSs will have additional features such as better collaborative learning tools and better integration with other complementary systems, and with portable and wireless (mobile-learning) devices. It is also suggested that the next generation of e-LMSs is going to be increasingly browser-based and less reliant on umpteen downloads or plug-ins on the user's desktop. They will have to be easier-to-use, more robust, scalable and more easily customizable. With the growing interest in the sharing of study materials, they are also likely to comply more with industry standards and with complementary systems.

3. Development of e-LMSs

In this section we are going to explain the strategies for developing the e-LMSs. From a developer's perspective, the traditional evaluation of learning resources cannot be separated from the difficulties and complexities arising from the features described above. In particular:

- Evaluation of e-learning resources frequently occurs without taking into account contextual and cultural factors.
- In a rapidly changing and not clearly understood environment (both technologically and educationally), established standards for the design and development of resources and related criteria for their evaluation are not stable (even where they do exist). This can lead to subsequent evaluation of factors that

were not part of the general thinking at the time of development.

- Development of good e-learning products is an expensive process and often the compromises needed as a result of limited budgets or organizational limitations are not well documented. Evaluation often occurs without consideration of these compromises and therefore potentially valuable evaluation data are lost.

The major components in the design and development of e-learning products and the major contextual factors should be considered together in any evaluation of the products.

To get started with an e-Learning project, the organization should check if it can rely on the 4 C minimal requirements :

- **Connectivity** Will the IT infrastructure guarantee the project to happen in acceptable conditions
- **Competences** Will we provide the expected and relevant courses, tests, activities and assessment protocol?
- **Capability** Are all the actors of the system able to enter the project
- **Culture** Are all the actors of the system eager to enter the project

A common practice is to work during the first 6 months on a pilot project so as to get familiar with the e-learning project management methodology and go through all its phases to get familiar with the *Strengths, Weaknesses, Opportunities and Threats* of e-Learning. During this phase, the core team should go through the 4 phases of e-Learning project management: **Analysis** (see what we need), **Design** (decide how to do things), **Development** (create courses and associated media), **Interaction** (give courses, coach and assess trainees).

3.1 Production

Traditional development processes have followed a linear, sequential approach to development and production. Such approaches are relatively inflexible and time-consuming. More sophisticated approaches recognize that each of the techniques and skills associated with design and development has a continuing influence throughout the project. This approach requires an effective team-based operation. The approach is based on:

- recognition of specialist roles in the design and production process;
- recognition that each of these roles informs all aspects of design and production;
- shared risks and responsibilities; and
- A production environment that is innovative, creative, and trusting.

The specialist roles required for the team can vary significantly depending on the nature and complexity of the product. However those roles may include:

- project manager;
- creative director;
- instructional designer;
- subject matter experts;
- screen designer;
- programmer;
- video, audio, and graphics specialist;
- Web master; and
- database designer, animation artist, etc.

3.2 Multimedia authoring tools

To analyse, design, develop, give and follow e-courses, the organization will need a series of IT software. It will be completed in particular with a series of multimedia authoring tools. Here is a first list of tools that one may want to choose from.

- **Project management :**
Organizing the training team
- **Image manipulation :**
Resizing and manipulating photos and screenshots
- **Audio manipulation :**
Recording and editing .mp3 audio
- **Desktop animation :**
Creating software demonstrations and animated diagrams.
- **Learning path authoring :**
Creating course sequences

3.3 E-Learning project management dashboard

To manage a large scale e-Learning project, the organization might want to start by summarizing the decisions in a three-levels spreadsheet :

- E-Learning Project sheet in terms of Analysis, Design, Development, Interaction
- Course scenario sheet in terms of Pre-requisites, Week-by week agenda, Assessment protocol and team casting
- Lesson storyboard sheet

4. Conclusion

It is crucial to have processes in place for knowing how you are doing with what you have initiated. This will include how your staff and students are engaging in e-learning. Without this kind of evidence, you are in no position to know how you might be traveling and what changes and/or improvements are necessary. Evaluation of the impacts of your processes should be closely integrated into the planning and implementation of any e-learning activity. The growth of e-learning is directly related to the increasing access to information and communications technology, as well its decreasing cost. The capacity of information and communications technology to support multimedia resource-based learning and teaching is also relevant to the growing interest in e-learning.

Furthermore, e-LMSs are neither a cheap nor an easy educational option. It does not offer a quick fix for problems associated with dwindling enrollments, distance education, or poor teaching and learning. Lack of careful planning and implementation of e-LMSs can actually lead to decreasing standards and morale, poor performance in learning and teaching, and wasted resources and loss of revenue.

Conference on Computer, Electrical, and Systems Science, and Engineering (CESSE), 2007 WASET.ORG, ISBN 978-975-01752-0-6, V-21, 19
[11] <http://www.dokeos.com/doc/thirdparty/ScormBestPracticesContentDev.p>

References

- [1] Hmelo, C. E., Holton, D. L., & Kolodner, J. L. (2000). Designing to learn about complex tasks. *The Journal of the Learning Sciences*, 9(3), 243-246.
- [2] Zenger, J., Uehlein, C. *Why Blended Will Win*, T+D (formerly Training and Development Magazine), ASTD, August 2001, pg. 57
- [3] IEEE (2003). Learning Technologies Standards Committee WG12: Learning object metadata. Accessed September , 2005 from : <http://ltsc.ieee.org/wg12/>.
- [4] Romiszowski, A. (2004). How's the e-learning baby? Factors leading to success or failure of an educational technology innovation, *Educational Technology*, 44(1), January-February, 5-27
- [5] Carrol, J. M., & Rosson, M. B. (2005). Toward even more authentic casebased learning. *Educational Technology*, November / December, 45(6), 5-11.
- [6] Willems, J. (2005). Flexible learning: Implications of "when-ever", "where ever" and "what-ever". *Distance Education*, 26(3), 429-435.
- [7] Gefen, D., & Straub, D. (2005). A practical guide to factorial validity using PLS-Graph: Tutorial and annotated example. *Communications of the Association for Information Systems*, 16, 91-109.
- [8] Varlamis, I. & Apostolakis, I. (2006). The present and future of standards for e-learning technologies, *Interdisciplinary Journal of Knowledge and Learning Objects*, 2, 59-76.
- [9] Georgouli, K., Kantzavelou, I., Guerreiro, P., & Koilias, C. (2006). Enhancing Student Learning Using Asynchronous e-Learning Platforms. *Proceedings of the International Conference on Cognition and Explanatory Learning in Digital Age (CELDA 2006)*, Lisbon: IADIS, 73-80.
- [10] Kalinga E. A., Bagile B. B. R, and Lena Trojer L., (2007), " An Interactive e-Learning Management System (e-LMS): A Solution to Tanzanian Secondary Schools' Education", XXI. International

Model Order Reduction Using Bio-inspired PSO and BFO Soft -Computing for Comparative Study

Sudhir Y Kumar¹, PK.Ghosh² and S Mukherjee³

^{1,2} Faculty of Engineering and Technology, Mody Institute of Technology and Science
Lakshmangarh, Dist Sikar (Rajasthan), India 332311

³ Department of Electrical Engineering, Indian Institute of Technology
Roorkee, Uttrakhand, India

Corresponding author Email ID: skumar_icfai@yahoo.co.in

Abstract: The authors proposes here a method for model order reduction of linear time invariant(LTI) dynamic system using two bio-inspired computational techniques, namely, Particle Swarm Optimization (PSO) and Bacterial Foraging Optimization (BFO). The numerator and denominator polynomial of the reduced order model of high order linear dynamic system are computed by minimizing the integral square error between the original high order and reduced order system using PSO and BFO. The two approaches find a solution to a given objective function employing different procedures and computational techniques; as a result their performance can be evaluated and compared. The problem area chosen is that of reduced order system modeling used in control systems engineering. Particle Swarm Optimization and Bacterial Foraging Optimization algorithm obtains a better lower order approximant that reflect the characteristics of the original higher order system and the performance evaluated using these methods are compared. Integral square error is used as an indicator for selecting the lower order model. The proposed method guarantees stability of the reduced order model, if the original high order system is stable. The method is illustrated with the help of an example using Mat lab 2010 environment.

Keywords: Model Order Reduction, Stability, Particle Swarm Optimization, Bacterial Foraging Optimization and Integral Square Error

1. Introduction

The modeling of complex dynamic systems is one of the most important subjects in engineering and Science. A model is often too complicated to be used in real life problems. So approximation procedures based on physical considerations or mathematical approaches are used to achieve simpler models than the original one. The subject of model order reduction is very important to engineers and scientists working in many fields of engineering, especially, for those who work in the process control area . In control engineering field, model reduction techniques are fundamental for the design of controllers where numerically complicated procedures are involved. This would provide the designer with low order controllers that may have less hardware requirements. Efforts towards obtaining low-order models from

high-degree systems are related to the aims of deriving stable reduced-order models from stable original ones and ensuring that the reduced-order model matches some quantities of the original one. Numerous methods are available in the literature for order-reduction of linear continuous systems in time domain as well as in frequency domain [1]-[7]. Further, the extension of single-input single-output methods to reduce multi input multi-output systems has also been carried out in [8]-[11]. Each of these methods has both advantages and disadvantages. In spite of several methods available, no single approach always gives the best results for all systems.

The stability equation method is also one of the popular techniques among the various model order reduction methods available in the literature [12]. This method preserves stability in the reduced model, if the original high-order system is stable, and retains the first two time-moments of the system, thus ensuring steady-state response matching for impulse and step inputs between the original high-order system and the reduced order model. Some interesting variants on the basic technique have also appeared in the literature [13]-[14], which shows that the stability equation approach may be applied to non-minimum phase [13] and oscillatory systems [14]. This method was also combined with Pade approximation method by Chen et al. [15] and in order to overcome the drawback of approximating the non-dominant poles of the original system, an improved method for Pade approximants using the stability equation method was proposed by Pal [16]. Parthasarathy et al. combined this method with modified Caueer continued fraction technique in order to retain the rank of the high-order system in the reduced order model [17].

Further, numerous methods of order reduction are also available in the literature [18]-[22], which are based on the minimization of the integral square error (ISE) criterion. However, a common feature in these methods is that the values of the denominator coefficients of the low order system (LOS) are chosen arbitrarily by some stability preserving methods such as dominant pole, Routh approximation methods, etc. and then the numerator coefficients of the LOS are determined by minimization of the ISE. Hewitt and

Luss [23] suggested a technique, in which both the numerator and denominator coefficients are considered to be free parameters and are chosen to minimize the ISE in impulse or step responses.

Recently, bio-inspired based Particle Swarm Optimization (PSO) technique appeared as a promising algorithm for handling the optimization problems. Particle swarm optimization (PSO) is a population based stochastic optimization technique developed by Eberhart and Kennedy [24] in 1995, inspired by social behavior of bird flocking or fish schooling. The PSO method is a member of the wide category of Swarm Intelligence methods. PSO shares many similarities with evolutionary computation techniques such as Genetic Algorithms (GA). The system is initialized with a population of random solutions and searches for optima by updating generations.

Further, a new nature -inspired computation technique, namely bacterial foraging (BF) optimization, has been proposed [25-26]. In this approach, the foraging behavior of *E. coli* bacteria, including locating, handling, and ingesting food, is mimicked. They can be classified as four stages such as chemotaxis, swarming, reproduction, and elimination and dispersal, which are modeled to tackle optimization problems.

In this paper, Particle Swarm Optimization and Bacterial foraging optimization techniques are used independently to higher order systems and a suitable lower order system is modeled and compared using integral square error (ISE). The organization of the paper is as follows: Section 2 discusses the problem statements. Particle Swarm Optimization and Bacterial Foraging Algorithms with their flow-charts are given in section 3. Results and discussions are discussed in section 4 with numerical examples on Matlab 2010 platform. Finally, we conclude in section 5.

2. Statement of the Problem:

Let an n^{th} order linear time invariant system with q inputs and r outputs described in time domain by state space equations as,

$$\begin{aligned} \dot{x} &= Ax(t) + Bu(t) \\ y(t) &= Cx(t) \end{aligned} \quad (1)$$

where, \dot{x} is n dimensional state vector, u is q dimensional control vector and y is r dimensional output vector with $q \leq n$ and $r \leq n$. Also, A in $n \times n$ system matrix, B is $n \times q$ input matrix and C is $r \times n$ output matrix.

Alternatively, equation (1) can be described in frequency domain by the transfer function matrix of order $r \times q$ as,

$$G(s) = \frac{N(s)}{D(s)} = \frac{\sum_{i=0}^{n-1} A_i s^i}{\sum_{i=0}^n a_i s^i} \quad (2)$$

where, $N(s)$ is the numerator polynomial and $D(s)$ is the common denominator polynomial of the higher order system. Also, A_i and a_i are the constant matrices of numerator and denominator polynomial respectively.

Irrespective of the form represented in equation (1) or (2) of the original system $G(s)$, the problem is to find an m^{th} lower order model $R^m(s)$, where $m < n$ in the following form represented by equation (3), such that the reduced model retains the important characteristics of the original system and approximates its response as closely as possible for the same type of inputs with minimum integral square error.

$$R^m(s) = \frac{N^m(s)}{D^m(s)} = \frac{\sum_{i=0}^{m-1} B_i s^i}{\sum_{i=0}^m b_i s^i} \quad (3)$$

where, $N^m(s)$ and $D^m(s)$ are the numerator matrix polynomial and common denominator of the reduced order model respectively. Also, B_i and b_i are the constant matrices of numerator and denominator polynomial of the same order respectively.

The integral square error (ISE) is considered as objective function/fitness can be expressed as

$$J = \int_0^{\infty} (Y_t - y_t)^2 dt \quad (4)$$

where, Y_t is the unit step time response of the given higher order system at the t^{th} instant in the time interval $0 \leq t \leq \infty$ and y_t is the unit step time response of the lower order system at the t^{th} time instant.

The objective is to model a system $R^m(s)$, which closely approximates $G(s)$ for a specified set of inputs (step & impulse).

3. Bio- Inspired Algorithms

3.1 Particle Swarm Optimization- An Overview.

PSO is an evolutionary computation technique developed by Eberhart and Kennedy [24] in 1995, which was inspired by the Social behavior of Bird flocking and fish schooling. PSO has its roots in artificial life and social psychology as well as in Engineering and Computer sciences. It is not largely affected by the size and non- linearity of the problem and can converge to the optimal solution in many problems where most analytical methods fail to converge.

Particle Swarm Optimization has more advantages over Genetic Algorithm as follows: PSO is easier to implement and has fewer parameters to adjust. Every particle in PSO remembers its own previous best value as well as the neighborhood best.

PSO utilizes a population of particles that fly through the problem space with given velocities. Each particle has a memory and it is capable of remembering the best position in the search space ever visited by it. The Positions corresponding to the Best fitness is called *Pbest* (also called local best) and the global best out of all the particles in the population is called *gbest*.

At each iteration, the velocities of the individual particles are updated according to the best position for the particle itself and the neighborhood best position.

The velocity of each agent can be modified by the following iterative equation:

$$V_i^{k+1} = W.V_i^k + C_1 R_1 . (p_{besti} - S_i^k) + C_2 R_2 (g_{best} - S_i^k) \quad (5)$$

where, V_i^k = Velocity of agent i at iteration k.

W = Weighting Function

C_1 and C_2 = acceleration/weighting factor.

R_1 & R_2 = random number between 0 and 1.

S_i^k = Current position of agent i at k^{th} iteration.

$P_{best\ i}$ = Pbest of agent i.

g_{best} = gbest of the group.

The current position can be modified by the equation

$$S_i^{k+1} = S_i^k + V_i^{k+1} \quad (6)$$

The flowchart of the PSO algorithm is shown in Fig.1.

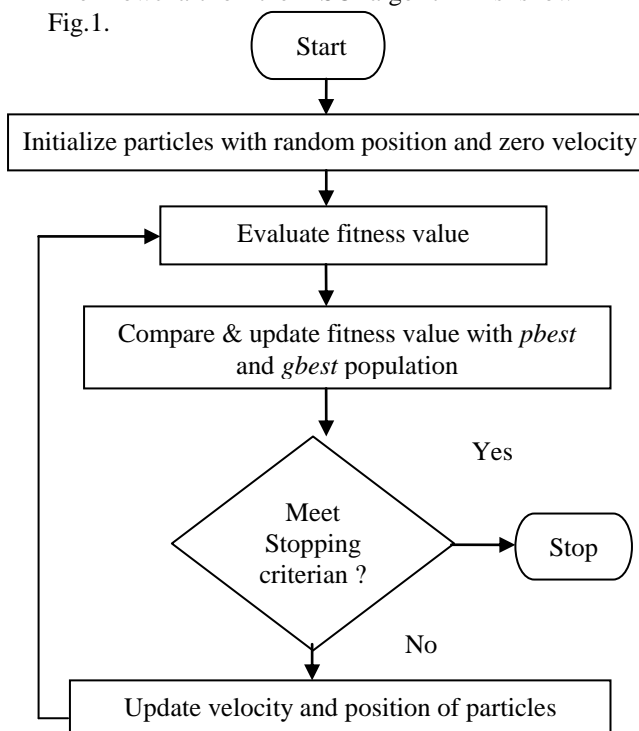

Figure 1: Flowchart of PSO Algorithm

The Algorithmic steps involved in Particle Swarm Optimization Algorithm are as follows:

Step 1: Select the relevant parameters of PSO.

Step 2: Initialize a Population of particles with random Positions and Velocities in the problem space.

Step 3: Evaluate the desired Optimization fitness Function for each particle.

Step 4: For each Individual particle, compare the Particles fitness value with its P_{best} . If the Current value is better than the P_{best} value, then update P_{best} for agent i.

Step 5: Identify the particle that has the best fitness Value. The value of its fitness function is identified a g_{best} .

Step 6: Compute the new Velocities and Positions of the particles according to equations (5) & (6).

Step 7: Repeat steps 3-6 until the stopping Criterion of Maximum Generations is met.

3.2 Bacterial Foraging Optimization- An Overview.

It depends upon the fitness criteria of the bacteria, which relies upon their food searching and motile behavior. The law of evolution supports those species who have better food searching ability and either eliminates or reshapes those with poor search ability. The stronger genes of those species gets propagated in the evolution chain since they possess ability to reproduce even better species in future generations. So a clear understanding and modeling of foraging behavior in any of the evolutionary species, leads to its application in many non-linear system optimization algorithm. The foraging strategy of *E. coli* bacteria present in human intestine can be explained by four processes namely Chemotaxis, Swarming, Reproduction, Elimination and Dispersal.

Chemotaxis: The characteristics of movement of bacteria in search of food can be defined in two ways, i.e. swimming and tumbling together know as chemotaxis. A bacterium is said to be 'swimming' if it moves in a predefined direction, and 'tumbling' if moving in an altogether different direction. Mathematically, tumble of any bacterium can be represented by a unit length of random direction φ (j) multiplied by step length of that bacterium $C(i)$. In case of Swimming this random length is predefined.

Swarming: For the bacteria to reach at the richest food location it is desired that the optimum bacterium till a point of time in the search period should try to attract other bacteria so that together they converge at the desired location more rapidly. We can resemble the best food location as the convergent solution point of the algorithm.

Reproduction: The original set of bacteria, after getting evolved through several chemotactic stages

reach the reproduction stage. Here best set of bacteria get divided into two groups. The healthier half replaces the other half of bacteria, which gets eliminated, owing to their poorer foraging abilities. This makes the population of bacteria constant in the evolution process.

Elimination and Dispersal: In the evolution process a sudden unforeseen event can occur, which may drastically alter the smooth process of evolution and cause the removal of the set of bacteria and/or disperse them to a new environment. Instead of disturbing the usual chemotactic growth of the set of bacteria, this unknown event may place a newer set of bacteria nearer to the food location. From a broad perspective, elimination and dispersal are parts of the population-level long-distance motile behavior. In its application to optimization it helps in reducing the behavior of *stagnation*, (i.e. being trapped in a premature solution point or local optima).

The mathematical derivations and theoretical aspect of this new concept are presented in [25-26]. This technique can optimize the coefficients of reduced order model. The algorithm of the Bacterial Foraging Optimization is as follows:

Step1-Initialization of parameters

p : Number of parameters to be optimized.

S : Number of bacteria to be used for searching the total region.

N_s : Swimming length after which tumbling of bacteria will be under taken in a chemotactic loop.

N_c :The number of iteration to be under taken in a chemotactic loop. ($N_c > N_s$).

N_{re} : The maximum number of reproduction to be under taken.

N_{ed} : the maximum number of elimination and dispersal events imposed over the bacteria.

P_{ed} : the probability with which the elimination and dispersal will continue.

The location of each bacterium $P(1-p, 1-S, 1)$ is specified by random numbers on $[-1, 1]$. The value of $C(i)$ which is assumed to be constant in our case for all the bacteria to simplify the design strategy.

Step-2 Iterative algorithm for optimization

This section models the bacterial population chemotaxis, swarming, reproduction, elimination and dispersal (initially,

$j=k=l=0$). For the algorithm updating θ^i automatically results in updating of 'p'.

1) Elimination-dispersal loop: $l=l+1$

2) Reproduction loop: $k=k+1$

3) Chemotaxis loop: $j=j+1$

a) **For** $i = 1, 2, \dots, S$, calculate objective/fitness function value for each bacterium i as follows.

- Compute value of objective function $J(i, j, k, l)$. Let

$$J_{sw}(i, j, k, l) = J(i, j, k, l) + J_{cc}(\theta^i(j, k, l), P(j, k, l))$$

(i.e., add on the cell to-cell attractant effect for swarming behavior).

- Let $J_{last} = J_{sw}(i, j, k, l)$ to save this value since we may find a better fitness via a run.
- **End** of For loop

b) For $I = 1, 2, \dots, S$ take the tumbling/swimming decision

- Tumble: Generate a random vector $\Delta(i) \in R^p$ with each element $\Delta_m(i)$ $m = 1, 2, \dots, p$, a random number on $[-1, 1]$.
- Move: Let

$$\theta^i(j+1, k, l) = \theta(j, k, l) + C(i) \frac{\Delta(i)}{\sqrt{\Delta^T(i)\Delta(i)}}$$

Fixed step size in the direction of tumble for bacterium

i is considered.

- Compute $J(i, j+1, k, l)$ and then let $J_{sw}(i, j+1, k, l) =$

$$J(i, j+1, k, l) + J_{cc}(\theta^i(j+1, k, l), P(j+1, k, l))$$

- Swim :

i) Let $m = 0$; (counter for swim length)

ii) While $m < N_s$ (have not climbed down too long)

- Let $m=m+1$
- If $J_{sw}(i, j+1, k, l) < J_{last}$ (if doing better),

let $J_{last} = J_{sw}(i, j+1, k, l)$ and let

$$\theta^i(j+1, k, l) = \theta(j+1, k, l) + C(i) \frac{\Delta(i)}{\sqrt{\Delta^T(i)\Delta(i)}}$$

and use this $\theta^i(j+1, k, l)$ to compute the new $J(i, j+1, k, l)$

- Else, let $m = N_s$. This is the end of the while statement.

c) Go to next bacterium ($i+1$) if $i \neq S$ (i.e. go to b) to process the next bacterium.

4) If $j < N_c$, go to step 3. In this case, continue chemotaxis since the life of the bacteria is not over.

5) Reproduction:

a) For the given k and l , and for each $i = 1, 2, \dots, S$, let

$$J^i_{health} = \min_{j \in \{1 \dots N_c\}} [J_{sw}(i, j, k, l)]$$

be the health of bacterium i (a measure of how many nutrients it got over its life time and how successful it was at avoiding noxious substance). Sort bacteria in order of ascending cost J_{health} (higher cost means lower health).

b) The $S_r = S/2$ bacteria with highest J_{health} values die and other S_r bacteria with the best value split (and the copies that are made are placed at the same location as their parent)

6) If $k < N_{re}$ go to 2, in this case, we have not reached the number of specified reproduction steps, so we start the next generation in the chemotactic loop.

7) Elimination-dispersal: For $i = 1, 2, \dots, S$, with probability P_{ed} , eliminate and disperse each bacterium (this keeps the number of bacteria in the population

constant) to a random location on the optimization domain.

The flowchart of the above algorithm is shown in Fig. 2.

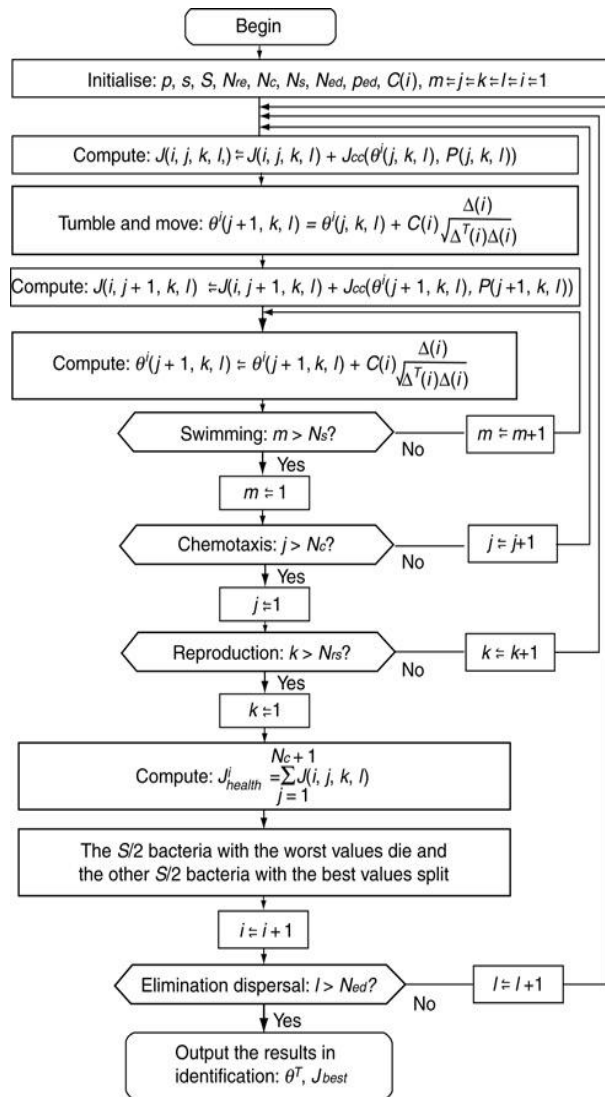

Figure 2: Flowchart of BFO Algorithm

4. Numerical Example And Results

The simulations were carried out on a Pentium IV, 3 GHz computer in the MATLAB 2010 Environment. The flowchart describing the entire reduced order model using PSO and BFO methods are shown in Figs. 1 and 2, respectively.

A numerical example is chosen from literature for comparison of the resulting reduced order system with the original high order system. An ISE error index J (objective function) between the transient parts of original higher order response and the proposed reduced order response is calculated to measure the closeness of $R(s)$ to $G(s)$.

Table 1: Typical Parameters Used by the PSO

Type of variable	Value
Swarm Size	40
Max. Generations	100
C_1, C_2	2.0, 2.0
w_{start}, w_{end}	0.6, 0.3

Table 2: Typical Parameters Used by the BFO

Type of variable	Value
S	8
p	1
Nc	5
Ns	3
Nre	8
Ned	3
ped	0.25

Let us consider an eighth-order system [21] described by the transfer function:

$$G_8(s) = [N(s) / D(s)] \quad (7)$$

where,

$$N(s) = 18s^7 + 514s^6 + 5982s^5 + 36380s^4 + 122664s^3 + 222088s^2 + 185760s + 40320$$

$$D(s) = s^8 + 36s^7 + 546s^6 + 4536s^5 + 22449s^4 + 67284s^3 + 118124s^2 + 109584s + 40320$$

The transient and steady state gains for the given $G(s)$ are calculated as

$$G(s) \Big|_{transient} = \frac{18}{1} = 18; G(s) \Big|_{steady-state} = \frac{40320}{40320} = 1 \quad (8)$$

An auxiliary scheme as in Appendix is used to obtain the transfer function $R(s)$ of a basic reduced order model from the given $G(s)$. The coefficients of $R(s)$ are used as initial seed values for training in PSO and BFO techniques. Following the auxiliary scheme, the transfer function of the basic lower order model is given by

$$R(s) = \frac{185760s + 40320}{118124s^2 + 109584s + 40320} \quad (9)$$

The above equation is scaled and tuned to satisfy the transient gain and steady-state gain as defined in Eq. (8). In doing so, $R(s)$ becomes

$$R(s) = \frac{18s + 3.9069}{s^2 + 0.9277s + 0.3413} = \frac{B_1s + B_0}{b_2s^2 + b_1s + b_0} \quad (10)$$

The algorithms had to find the parameters B_0 , b_1 and b_0 . The proposed parameters ($B_0 = 3.9069$, $b_1 = 0.9277$, $b_0 = 0.3413$) are used as initial seed values for tuning in PSO and BFO with the condition that the objective function ISE to be minimized. For getting convergent simulation results, we take the parameters as given in table 1 and table 2 for PSO and BFO algorithms, respectively. The simulation results obtained for the reduced order system modeling using PSO and BFO are provided in table 3.

Table 3: Simulation Results for Reduced Order Model using PSO & BFO

Algorithm	ISE	Time taken in sec.
PSO	1.35027	11
BFO	0.99342	7

It is observed that the time taken for optimization process is comparatively higher in PSO search algorithm than BFO search algorithm. The Integral Square Error also comes out minimal in BFO compared to PSO algorithm.

The optimized reduced second order model corresponding to higher order system $G(s)$ can be written as

$$R(s) \Big|_{PSO} = \frac{18s + 5.1379}{s^2 + 6.8976s + 5.1379} \quad (11)$$

$$R(s) \Big|_{BFO} = \frac{18s + 4.9954}{s^2 + 6.567s + 5.0135} \quad (12)$$

We note from table 3 that the proposed scheme yields better value for objective function ISE as compared to other methods.

For a comparison of PSO and BFO, we have studied the step and impulse responses of the original higher order system as well as the reduced order system. The unit step response of the high order system and the optimized step response obtained from PSO and BFO algorithms are shown in Fig. 3. The same for the impulse input are shown in Fig. 4. The figures depict that output produced using both algorithms appears closer to the ideal i.e., the lower order model maintains the original characteristics of the given higher order system.

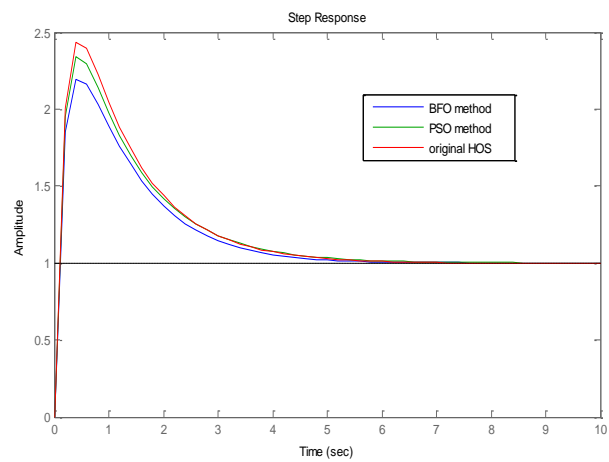

Figure 3: Step response of high order system and ROM using PSO and BFO method

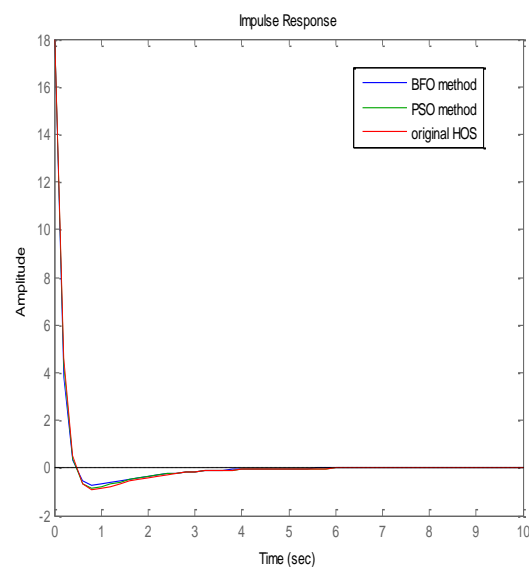

Figure 4: Impulse response of high order system and ROM using PSO and BFO method

5. Conclusion

In this paper, an optimization algorithm for order reduction of linear time invariant dynamic systems has been presented. The reduction algorithm is based on minimization of the integral square error by PSO and BFO techniques pertaining to a unit step and impulse inputs. Also a comparative study has been made using both of the methods. The simulation results indicate that both PSO and BFO can be used in the search of parameters during system modeling. While minimizing the objective function Integral Square Error, the BFO determines a minimal value than does the PSO. In terms of computational time, the BFO approach is faster than PSO. The algorithms PSO and BFO have proved themselves to be effective solutions to the optimization problems. Finally, for both approaches the major issue in implementation is based on the selection of an appropriate objective function.

Acknowledgement

Sudhir Y Kumar would like to thanks Prof. P. K. Das, Dean FET, Mody Institute of Technology and Science (Deemed University), Lakshmanagarh, Dist. Sikar (Rajasthan), India for giving permission to attend the short term course on Bio-inspired Soft computing techniques at NITTTR, Chandigarh, India.

Appendix

Let us consider an n^{th} order LTI continuous high order system represented by its transfer function as:

$$G(s) = \frac{N(s)}{D(s)} = \frac{\sum_{i=0}^{n-1} A_i s^i}{\sum_{i=0}^n a_i s^i} \quad (\text{A.1})$$

$$= \frac{A_{n-1}s^{n-1} + A_{n-2}s^{n-2} + \dots + A_3s^3 + A_2s^2 + A_1s + A_0}{a_n s^n + a_{n-1}s^{n-1} + \dots + a_3s^3 + a_2s^2 + a_1s + a_0}$$

(A.2)

The auxiliary scheme for obtaining the reduced order models from the given higher order system is as follows:

$$\text{First order: } \frac{A_0}{a_1s + a_0} \quad (\text{A.3})$$

$$\text{Second order: } \frac{A_1s + A_0}{a_2s^2 + a_1s + a_0} \quad (\text{A.4})$$

(n-1)th order:

$$\frac{A_{n-2}s^{n-2} + A_{n-3}s^{n-3} + \dots + A_1s + A_0}{a_{n-1}s^{n-1} + a_{n-2}s^{n-2} + \dots + a_1s + a_0} \quad (\text{A.5})$$

Equations (A.3) through (A.5) gives the reduced order models using auxiliary scheme from the given higher order system $G(s)$. Based on the requirement, suitable reduced order model can be selected and coefficients of numerator and denominator of reduced order system can be considered for seed value to invoke the PSO and BFO optimization process.

References

[1] R. Genesio and M. Milanese, "A note on the derivation and use of reduced order models", *IEEE Trans. Automat. Control*, Vol. AC-21, No. 1, pp. 118-122, February 1976.
[2] M. S. Mahmoud and M. G. Singh, *Large Scale Systems Modelling*, Pergamon Press,

International Series on Systems and Control 1st ed., Vol. 3, 1981.
[3] M. Jamshidi, *Large Scale Systems Modelling and Control Series*, New York, Amsterdam, Oxford, North Holland, Vol. 9, 1983.
[4] S. K. Nagar and S. K. Singh, "An algorithmic approach for system decomposition and balanced realized model reduction", *Journal of Franklin Inst.*, Vol. 341, pp. 615-630, 2004.
[5] V. Singh, D. Chandra and H. Kar, "Improved Routh Pade approximants: A computer aided approach", *IEEE Trans. Automat. Control*, Vol. 49, No.2, pp 292-296, February 2004.
[6] S. Mukherjee, Satakshi and R.C.Mittal, "Model order reduction using response-matching technique", *Journal of Franklin Inst.*, Vol. 342, pp. 503-519, 2005.
[7] B. Salimbahrami, and B. Lohmann, "Order reduction of large scale second-order systems using Krylov subspace methods", *Linear Algebra Appl.*, Vol. 415, pp. 385-405, 2006.
[8] S. Mukherjee and R.N. Mishra, "Reduced order modelling of linear multivariable systems using an error minimization technique", *Journal of Franklin Inst.*, Vol. 325, No. 2, pp. 235-245, 1988.
[9] S. S. Lamba, R. Gorez and B. Bandyopadhyay, "New reduction technique by step error minimization for multivariable systems", *Int. J. Systems Sci.*, Vol. 19, No. 6, pp. 999-1009, 1988.
[10] R. Prasad and J. Pal, "Use of continued fraction expansion for stable reduction of linear multivariable systems", *Journal of Institution of Engineers, India, IE(I) Journal – EL*, Vol. 72, pp. 43-47, June 1991.
[11] R. Prasad, A. K. Mittal and S. P. Sharma, "A mixed method for the reduction of multi-variable systems", *Journal of Institution of Engineers, India, IE(I) Journal – EL*, Vol. 85, pp. 177-181, March 2005.
[12] T.C. Chen, C.Y. Chang and K.W. Han, "Reduction of transfer functions by the stability equation method", *Journal of Franklin Inst.*, Vol. 308, No. 4, pp. 389-404, 1979.
[13] T.C. Chen, C.Y. Chang and K.W. Han, "Model reduction using the stability equation method and the continued fraction method", *Int. J. Control*, Vol. 32, No. 1, pp. 81-94, 1980.
[14] C.P. Therapos, "Stability equation method to reduce the order of fast oscillating systems", *Electronic Letters*, Vol. 19, No.5, pp.183-184, March 1983.
[15] T.C. Chen, C.Y. Chang and K.W. Han, "Stable reduced order Pade approximants using stability equation method", *Electronic Letters*, Vol. 16, No. 9, pp. 345-346, 1980.
[16] J. Pal, "Improved Pade approximants using stability equation method", *Electronic Letters*, Vol. 19, No.11, pp.426-427, May 1983.
[17] R. Parthasarathy and K.N. Jayasimha, "System reduction using stability equation method and modified Cauey continued fraction", *Proceedings IEEE*, Vol. 70, No. 10, pp.1234-1236, October 1982.
[18] C. Hwang, "Mixed method of Routh and ISE criterion approaches for reduced order modelling of continuous time systems", *Trans*

ASME, J. Dyn. Syst. Meas. Control, Vol. 106, pp. 353-356, 1984.

- [19] S. Mukherjee, and R.N. Mishra, "Order reduction of linear systems using an error minimization technique", *Journal of Franklin Inst.*, Vol. 323, No. 1, pp. 23-32, 1987.
- [20] N.N. Puri, and D.P. Lan, "Stable model reduction by impulse response error minimization using Mihailov criterion and Pade's approximation", *Trans. ASME, J. Dyn. Syst. Meas. Control*, Vol. 110, pp. 389-394, 1988.
- [21] P. Vilbe, and L.C. Calvez, "On order reduction of linear systems using an error minimization technique", *Journal of Franklin Inst.*, Vol. 327, pp. 513-514, 1990.
- [22] A.K. Mittal, R. Prasad, and S.P. Sharma, "Reduction of linear dynamic systems using an error minimization technique", *Journal of Institution of Engineers IE(I) Journal - EL*, Vol. 84, pp. 201-206, March 2004.
- [23] G.D. Howitt, and R. Luus, "Model reduction by minimization of integral square error performance indices", *Journal of Franklin Inst.*, Vol. 327, pp. 343-357, 1990.
- [24] J. Kennedy and R. Eberhart, "Particle Swarm Optimization", in proceedings, *IEEE International Conference on Neural Networks (ICNN)*, vol.4, Nov 1995, pp.1942-1948.
- [25] K. M. Passino, "Biomimicry of Bacterial Foraging for Distributed Optimization and Control", *IEEE Control System Magazine*, June-2002, pp 52-67.
- [26] S. Mishra, "A hybrid least square-fuzzy bacteria foraging strategy for harmonic estimation", *IEEE Trans. Evolutionary Computation*, Vol. 9, No. 1, Feb.2005, pp. 61-73.



Dr. Shaktidev Mukherjee was born in Patna, India, in 1948. He received B.Sc. (Engg.), Electrical from Patna University in 1968 and M.E., Ph.D. from the University of Roorkee in 1977 and 1989, respectively. After working in industries till 1973, he joined teaching and taught in different academic institutions. He is the former Vice-Chancellor of Mody Institute of Technology and Science, (Deemed University), Lakshmanagarh, Sikar (Rajasthan), India. Presently, he is Professor in the Department of Electrical Engineering at Indian Institute of Technology, Roorkee, India. He is a life member of Systems Society of India (LMSSI). His research interests are in the areas of Model Order Reduction and Process Instrumentation and Control.

Authors Biographies



Sudhir Y Kumar was born in Patna, India in 1974. He received his B. Tech in Electrical and Electronics Engineering from Bangalore university in 1996 and M. Tech in Electrical Power Systems Engineering from National Institute of Technology, Jamshedpur, Jharkhand, India in 2000. Presently, he is working as Assistant Professor in Faculty of Engineering and Technology, Mody, Institute of Technology and Science (Deemed University) at Laxmangarh, Sikar (Rajasthan),

India. He is Associate member of Institution of Engineers, India (AMIE) and Life member of ISTE. His area of interests includes Power systems, Network analysis, Control Systems, and Model Order Reduction of large scale systems.

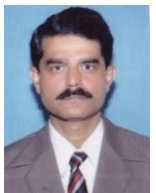

Dr. P. K. Ghosh was born in Kolkata, India in 1964. He received his B.Sc (Hons in Physics), B.Tech and M.Tech degrees in 1986, 1989, and 1991, respectively from Calcutta University. He earned Ph.D.(Tech) degree in Radio Physics and Electronics in 1997 from the same University. He served various institutions, namely, National Institute of Science and Technology (Orissa), St. Xavier's College (Kolkata), Murshidabad College of

Engineering and Technology (West Bengal), R. D. Engineering College (Uttar Pradesh) and Kalyani Government Engineering College (West Bengal) before he joins Mody Institute of Technology and Science (Rajasthan). He is life member of Indian Society for Technical Education (ISTE), New Delhi. His research interests are in the areas of reduced order modeling, VLSI circuits and devices and wireless communications.

The Evaluation of Efficient IP Trace Back with Specified Probability by Inattentive Network Model

Babu.S¹, Kranthi Kumar.G², V N V Phani Kumar .V³

Department of Computer Science and Engineering

V R Siddhartha Engineering College Vijayawada, A.P-520007,India

babunaidu.504@gmail.com¹ gkk15@rediffmail.com² phanikumar.venna@gmail.com³

Abstract: The probabilistic packet marking (PPM) algorithm is a promising way to discover the Internet map or an attack graph that the attack packets traversed during a distributed denial-of-service attack. However, the PPM algorithm is not perfect, as its termination condition is not well defined in the literature. More importantly, without a proper termination condition, the attack graph constructed by the PPM algorithm would be wrong. In this work, we provide a precise termination condition for the PPM algorithm and name the new algorithm the rectified PPM (RPPM) algorithm. The most significant merit of the RPPM algorithm is that when the algorithm terminates, the algorithm guarantees that the constructed attack graph is correct, with a specified level of confidence. We carry out simulations on the RPPM algorithm and show that the RPPM algorithm can guarantee the correctness of the constructed attack graph under 1) different probabilities that a router marks the attack packets and 2) different structures of the network graph. The RPPM algorithm provides an autonomous way for the original PPM algorithm to determine its termination, and it is a promising means of enhancing the reliability of the PPM algorithm.

Key Words: Probabilistic packet marking algorithm and, rectified PPM algorithm, denial of service, internet control message protocol, routing function.

1. Introduction

The denial-of-service (DoS) attack has been a pressing Problem in recent years DoS defense research has blossomed into one of the main streams in network security. Various techniques such as the pushback message, ICMP trace back, and the packet filtering techniques are the results from this active field of research. The probabilistic packet marking (PPM) algorithm has attracted the most attention in contributing the idea of IP trace back. The most interesting point of this IP trace back approach is that it allows routers to encode certain information on the attack packets based on a predetermined probability. Upon receiving a sufficient number of marked packets, the victim (or a data collection node) can construct the set of paths that the attack packets traversed and, hence, the victim can obtain the location(s) of the attacker(s).

1.1 The Probabilistic Packet Marking Algorithm

The goal of the PPM algorithm is to obtain a constructed graph such that the constructed graph is the same as the attack graph, where an attack graph is the set of paths the attack packets traversed, and a constructed graph is a graph returned by the PPM algorithm. To fulfill this goal, Savage et al. [8] suggested a method for encoding the information of the edges of the attack graph into the attack packets through the cooperation of the routers in the attack graph and the victim site. Specifically, the PPM algorithm is made up of two separated procedures: the packet marking procedure, which is executed on the router side, and the graph reconstruction procedure, which is executed on the victim side.

1.1.1 Brief Review of the Packet Marking Procedure

The packet marking procedure aims at encoding every edge of the attack graph, and the routers encode the information in three marking fields of an attack packet: the start, the end, and the distance fields (wherein Savage et al. [8] has discussed the design of the marking fields). In the following, we describe how a packet stores the information about an edge in the attack graph, and the pseudo code of the procedure in [8] is given in Fig. 1 for reference. When a packet arrives at a router, the router determines how the packet can be processed based on a random number x (line number 1 in the pseudo code). If x is smaller than the predefined marking probability pm , the router chooses to start encoding an edge. The router sets the start Field of the incoming packet to the router's address and resets the distance field of that packet to zero. Then, the router forwards the packet to the next router. When the packet arrives at the next router, the router again chooses if it should Start encoding another edge. For example, for this time, the router chooses not to start encoding a new edge. Then, the router will discover that the previous router has started marking an edge, because the distance field of the packet is zero. Eventually, the router sets the end field of the packet to the router's address. Nevertheless, the router increments the Distance field of the packet by one so as to indicate the end of The encoding. Now, the start and the end fields together Encode an edge of the attack graph. For this encoded edge to Be received by the victim, successive routers should choose

not to start encoding an edge, that is, the case $x > p_m$ in the Pseudo code, because a packet can encode only one edge. Furthermore, every successive router will increment the distance field by one so that the victim will know the distance of the encoded edge.

Packet Marking Procedure(Packet w)

1. Let x be a random number in $[0 \dots 1)$
2. **If** $x < p_m$, **then**
3. write router's address into $w.start$ and 0 into $w.distance$
4. **else**
5. **If** $w.distance = 0$ **then**
6. write router's address into $w.end$
7. **end If**
8. increment $w.distance$ by one
9. **end If**

Figure 1: the pseudo code of the packet marking procedure of the PPM algorithm.

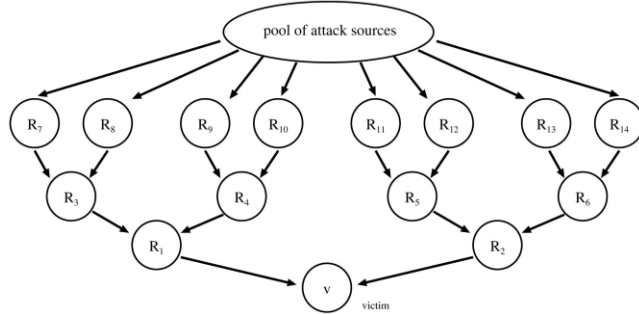

Figure 2: A 14-router binary-tree network.

The upper-bound equation cannot be applied under this multiple-attacker environment

1.1.2 Termination of the PPM Algorithm

According to the above description of the packet marking procedure, although a packet has already encoded an edge, successive routers may choose to start encoding another edge randomly. As a result, when a packet arrives at the victim, the packet may encode any of the edges of the attack graph, or a packet may not encode any edges. Therefore, if the victim can collect a sufficiently large number of marked packets, the victim can successfully construct all the paths in the attack graph by using the graph reconstruction procedure. When the graph reconstruction procedure returns a constructed graph, it implies the termination of the PPM algorithm. However, the termination condition has not thoroughly been investigated in the literature. It turns out that the termination condition is important, because it determines the correctness of the constructed graph: If it stops too early, the constructed graph will not contain enough edges of the attack graph and, thus, fails to fulfill the trace back purpose. In addition, it is also not a proper way to allow the

victim to collect marked packets for a long period before the victim starts the graph reconstruction procedure, because the victim would never know how much time is long enough. Hence, a proper termination condition can also help in speeding up the trace back process. In [8], Savage et al. have provided an estimation of the number of marked packets required before the victim can have a constructed graph that is the same as the attack graph under a single-attacker environment. Let X be the number of marked packets required for the victim to reconstruct a path.

2. Rectified Probabilistic Packet Marking Algorithm

The RPPM algorithm is designed to automatically determine when the algorithm should terminate. We aim at achieving the following properties:

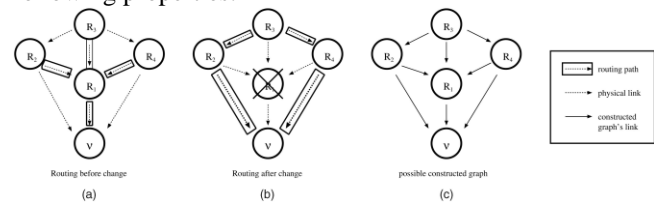

Figure 6: The failure of the router R1 causes the route tables of R2, R3, and R4 to change. This results in a constructed graph with routers that have multiple outgoing edges

1. The algorithm does not require any prior knowledge about the network topology.
2. The algorithm determines the certainty that the constructed graph is the attack graph when the algorithm terminates.

Our goal is to devise an algorithm that guarantees that the constructed graph is the same as the attack graph with probability greater than P_* , where we name P_* the trace back confidence level (it is analogous to the level of confidence that the algorithm wants to achieve). To accomplish this goal, the graph reconstruction procedure of the original PPM algorithm is completely replaced, and we name the new procedure the rectified graph reconstruction procedure. On the other hand, we preserve the packet marking procedure so that every router deployed with the PPM algorithm is not required to change. In the following section, we list the assumptions of our solution. Then, we describe the flow of the rectified graph reconstruction procedure. For example, in Fig. 6, the failure of the router R1 forces the routing table to completely change. Under such a scenario, the constructed attack graph may become the one shown in Fig. 6c. We argue that this result is not an undesirable one, as long as the definition of a correct attack graph construction still holds (because the new attack graph is indeed composed of all the edges traversed by the packets). In the remainder of this paper, we stay with this assumption, and we will discuss the scenario when this assumption is relaxed in Section 6.

2.1.2 Assumptions about the Victim

On the victim side, we assume that by the time that the victim starts collecting marked packets, all routers in the network have already invoked the packet marking procedure. In addition, we assume that the victim does not have any knowledge about the real network or the attack graph. However, the victim knows the marking probability that the routers are using.

2.2 Flow of the Rectified Graph Reconstruction Procedure

The pseudo code of the rectified graph reconstruction procedure is shown in Fig. 7, and the procedure is started as soon as the victim starts collecting marked packets. When a marked packet arrives at the victim, the procedure first checks if this packet encodes a new edge.

Rectified Graph Reconstruction Procedure (Traceback Confidence Level P^*)

```

/* Initially,  $G_e$  contains the "victim" node only, and  $pkt\_count = 0$ . */
1. Foreach incoming packet  $pkt$  ; do
2.    $pkt\_count := pkt\_count + 1$ ;
3.   If the incoming packet  $pkt$  contains an edge  $e$  that is not included in  $G_e$ ; then
4.     Construct the new attack graph  $G_e$  by inserting the edge  $e$  ;
5.     If  $G_e$  is a connected graph ; then
6.        $TPN := TPN\_subroutine(G_e, P^*)$  ;
7.        $pkt\_count := 0$  ;
8.     end If
9.   end If
10.  If  $G_e$  is a connected graph ; then
11.    If  $pkt\_count > TPN$  ; then
12.      Return  $G_e$  as the constructed graph ;
13.    end If
14.  end If
15. end Foreach
    
```

Figure 7: The pseudo code of the rectified graph reconstruction

Procedure of the RPPM algorithm

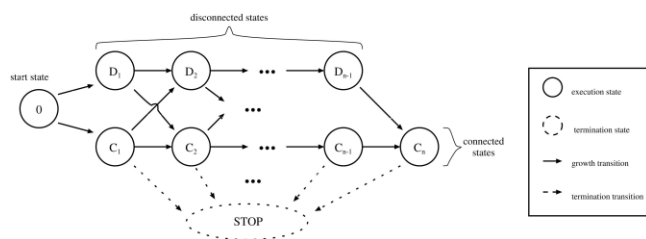

Figure 8: An execution diagram of the rectified graph reconstruction procedure of the RPPM algorithm that constructs a graph with n edges procedure accordingly updates the constructed graph G_c . Next, if the constructed graph is connected, where connected means that every router can reach the victim, the procedure calculates the number of incoming packets required before the algorithm

stops, and we name this number the TPN. The procedure then resets the counter for the incoming packets to zero and starts counting the number of incoming packets. In the meantime, the procedure checks if the number of collected packets is larger than the TPN. If so, the procedure claims that the constructed graph G_c is the attack graph, with probability P_* . Otherwise, the victim receives a packet that encodes a new edge. Then, the procedure updates the constructed graph, revisits the TPN calculation subroutine, resets the counter for incoming packets, and waits until a packet that encodes a new edge arrives or the number of incoming packets is larger than the new TPN. As suggested by the pseudo code, the termination condition of the RPPM algorithm is that “the counter for the incoming packets is larger than the TPN,” and this implies that the calculation of the TPN during each update of the constructed graph is the core of the RPPM algorithm. In the next step, we provide a deeper understanding of the RPPM algorithm through the introduction of the execution diagram.

2.3 Execution Diagram of the rectified Probabilistic Packet Marking Algorithm.

According to the previous section, it is observed that the TPN, the constructed graph, and the execution of the rectified graph reconstruction procedure are closely related. Such a relationship can be visualized by the construction of the execution diagram, as shown in Fig. 8. The execution diagram presents the dynamics of the execution of the rectified graph reconstruction procedure.

2.3.1 Types of States

There are two types of states in the diagram: the execution state and the termination state. When the procedure is running, we say that “the rectified graph reconstruction procedure is in an execution state.” Otherwise, we say that “the rectified graph reconstruction procedure is in the termination state.” The execution state also tells us the state of the constructed graph:

- 1) When the procedure is in the start state, labeled by “0,” it means that the procedure has started running, and there are no edges in the constructed graph.
- 2) When the procedure is in a connected state, it means that the constructed graph is connected. A connected state, labeled by C_i , means that the Constructed graph is connected and contains i edges.
- 3) When the procedure is in a disconnected state, the constructed graph is disconnected. A disconnected state, labeled by D_i , means that the constructed graph is disconnected and contains i edges. Note that both the connected and disconnected states, say, C_i and D_i , respectively, refer to all the possible graphs that have i edges. Last, when the procedure is in the termination state, it means that the procedure has stopped.

2.3.2 Types of Transitions

There are two kinds of transitions in the execution diagram. When the procedure takes a growth transition, it means that a new edge is added to the constructed graph. When the procedure takes a termination transition, it means that the procedure is going to stop running. The transition structure in Fig. 8 is derived from the pseudo code of the rectified graph reconstruction procedure in Fig. 7. We briefly describe the transition structure as follows: 1) If a packet that encodes a new edge arrives before the number of received packets is larger than the TPN, then the procedure takes a growth transition and proceeds to either a connected state or a disconnected state, depending on the connectivity of the updated constructed graph. 2) If the number of received packets is larger than the TPN, then the procedure takes the termination transition and proceeds to the termination state. 3) If the procedure is in one of the disconnected states, then it is meaningless to return such a graph as the correct constructed graph, and there is no transition that connects the disconnected states to the termination state. The procedure then keeps on collecting packets until it proceeds to a connected state.

2.4 Role of the Execution Diagram

The execution diagram provides a thorough understanding of the relationship among the execution of the rectified graph reconstruction procedure, the constructed graph, and the TPN. Through the analysis of the execution diagram, it can be observed that different execution scenarios of the procedure would affect the probability that the procedure returns a correct constructed graph. It is observed that the worst-case scenario would be the hardest case for the rectified graph reconstruction procedure to return a correct graph. Therefore, it is an ideal point for us to derive the calculation of the TPN. Supposing that one could successfully provide a guarantee of the correctness of the constructed graph under the worst-case scenario, then such a guarantee can also be provided in the average-case scenario. Moreover, it is expected that the average-case scenario should outperform the worst-case scenario in terms of the successful rate of returning a correct constructed graph. Next, we will move on to the modeling of the packet marking process of the packet marking procedure.

3. Packet-Types Probability

The packet marking procedure is the source of different kinds of marked packets, and the total number of possible marked packets is the number of edges of the attack graph. However, it will be shown in the next section that the probability for every kind of marked packet that arrive at the victim plays a vital part in the derivation of the termination packet number. In this section, we present the

definition and the derivation of such a set of probabilities, and we name them the packet-type probabilities.

3.1 Encoded Edge Random Variable

By definition, an incoming packet may encode one of the edges of the attack graph, or the incoming packet does not encode any edges of the attack graph. We use a random variable called the encoded edge random variable to represent all possible encodings on an incoming packet. We formally define the encoded edge random variable as follows:

3.2 Procedure aims at encoding every edge

The routers encode the information in three marking fields of an attack packet: the start, the end, and the distance fields. In the following, we describe how a packet stores the information about an edge in the attack graph, and the pseudo code of the procedure is given in reference. When a packet arrives at a router, the router determines how the packet can be processed based on a random number x (line number 1 in the pseudo code). If x is smaller than the predefined marking probability p_m , the router chooses to start encoding an edge. The router sets the start field of the incoming packet to the router's address and resets the distance field of that packet to zero. Then, the router forwards the packet to the next router. When the packet arrives at the next router, the router again chooses if it should start encoding another edge. For example, for this time, the router chooses not to start encoding a new edge. Then, the router will discover that the previous router has started marking an edge, because the distance field of the packet is zero. Eventually, the router sets the end field of the packet to the router's address. Nevertheless, the router increments the distance field of the packet by one so as to indicate the end of the encoding. Now, the start and the end fields together encode an edge of the attack graph. For this encoded edge to be received by the victim, successive routers should choose not to start encoding an edge, that is, the case $x > p_m$ in the pseudo code, because a packet can encode only one edge. Furthermore, every successive router will increment the chooses if it should start encoding another edge. For example, for this time, the router chooses not to start encoding a new edge. Then, the router will discover that the previous router has started marking an edge, because the distance field of the packet is zero. Eventually, the router sets the end field of the packet to the router's address. Nevertheless, the router increments the distance field of the packet by one so as to indicate the end of the encoding. Now, the start and the end fields together encode an edge of the attack graph. For this encoded edge to be received by the victim, successive routers should choose not to start encoding an edge, that is, the case $x > p_m$ in the pseudo code, because a packet can encode only one edge. Furthermore, every successive router will increment the The PPM algorithm is made up of two separated procedures:

- The packet marking procedure:

- Which is executed on the router side?
- The graph reconstruction procedure:
Which is executed on the victim side?

3.3 Rectified problem the user use RPPM algorithm

To propose termination condition of the PPM algorithm, this is missing or is not explicitly defined in the literature. Through the new termination condition, the user of the new algorithm is free to determine the correctness of the constructed graph. The constructed graph is guaranteed to reach the correctness assigned by the user, independent of the marking probability and the structure of the underlying network graph.

4. Goal of the project

1. We introduce the termination condition of the PPM algorithm, which is missing or is not explicitly defined in the literature.
2. Through the new termination condition, the user of the new algorithm is free to determine the correctness of the constructed graph.
3. The user to construct overall structure of the network graph.

5. Deployment Issue of The Rectified Probabilistic Packet Marking Algorithm.

In this section, we discuss several issues in deploying the RPPM algorithm. We first discuss the choice in the marking Probability. Then, we cover the trade-off of the RPPM Algorithm over the PPM algorithm. Last, we address the Scalability problem in the PPM and the RPPM algorithms.

5.1 Choice of the Marking Probability

It is not desirable to have a high value of the marking probability. First, a high value of the marking probability means a low value for the packet-type probabilities for the majority of the types of packets. Hence, this implies that a large number of marked packets are needed before the RPPM algorithm stops. This also implies a long execution time of the RPPM algorithm. Let us take a linear network with three routers and one victim (as shown in Fig. 12) as an example to illustrate the relationship between the marking probability and the number of packets required. Fig. 23 shows the result of a simulation that aims at counting the average number of marked packets required for a correct graph reconstruction with different values of the marking probability. The result shows that for small values of marking probability, the number of required packets is small. Nevertheless, the number of required

packets dramatically increases for large values of the marking probability. Despite the above reason, according to Section 5, a high value of the marking probability implies the presence of the worst-case scenario of the RPPM algorithm. Although the worst-case scenario can still guarantee the successful rate, it would be more beneficial to set the value of the marking probability to a lower value so as to gain a larger successful rate than what is expected. In conclusion, one should choose a small value for the marking probability for a faster and more reliable graph reconstruction. Note that there would be a large number of unmarked packets if one chooses a too-small value of the marking probability.

6. Execution Time Comparison between the PPM and the RPPM Algorithms.

In order to guarantee the correctness of the constructed graph, the RPPM algorithm has to collect extra packets so as to attain such a guarantee. Technically speaking, before the moment that the constructed graph becomes the same as the attack graph, the number of marked packets collected should be the same for both the PPM and RPPM algorithms. After the constructed graph has become the attack graph, the RPPM algorithm has to wait until the number of collected packets is larger than the TPN. In other words, that extra sum of packets is the trade-off in deploying the RPPM algorithm than the PPM algorithm. However, it is difficult to determine a theoretical value or bound of the TPN, because the TPN calculation depends on the construction process of the constructed graph. The construction process, in turn, depends on the sequence of the arrivals of the marked packets, which is randomized. Alternatively, we conduct an empirical study on the trade-off of the RPPM algorithm. We present the number of increased marked packets when one compares the number of packets collected by the RPPM algorithm to those collected by the PPM algorithm (which is instructed to stop when the constructed graph becomes the attack graph). Such a set of simulations is performed using a marking probability of 0.1 (as suggested with increasing network scales: from a 15-node Random-tree network to a 1,000-node one). The RPPM Algorithm is operated under the average-case scenario. Three main observations can be concluded from this set of Simulations. First, when the trace back confidence level Increases, the trade-off of the RPPM algorithm increases. Second, the number of collected packets by the RPPM algorithm is larger than those collected by the PPM algorithm by several times for the small range of the trace back Confidence level (two to five times for the trace back TABLE 1The Average Number of Packets and the Time Required to Reconstruct a Correct Constructed Graph in a 100BaseT Ethernet

Number of Nodes	15	50	100	500	1000
Average number of marked packets required for PPM algorithm	92	1170	1550	15222	40792
Average time required in 100BaseT Ethernet (in second)	0.011	0.140	0.180	1.820	4.910

Confidence level below 0.8), and such an increase reaches 10 times for high values of the trace back confidence level. Last, an interesting observation is that the trade-offs for small networks are more significant than those for large networks. This can be explained by the probability of forming a disconnected graph. For a large network, such a probability is much higher than that of a small network.

When a disconnected graph is formed, the TPN calculation is skipped until the graph becomes connected. Hence, this keeps the value of the TPN small during the ending states of the RPPM algorithm. On the other hand, according to Table 1, one can observe that the time for the PPM algorithm to collect enough packets is in the order of a few seconds in a 100BaseT Ethernet. Therefore, although the trade-off of the RPPM algorithm could reach a multiple of 10, such a trade-off is acceptable.

7. Scalability

Scalability is one of the weaknesses of the PPM algorithm. One can observe that as the path length between the victim and the leaf router becomes longer, it becomes more difficult to collect a complete set of the marked packets. The case is that not only the path length affects the trace back time but the size of the attack graph also matters. One can observe that the number of marked packets required to build the constructed graph increases with the size of the graph, and the trend does not subside. Therefore, the PPM algorithm itself has a scalability problem. Nonetheless, as the RPPM algorithm inherits the packet marking procedure from the PPM algorithm, the RPPM algorithm also has the scalability problem. As suggested in Section , for small networks, the trace back process takes only a few seconds to complete. However, for networks as large as the one in [19] (with nearly 200,000 routers and more than 600,000 directed links), the trace back process may take days to finish.

8. Conclusion and Future Work

In this work, we have pinpointed that the PPM algorithm lacks a proper definition of the termination condition. Meanwhile, using the expected number of required marked packets $E\frac{1}{2}X$ as the termination condition is not sufficient. The above two outstanding problems only lead to an undesirable outcome: there is no guarantee of the correctness of the constructed graph produced by the PPM algorithm. We have devised the rectified graph reconstruction procedure to solve the above two problems, and we name the new trace back approach the RPPM algorithm.

The RPPM algorithm, on one hand, does not require any previous knowledge about the network graph. On the other hand, it guarantees that the constructed graph is a correct one, with a specified probability, and such a probability is an input parameter of the algorithm. We have

carried out a series of simulations to show the correctness and the robustness of the RPPM algorithm. The simulation results show that the RPPM algorithm can always satisfy our claim that the constructed graph is correct with a given probability. In addition, the algorithm is robust under different values of the marking probability and different structures of the attack graphs. To conclude, the RPPM algorithm is an effective means of improving the reliability of the original PPM algorithm. Since the RPPM algorithm is an extension of the PPM algorithm, the RPPM algorithm inherits defects of the PPM algorithm. Problems such as scalability and different attack patterns will be future research directions.

9. ACKNOWLEDGMENTS

This research was supported by grant from Department of Computer Science and Engineering in V R Siddhartha Engineering College, Vijayawada.

10. Reference:

- [1] "CERT Advisory CA-2000-01: Denial-of-Service Developments," Computer Emergency Response Team, <http://www.cert.org/-advisories/-CA-2000-01.html>, 2006.
- [2] J. Ioannidis and S.M. Bellovin, "Implementing Pushback: Router- Based Defense against DDoS Attacks," Proc. Network and Distributed System Security Symp., pp. 100-108, Feb. 2002.
- [3] S. Bellovin, M. Leech, and T. Taylor, ICMP Trace back Messages, Internet Draft Draft-Bellovin-Itrace-04.txt, Feb. 2003.
- [4] K. Park and H. Lee, "On the Effectiveness of Route-Based Packet Filtering for Distributed DoS Attack Prevention in Power-Law Internets," Proc. ACM SIGCOMM '01, pp. 15-26, 2001.
- [5] P. Ferguson and D. Senie, "RFC 2267: Network Ingress Filtering: Defeating Denial of Service Attacks Which Employ IP Source Address Spoofing," The Internet Soc., Jan. 1998.
- [6] D.K.Y. Yau, J.C.S. Lui, F. Liang, and Y. Yam, "Defending against Distributed Denial-of-Service Attacks with Max-Min Fair Server- Centric Router Throttles," IEEE/ACM Trans. Networking, no. 1, pp. 29-42, 2005.
- [7] C.W. Tan, D.M. Chiu, J.C. Lui, and D.K.Y. Yau, "A Distributed Throttling Approach for Handling High-Bandwidth Aggregates," IEEE Trans. Parallel and Distributed Systems, vol. 18, no. 7, pp. 983-995, July 2007.
- [8] S. Savage, D. Wetherall, A. Karlin, and T. Anderson, "Practical Network Support for IP Traceback," Proc. ACM SIGCOMM '00, pp. 295-306, 2000.
- [9] D. Dean, M. Franklin, and A. Stubblefield, "An Algebraic Approach to IP Traceback," ACM Trans. Information and System Security, vol. 5, no. 2, pp. 119-137, 2002.
- [10] D.X. Song and A. Perrig, "Advanced and Authenticated Marking Schemes for IP Traceback," Proc. IEEE INFOCOM '01, pp. 878-886, Apr. 2001.

- [11] A.C. Snoeren, C. Partridge, L.A. Sanchez, C.E. Jones, F. Tchakountio, S.T. Kent, and W.T. Strayer, "Hash-Based IP Traceback," Proc. ACM SIGCOMM '01, pp. 3-14, Aug. 2001.
- [12] K. Park and H. Lee, "On the Effectiveness of Probabilistic Packet Marking for IP Traceback under Denial-of-Service Attacks," Proc. IEEE INFOCOM '01, pp. 338-347, 2001.
- [13] K.T. Law, J.C.S. Lui, and D.K.Y. Yau, "You Can Run, But You Can't Hide: An Effective Methodology to Traceback DDoS Attackers," IEEE Trans. Parallel and Distributed Systems, vol. 15, no. 9, pp. 799-813, Sept. 2005.
- [14] M. Adler, "Trade-Offs in Probabilistic Packet Marking for IP Traceback," J. ACM, vol. 52, pp. 217-244, Mar. 2005.
- [15] H. von Schelling, "Coupon Collecting for Unequal Probabilities," Am. Math. Monthly, vol. 61, pp. 306-311, 1954.

LMI Condition for Synchronization of Neural Network with Parameter

Lu Dianchen* and Qi Qiaoxia

Nonlinear Scientific Research Center,

Jiangsu University, Zhenjiang Jiangsu, 212013, P.R. China

haijianshao@yamil.com

Abstract - In this paper, an successful LMI approach to global synchronization of multi-delay Hopfield neural network with parameter perturbations model to be analyzed by constructing an appropriate Lyapunov-Krasovskii functional, given in a matrix condition based on global stability, and the numerical simulation is used to verify the main results of this paper.

Key Words: Parameter perturbations, Global synchronization; LMI condition

1. Introduction

Hopfield neural network is a typical recurrent neural network, which has strong associative memory and optimization of computing power, so the dynamic properties of the model has received extensive attention [1-6], and achieved rich results. Hopfield neural networks (HNNs) are first proposed in with an electrical circuit implementation [7, 8], many essential features of these networks, such as qualitative properties of stability, oscillation, and convergence issues have been investigated by many authors [9, 10]. HNNs have been extensively investigated over the years, and various sufficient conditions for the stability of the equilibrium point of this class of neural networks have been presented in[8, 11-13]. However, in some applications, system delays are frequently fixed and their bounds are known. In addition, several famous neural networks are special cases of DHNNs, such as cellular neural networks (CNN) [14-17].

In this paper, we consider a class of multi-delay Hopfield neural network with parameter perturbations described by a nonlinear delay differential equation of neutral-type. By constructing a suitable Lyapunov functional, a novel condition for the stability of HNNs of neutral-type is given in terms of linear matrix inequality.

2. Problem formulation

Considering the following multi-delay Hopfield neural network with parameter perturbations model

$$\dot{x}(t) = -(C + \Delta C)x(t) + (T_0 + \Delta T_0)S(x(t)) + \sum_{k=1}^K (T_k + \Delta T_k)S(x(t - \tau_k)) + I \quad (1)$$

where $\Delta C = \text{diag}[\Delta c_1, \Delta c_2, \dots, \Delta c_n] \in R^{n \times n}$,

$\Delta T_k \in R^{n \times n}$ are norm-bounded time-varying matrix

of uncertain items, $x = (x_1, x_2, \dots, x_n)^T \in R^n$ is the state variable that neurons associated with ;

$C = \text{diag}[c_1, c_2, \dots, c_n]$, $c_i > 0 (1 \leq i \leq n)$ is a diagonal matrix which indicates the feedback of that neurons; $T_0 \in R^{n \times n}$ is not associated with the delay

of the interconnect $\tau_k (k = 1, 2, \dots, K)$, $T_k \in R^{n \times n}$ is associated with the delay of the interconnect τ_k

($k = 1, 2, \dots, K$), τ_k is the Kth delay, and

$0 < \tau_1 < \dots < \tau_k < +\infty$; $I = (I_1, I_2, \dots, I_n) \in R^n$ is a constant input vector;

$S(x) = [s_1(x_1), s_2(x_2), \dots, s_n(x_n)]^T$, $s_i(x_i)$ is activation and bounded function, and $s_i(0) = 0$;

The initial function of system is $x(s) = \varphi(s)$, where, $s \in [-\tau_k, 0]$, $\varphi \in C([-\tau_k, 0], R^n)$.

Assumption 1. The neuron activation functions $S_i(\cdot)$ is Lipschitz continuous and monotonically

nondecreasing. Specifically, there exist constant

$l_i > 0$ such that:

$$0 \leq \frac{S_i(a) - S_i(b)}{a - b} \leq l_i, \quad (2)$$

For any $a, b \in R, a \neq b, i = 1, 2, \dots, n$.

Assumption 2. System (1) item parameter perturbation ΔC and ΔT_k norm-bounded, and

satisfy the following matching conditions:

$$[\Delta C, \Delta T_0, \dots, \Delta T_K] = HF[A, B_0, \dots, B_K], \quad (k = 0, 1, \dots, K) \quad (3)$$

where F is Parameter uncertainty, represented by the unknown matrix, and satisfy

$F^T F \leq I, A, B_0, \dots, B_K$ are the uncertainty that

has the appropriate dimension of the constant matrix.

Assume that $x^* = (x_1^*, x_2^*, \dots, x_n^*)^T$ is an

equilibrium point of the Eq. (1), then we will shift

the equilibrium point x^* to the origin. The

transformation $\tilde{x}_i(\cdot) = x_i(\cdot) - x_i^*$ puts system (1)

into the following form:

$$\dot{\tilde{x}}(t) = -(C + \Delta C)\tilde{x}(t) + (T_0 + \Delta T_0)\tilde{S}(\tilde{x}(t)) + \sum_{k=1}^K (T_k + \Delta T_k)\tilde{S}(\tilde{x}(t - \tau_k)) \quad (4)$$

It might be $\dot{\tilde{x}}(t)$ shorthand for $\dot{y}(t)$, then we

have as follows

$$\dot{y}(t) = -(C + \Delta C)y(t) + (T_0 + \Delta T_0)\tilde{S}(y(t)) + \sum_{k=1}^K (T_k + \Delta T_k)\tilde{S}(y(t - \tau_k)) \quad (5)$$

where $y(t)$ is the state vector of the transformed system,

$$\tilde{S}(y(t)) = [\tilde{S}_1(y_1(t)), \tilde{S}_2(y_2(t)), \dots, \tilde{S}_n(y_n(t))]^T,$$

$$\tilde{S}_i(y_i(t)) = S_i(y_i(t) + x_i^*) - S_i(x_i^*)$$

with $\tilde{S}_i(0) = 0, (i = 1, 2, \dots, n)$, S_i

$(i = 1, 2, \dots, n)$ satisfy assumption (A1).

The following facts and lemma will be used for deriving main result.

Fact1. (Schur complement) Given constant symmetric matrices $\Sigma_1, \Sigma_2, \Sigma_3$ where

$$\Sigma_1 = \Sigma_1^T \quad \text{and} \quad 0 < \Sigma_2 = \Sigma_2^T, \quad \text{then}$$

$$\Sigma_1 + \Sigma_3 \Sigma_2^{-1} \Sigma_3 < 0 \text{ if and only if: } \begin{pmatrix} \Sigma_1 & \Sigma_3 \\ \Sigma_3 & -\Sigma_2 \end{pmatrix} < 0$$

Fact 2. For any real vector a, b and any matrix

$Q > 0$, with appropriate dimensions, it follows that:

$$a^T b \leq \frac{1}{2} a^T Q a + \frac{1}{2} b^T Q^{-1} b$$

Lemma 1.[18] The follows matrices U, V, W

and M satisfy $M = M^T$, Then for all the matrix

$V^T V \leq I$, Has the following formula for the

establishment of $M + UVW + W^T V^T U^T < 0$, If and

only if there is a constant $\varepsilon > 0$, brought as follows

$$M + \varepsilon^{-1} U U^T + \varepsilon W^T W < 0.$$

Lemma 2.[19] For a positive matrix $Q > 0$,

any matrices $G, F_1, F_2, F_3, F_4, F_5, F_6$, and scalar

$$\tau_k \geq 0 (k = 1, 2, \dots, K), \quad \text{the following}$$

inequality holds:

$$-\sum_{k=1}^K \int_{t-\tau_k}^t \dot{y}^T(s) Q \dot{y}(s) ds \leq \sum_{k=1}^K \zeta_k^T(t) \tilde{F} \zeta_k(t) + \sum_{k=1}^K \tau_k \zeta_k^T(t) F^T Q^{-1} \zeta_k(t),$$

where

$$\tilde{F} = \begin{pmatrix} 0 & 0 & F_1^T & 0 & 0 & 0 \\ * & 0 & F_2^T & 0 & 0 & 0 \\ * & * & F_3^T + F_3 & F_4 & F_5 & F_6 \\ * & * & * & 0 & 0 & 0 \\ * & * & * & * & 0 & 0 \\ * & * & * & * & * & 0 \end{pmatrix},$$

$$F = [F_1, F_2, F_3, F_4, F_5, F_6],$$

$$\zeta_k^T(t) = [y^T(t), y^T(t - \tau_k), (\int_{t-\tau_k}^t \dot{y}(s) ds)^T, \dot{y}^T(t), \dot{y}^T(t - \tau_k), \tilde{S}^T(y(t - \tau_k))].$$

Proof. Utilizing Fact 2, we have:

$$-\sum_{k=1}^K \int_{t-\tau_k}^t \dot{y}^T(s) Q \dot{y}(s) ds \leq 2 \sum_{k=1}^K (\int_{t-\tau_k}^t \dot{y}^T(s) ds)^T (F \zeta_k(t) + \sum_{k=1}^K \int_{t-\tau_k}^t \zeta_k^T(t) F^T Q^{-1} F \zeta_k(t) ds)$$

$$\leq 2 \sum_{k=1}^K \begin{bmatrix} 0 \\ 0 \\ I \\ 0 \\ 0 \\ 0 \end{bmatrix} F \zeta_k(t) + \sum_{k=1}^K \tau_k \zeta_k^T(t) F^T Q^{-1} F \zeta_k(t) \leq \sum_{k=1}^K \zeta_k^T(t) \tilde{F} \zeta_k(t) + \sum_{k=1}^K \tau_k \zeta_k^T(t) F^T Q^{-1} F \zeta_k(t)$$

3. Main results

In this section, we derive a new delay-dependent criterion for asymptotic stability of the system (5) using the Lyapunov method combining with linear matrix inequality framework.

Before presenting our main result, by utilizing the following zero equation:

$$K G y(t) - \sum_{k=1}^K G y(t - \tau_k) - \sum_{k=1}^K G \int_{t-\tau_k}^t \dot{y}(s) ds = 0, \quad (6)$$

for a matrix $G \in R^{n \times n}$ of appropriate dimension, we can represent the system (5) as:

$$\begin{aligned} \dot{y}(t) = & -(C + \Delta C - KG)y(t) - \sum_{k=1}^K G y(t - \tau_k) + (T_0 + \Delta T_0) \tilde{S}(y(t)) \\ & + \sum_{k=1}^K (T_k + \Delta T_k) \tilde{S}(y(t - \tau_k)) - \sum_{k=1}^K G \int_{t-\tau_k}^t \dot{y}(s) ds \end{aligned} \quad (7)$$

Then we have the following theorem.

Theorem 1. For given $\tau_k > 0 (k=1,2,\dots,K)$,

$L = \text{diag}\{l_1, l_2, \dots, l_n\}$, the equilibrium point of Eq.(5)

is globally asymptotically stable if there exist positive definite matrices P, U, Z, Q , and any matrices $M_i, F_i (i=1,2,\dots,6)$, satisfying the following LMI:

$$\begin{bmatrix} \bar{Y}_{k11} & -\frac{2G}{K} + \frac{L}{K} T_k - M_1 + M_2^T & -\frac{2G}{K} + F_1^T - M_1 + M_3^T & M_4^T & M_5^T & M_6^T & F_1^T \\ * & -U - M_2 - M_2^T & -M_2 - M_3^T + F_2^T & -M_4^T & -M_5^T & -M_6^T & F_2^T \\ * & * & -M_3 - M_3^T + F_3 + F_3^T & F_4 & F_5 & F_6 & F_3^T \\ * & * & * & \tau_k Q + R & 0 & 0 & F_4^T \\ * & * & * & * & -R & 0 & F_5^T \\ * & * & * & * & * & -Z & F_6^T \\ * & * & * & * & * & * & -\tau_k Q \end{bmatrix} < 0 \quad (8)$$

$$\bar{Y}_{k11} = -P(C - KG) - (C - KG)^T P + \frac{2L}{K^2} T_0 + U + L^2 Z + M_1 + M_1^T + \frac{2L}{K^2} H F B_0 - \frac{1}{\varepsilon} P H H^T P + \varepsilon A^T A + \frac{L}{K} H F B_k$$

Proof. Considering the following Lyapunov function

$$\begin{aligned} V(t) = & y^T(t) P y(t) + \sum_{k=1}^K \int_{t-\tau_k}^t y^T(s) U y(s) ds + \sum_{k=1}^K \int_{t-\tau_k}^t \int_s y^T(u) Q \dot{y}(u) du ds \\ & + \sum_{k=1}^K \int_{t-\tau_k}^t \dot{y}^T(s) R \dot{y}(s) ds + \sum_{k=1}^K \int_{t-\tau_k}^t \tilde{S}^T(y(s)) Z \tilde{S}(y(s)) ds \end{aligned} \quad (9)$$

where $P^T = P$, then we can get that as follows

$$\begin{aligned} \dot{V}(t) \leq & y^T(t) (-P(C + \Delta C - KG) - (C + \Delta C - KG)^T P) y(t) + 2y^T(t) \left(-\sum_{k=1}^K G y(t - \tau_k) + (T_0 + \Delta T_0) \tilde{S}(y(t)) \right. \\ & + \sum_{k=1}^K (T_k + \Delta T_k) \tilde{S}(y(t - \tau_k)) - \sum_{k=1}^K G \int_{t-\tau_k}^t \dot{y}(s) ds \Big) + \sum_{k=1}^K y^T(t) U y(t) - \sum_{k=1}^K y^T(t - \tau_k) U y(t - \tau_k) \\ & + \sum_{k=1}^K \zeta_k^T(t) \tilde{F} \zeta_k(t) + \sum_{k=1}^K \tau_k \zeta_k^T(t) F^T Q^{-1} F \zeta_k(t) + \sum_{k=1}^K \tau_k \dot{y}^T(t) Q \dot{y}(t) + \sum_{k=1}^K \dot{y}^T(t) R \dot{y}(t) \\ & - \sum_{k=1}^K \dot{y}^T(t - \tau_k) R \dot{y}(t - \tau_k) + \sum_{k=1}^K \tilde{S}^T(y(t)) Z \tilde{S}(y(t)) - \sum_{k=1}^K \tilde{S}^T(y(t - \tau_k)) Z \tilde{S}(y(t - \tau_k)) \\ = & y^T(t) (-P(C + \Delta C - KG) - (C + \Delta C - KG)^T P) y(t) + \sum_{k=1}^K [2K^{-1} y^T(t) (-G y(t - \tau_k) \\ & + K^{-1} (T_0 + \Delta T_0) \tilde{S}(y(t)) + (T_k + \Delta T_k) \tilde{S}(y(t - \tau_k)) - G \int_{t-\tau_k}^t \dot{y}(s) ds) + y^T(t) U y(t) \\ & - y^T(t - \tau_k) U y(t - \tau_k) + \zeta_k^T(t) \tilde{F} \zeta_k(t) + \tilde{S}^T(y(t)) Z \tilde{S}(y(t)) + \tau_k \zeta_k^T(t) F^T Q^{-1} F \zeta_k(t) \\ & + \tau_k \dot{y}^T(t) Q \dot{y}(t) + \dot{y}^T(t) R \dot{y}(t) - \dot{y}^T(t - \tau_k) R \dot{y}(t - \tau_k) - \tilde{S}^T(y(t - \tau_k)) Z \tilde{S}(y(t - \tau_k))] \end{aligned}$$

As a tool of deriving a less conservative stability criterion, we add the following one zero equation with and matrix $M_i (i=1,2,\dots,6)$ to be chosen as:

$$\begin{aligned} 2[y^T(t) M_1 + y^T(t - \tau_k) M_2 + \left(\int_{t-\tau_k}^t \dot{y}(s) ds \right)^T M_3 + y^T(t) M_4 + \dot{y}^T(t - \tau_k) M_5 + \tilde{S}^T(y(t - \tau_k)) M_6] \\ \times [y(t) - y(t - \tau_k) - \int_{t-\tau_k}^t \dot{y}(s) ds] = 0 \end{aligned} \quad (16)$$

The equality (18) can be represented as:

$$\sum_{k=1}^K \zeta_k^T(t) \Xi_1 \zeta_k(t) = 0$$

where

$$\zeta_k^T(t) = [y^T(t), y^T(t - \tau_k), (\int_{t-\tau_k}^t \dot{y}(s) ds)^T, \dot{y}^T(t), \dot{y}^T(t - \tau_k), \tilde{S}^T(y(t - \tau_k))],$$

$$\Xi_1 = \begin{pmatrix} M_1 + M_1^T & -M_1 + M_2^T & -M_1 + M_3^T & M_4^T & M_5^T & M_6^T \\ * & -M_2 - M_2^T & -M_2 - M_3^T & -M_4^T & -M_5^T & -M_6^T \\ * & * & -M_3 - M_3^T & -M_4^T & -M_5^T & -M_6^T \\ * & * & * & 0 & 0 & 0 \\ * & * & * & * & 0 & 0 \\ * & * & * & * & * & 0 \end{pmatrix}$$

(17)

Let us note that as follows:

$$\tilde{S}^T(y(t))Z\tilde{S}(y(t)) \leq y^T(t)LZy(t), 2y^T(t)P(T_0 + \Delta T_0)\tilde{S}(y(t)) \leq 2y^T(t)P(T_0 + \Delta T_0)Ly(t)$$

(20)

Then we can get $\dot{V}(t) \leq \sum_{k=1}^K \zeta_k^T(t)\Pi_k\zeta_k(t)$, where

$$\Pi_k = \Upsilon_k + \tau_k F^T Q^{-1} F \quad (18)$$

$$\Upsilon_k = \begin{pmatrix} \Upsilon_{k11} & -\frac{2G}{K} + \frac{L}{K}(T_k + \Delta T_k) - M_1 + M_2^T & -\frac{2G}{K} + F_1^T - M_1 + M_3^T & M_4^T & M_5^T & M_6^T \\ * & -U - M_2 - M_2^T & -M_2 - M_3^T + F_2^T & M_4^T & M_5^T & M_6^T \\ * & * & -M_3 - M_3^T + F_3 + F_3^T & F_4 & F_5 & F_6 \\ * & * & * & * & * & * \\ * & * & * & * & * & * \\ * & * & * & * & * & * \end{pmatrix}$$

$$\Upsilon_{k11} = -P(C + \Delta C - KG) - (C + \Delta C - KG)^T P + \frac{2L}{K^2}(T_0 + \Delta T_0) + U + L^2 Z + M_1 + M_1^T$$

$$\text{Let } \Upsilon_k = \Sigma_k + \Omega_k, k = 1, 2, \dots, K$$

(19)

$$\Sigma_k = \begin{pmatrix} \Sigma_{k11} & -\frac{2G}{K} + \frac{L}{K}T_k - M_1 + M_2^T & \Upsilon_{k13} & M_4^T & M_5^T & M_6^T \\ * & \Upsilon_{k22} & \Upsilon_{k23} & -M_4^T & -M_5^T & -M_6^T \\ * & * & \Upsilon_{k33} & F_4 & F_5 & F_6 \\ * & * & * & \tau_k Q + R & 0 & 0 \\ * & * & * & * & -R & 0 \\ * & * & * & * & * & -Z \end{pmatrix}, \Omega_k = \begin{pmatrix} -P\Delta C - (\Delta C)^T P & \frac{L}{K}\Delta T_k & 0 & 0 & 0 & 0 \\ * & * & 0 & 0 & 0 & 0 \\ * & * & * & 0 & 0 & 0 \\ * & * & * & * & 0 & 0 \\ * & * & * & * & * & 0 \\ * & * & * & * & * & * \end{pmatrix}$$

$$\Sigma_{k11} = -P(C - KG) - (C - KG)^T P + \frac{2L}{K^2}T_0 + U + L^2 Z + M_1 + M_1^T + \frac{2L}{K^2}HFB_0,$$

$$[\Delta C, \Delta T_0, \dots, \Delta T_k] = HF[A, B_0, \dots, B_k], \Omega_{k11} = -P\Delta C - (\Delta C)^T P = -PHFA - A^T F^T H^T P,$$

If we want to get the following equation:

$$\Omega_k = \Omega_{1k} + \Omega_{2k} + \Omega_{3k} < 0$$

where

$$\Omega_k = \begin{pmatrix} PH \\ 0 \\ 0 \\ 0 \\ 0 \\ 0 \end{pmatrix} F[-A \ 0 \ 0 \ 0 \ 0 \ 0] \Omega_{2k} = \begin{pmatrix} -A^T \\ 0 \\ 0 \\ 0 \\ 0 \\ 0 \end{pmatrix} F^T[H^T P \ 0 \ 0 \ 0 \ 0 \ 0] \Omega_{3k} = \begin{pmatrix} H \\ 0 \\ 0 \\ 0 \\ 0 \\ 0 \end{pmatrix} F[\frac{L}{K}B_k \ 0 \ 0 \ 0 \ 0 \ 0]$$

$$\Omega_k = \tau_k \Omega_{1k} + \Omega_{2k} + nI_{6n^2 \times 6n^2} + \Omega_{3k} - nI_{6n^2 \times 6n^2} < 0,$$

and by Lemma 1, we can get that $\forall F^T F \leq I$, if and only if there is a constant $\varepsilon > 0$,

$$\text{diag}\{nI_{n \times n}, nI_{n \times n}, nI_{n \times n}, nI_{n \times n}, nI_{n \times n}, nI_{n \times n}\} + \varepsilon^{-1} \text{diag}\{-PHH^T P, 0, 0, 0, 0, 0\} + \varepsilon \text{diag}\{A^T A, 0, 0, 0, 0, 0\}$$

$$= \text{diag}\{nI_{n \times n} - \frac{1}{\varepsilon} PHH^T P + \varepsilon A^T A, nI_{n \times n}, nI_{n \times n}, nI_{n \times n}, nI_{n \times n}\} < 0$$

(21)

where

If we want to get $\Omega_{3k} - nI_{6n^2 \times 6n^2} < 0$, only if we

take proper constant n , then we can get as

$$\Sigma_k = \begin{pmatrix} \Sigma_{k11} & -\frac{2G}{K} + \frac{L}{K}T_k - M_1 + M_2^T & \Upsilon_{k13} & M_4^T & M_5^T & M_6^T \\ * & \Upsilon_{k22} & \Upsilon_{k23} & -M_4^T & -M_5^T & -M_6^T \\ * & * & \Upsilon_{k33} & F_4 & F_5 & F_6 \\ * & * & * & \tau_k Q + R & 0 & 0 \\ * & * & * & * & -R & 0 \\ * & * & * & * & * & -Z \end{pmatrix}, \Omega_k = \begin{pmatrix} -P\Delta C - (\Delta C)^T P & \frac{L}{K}\Delta T_k & 0 & 0 & 0 & 0 \\ * & * & 0 & 0 & 0 & 0 \\ * & * & * & 0 & 0 & 0 \\ * & * & * & * & 0 & 0 \\ * & * & * & * & * & 0 \\ * & * & * & * & * & 0 \end{pmatrix}$$

$$\Sigma_{k11} = -P(C - KG) - (C - KG)^T P + \frac{2L}{K^2}T_0 + U + L^2 Z + M_1 + M_1^T + \frac{2L}{K^2}HFB_0,$$

$$[\Delta C, \Delta T_0, \dots, \Delta T_k] = HF[A, B_0, \dots, B_k], \Omega_{k11} = -P\Delta C - (\Delta C)^T P = -PHFA - A^T F^T H^T P,$$

follows:

$$\text{diag}\{-nI_{n \times n} + \frac{L}{K}HFB_k, -nI_{n \times n}, -nI_{n \times n}, -nI_{n \times n}, -nI_{n \times n}, -nI_{n \times n}\} < 0 \quad (22)$$

By combing the (17), (18), (19), (20) and (21) we

can get as follows:

$$\tilde{Y}_k = \begin{bmatrix} \tilde{Y}_{k11} & -\frac{2G}{K} + \frac{L}{K}T_k - M_1 + M_2^T & -\frac{2G}{K} + F_1^T - M_1 + M_3^T & M_4^T & M_5^T & M_6^T & \\ * & -U - M_2 - M_2^T & -M_2 - M_3^T + F_2^T & -M_4^T & -M_5^T & -M_6^T & \\ * & * & -M_3 - M_3^T + F_3 + F_3^T & F_4 & F_5 & F_6 & \\ * & * & * & \tau_k Q + R & 0 & 0 & \\ * & * & * & * & -R & 0 & \\ * & * & * & * & * & -Z & \end{bmatrix} + \tau_k F^T Q^{-1} F < 0 \quad (23)$$

$$A = \begin{bmatrix} 0.1 & 0 \\ 0 & 0.5 \end{bmatrix}, B_0 = \begin{bmatrix} 0.2 & 0.3 \\ 0.1 & 0.1 \end{bmatrix}, B_1 = \begin{bmatrix} 0.2 & -0.3 \\ 0.1 & 0.1 \end{bmatrix}, B_2 = \begin{bmatrix} 0.2 & -0.03 \\ 0.01 & 0.01 \end{bmatrix}, H = \begin{bmatrix} 1.0 & 0.3 \\ 0.2 & 0 \end{bmatrix}, F(t) = \begin{bmatrix} \sin t & 0 \\ 0 & \sin t \end{bmatrix}$$

where

$$\tilde{Y}_{k11} = -P(C - KG) - (C - KG)^T P + \frac{2L}{K^2}T_0 + U + L^2Z + M_1 + M_1^T + \frac{2L}{K^2}HFB_0 - \frac{1}{\varepsilon}PHH^T P + \varepsilon A^T A + \frac{L}{K}HFB_k,$$

The linearization of $S(x(t))$ at the origin, we can get as follows

$$S_{eq} = \begin{bmatrix} 0.201 & 0 \\ 0 & 0.401 \end{bmatrix}, [\Delta C \ \Delta T_0 \ \Delta T_1 \ \Delta T_2] = HF[A \ B_0 \ B_1 \ B_2],$$

Application of Matlab in the LMI toolbox to solve the corresponding linear matrix inequalities can be learned, there are four definite matrix

$$P = \begin{bmatrix} 0.270 & -0.01 \\ -0.01 & 0.350 \end{bmatrix}, R = \begin{bmatrix} 1.103 & 0 \\ 0 & 1.07 \end{bmatrix}, Z = \begin{bmatrix} 1.101 & 0 \\ 0 & 1.067 \end{bmatrix}, Q = \begin{bmatrix} 1.103 & 0 \\ 0 & 1.067 \end{bmatrix}$$

and normal number of $\varepsilon = 1.165$, Such that (8) to set up, so system (1) of the equilibrium point $x = 0$,

For arbitrary bounded time-delay τ_k ($k = 1, 2$) is

global stable. We take the system's initial function is often valued function $\varphi(s) = [0.8, -0.4]^T$ and

$F(t) = I_2$, Numerical simulation diagram is as

follows:

If the following matrix

$$\tilde{Y}_k = \begin{bmatrix} \tilde{Y}_{k11} & \tilde{Y}_{k12} & \tilde{Y}_{k13} & M_4^T & M_5^T & M_6^T & F_1^T \\ * & \tilde{Y}_{k22} & \tilde{Y}_{k23} & -M_4^T & -M_5^T & -M_6^T & F_2^T \\ * & * & \tilde{Y}_{k33} & F_4 & F_5 & F_6 & F_3^T \\ * & * & * & \tau_k Q + R & 0 & 0 & F_4^T \\ * & * & * & * & -R & 0 & F_5^T \\ * & * & * & * & * & -Z & F_6^T \\ * & * & * & * & * & * & -\tau_k Q \end{bmatrix} < 0 \quad (24)$$

From(24) we can get as follows

$$\Pi_k = \tilde{Y}_k + \tau_k F^T Q^{-1} F < 0, \text{ then we can get}$$

$$\dot{V}(t) \leq \sum_{k=1}^K \zeta_k^T(t) \Pi_k \zeta_k(t) \leq 0, \text{ the proof is completed.}$$

4. Numerical Simulation

We will through the following numerical simulation of the system (1) to verify the validity of the theorem.1 At this point, only consider the case there are two time-delay, this time the system model as follows

$$\dot{x}(t) = -(C + \Delta C)x(t) + (T_0 + \Delta T_0)S(x(t)) + \sum_{k=1}^2 (T_k + \Delta T_k)S(x(t - \tau_k)) + I$$

where

$$C = \begin{bmatrix} 7.91 & 0 \\ 0 & 6.91 \end{bmatrix}, T_0 = \begin{bmatrix} 3.11 & 1.91 \\ 1.01 & 1.51 \end{bmatrix}, T_1 = \begin{bmatrix} 1.11 & 2.01 \\ 0.91 & 0.51 \end{bmatrix}, T_2 = \begin{bmatrix} 6.91 & 2.01 \\ 3.01 & 5.01 \end{bmatrix}$$

$$S(x(t)) = [\tanh(0.2x_1(t)), \tanh(0.4x_2(t))]^T$$

Fig.1 The system state diagram at (a)

$$\tau_1 = 0.3s, \tau_2 = 1.1s \quad (b) \tau_1 = 0.6s, \tau_2 = 1.0s$$

5. Conclusion

In this paper, the synchronization problem has been studied for no parameter perturbations of multi-delay Hopfield neural network. HNNs are

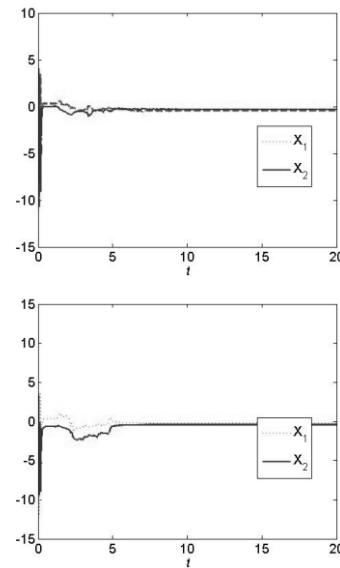

analyzed by constructing an appropriate Lyapunov-Krasovskii functional, given in a matrix condition based on global stability, and we give an example to verify the theorem of this paper.

References

- [1] Hopfield J J 1982 Neural networks and physical systems with emergent collective computational abilities. *Proceedings of the National Academy of Science of the USA* **79** 2554
- [2] Zhang J Y 2003 Global stability analysis in Hopfield neural networks. *Applied Mathematics Letters* **6** 925
- [3] Wang R L, Tang Z and Cao Q P 2002 A learning method in Hopfield neural network for combinatorial optimization problem. *Neurocomputing* **48** 1021
- [4] Dan S 1993 On the hysteresis and robustness of Hopfield neural networks. *IEEE Transactions on Circuits and System II: Analog and Digital Signal Processing* **11** 745
- [5] Liu D and Lu Z 1997 A new synthesis approach for feedback neural networks based on the perceptron training algorithm. *IEEE Transaction on Neural Networks* **12** 1468
- [6] Gopalsamy K and He X Z 1994 Stability in asymmetric Hopfield nets with transmission delays. *Physica D* **4** 344
- [7] YAN X P and LI W T 2007 Global asymptotic stability for Hopfield-type neural networks with diffusion effect. *Applied Mathematics and Mechanics* **28** 361
- [8] Z D Wang, Y R Liu and X H Liu, State estimation for jumping recurrent neural networks with discrete and distributed delays, *Neural Networks*. **22** (2009) 41-48
- [9] Ji C, Zhang H G 2005 Robust stability analysis of a class of Hopfield neural networks with multiple delays. *Lecture Notes in Science Computer* **3496** 209
- [10] Lou X Y and Cui B T 2007 Delay-dependent Criteria for Robust Stability of Uncertain Switched Hopfield Neural Networks. *International Journal of Automation and Computing* **3** 304
- [11] Gao K W, Chu W Y, Li H L, Liu Y P and Qiao L J 2004 Correspondence between hydrogen enhancing dezincification layer-induced stress and susceptibility to SCC of brass. *Phys. Lett. A* **2** 51
- [12] Liao X, Wonh K, Wu Z, Chen G 2001 Novel robust stability criteria for interval delayed Hopfield neural network. *IEEE Transactions on Circuits and Systems* **48** 1355
- [13] Di X, Liao X F and Shao J D 2007 A novel key agreement protocol based on chaotic maps. *Information Science* **15** 1136
- [14] Arik S 2000 On the global asymptotic stability of delayed cellular neural networks. *IEEE Transactions on Circuits and Systems- I: Fundamental Theory and Applications* **47** 571
- [15] Alonso H g, Mendonça T, Rocha P 2009 Hopfield neural networks for on-line parameter estimation. *Neural Networks* **4** 450
- [16] Boyd B, Ghaoui L E, Feron E and Balakrishnan V 1994 Linear Matrix Inequalities in Systems and Control Theory, *SIAM, Philadelphia*
- [17] Huang H and Gang F 2009 Synchronization of nonidentical chaotic neural networks with time delays. *Neural networks letter* **22** 869
- [18] Singh V 2004 Robust stability of cellular neural networks with delay: LMI approach. *IEEE Proceedings of Control Theory and Applications* **151** 125
- [19] Park H J, Kwon O M and Lee S M 2008 LMI optimization approach on stability for delayed neural networks of neutral-type. *Applied Mathematics and Computation* **196** 236

An Optical Neural Network Technique for Mining Frequent Maximal Itemsets in Large Databases

Divya Bhatnagar¹ and A. S. Saxena²

¹Jodhpur National University, School of Computer Applications,
 Jodhpur, Rajasthan-India

²Department of Computer Sc. & Engg., SRCEM
 Gwalior-India
 divyabbbb@yahoo.co.in

Abstract: This paper proposes an optical neural network model for mining maximal frequent patterns in large databases. The database is scanned only once and stored in the form of weight matrix as in neural networks. The frequent patterns are then mined from this weight matrix using optical inputs. This approach is extremely efficient for data mining in large databases, as the number of database scans is reduced to one and the support counts of the patterns are computed in parallel. It saves a lot of computational time as the optical multiplication is performed in few nanoseconds. This approach discovers the frequent patterns quickly and effectively mines the potential association rules. Appropriate techniques have been designed and performed to achieve this efficiency.

Keywords: Frequent itemsets, patterns, maximal itemsets, data mining, association rules, optical neural network.

1. Introduction

Data mining has been recognized as promising field of database research due to its wide and significant applications in industry. It is a key step in the knowledge discovery process in large databases [1]. It consists of applying data analysis and discovery algorithms that under limitation of acceptable computational efficiency, produce a particular enumeration of patterns over the data[2]. Due to massive amount of data generated from business transactions, there arose a need for an efficient techniques to discover new interesting patterns in less time from these large databases in order to derive knowledge for quick and effective decision making. One of the problems of data mining is to discover association rules from the database from which we need to determine frequent itemsets. The problems of finding these frequent itemsets are fundamental in data mining, and from the applications, fast implementations for solving the problems are needed[3]. Many algorithms have been implemented for finding frequent patterns for data mining. In large databases the problem of mining frequent patterns gets multifold, since the database needs to be scanned several times. One of the important development in area of association rule mining was development of Apriori [4] algorithm. It was improved by partition [5] and sampling [6], but both of these approaches were inefficient when

the database was dense. The use of optical neural network for mining frequent patterns with only a single database scan seems to be the most optimized technique. The parallel computation of frequent patterns makes mining faster. Traditional association rule algorithms adopt an iterative method to discovery, which requires very large calculations and a complicated transaction process[7]. This approach discovers the frequent itemsets by making use of the best features of optics and neural networks. It makes use of maximal pattern mining to save computational time and reduce the number of candidate generation. The maximal patterns are determined and used for further mining their frequent subsets.

2. Proposed Model

The model suggests for mining frequent maximal patterns using an optical neural network.

2.1 Neural Networks

Artificial neural networks are inspired by the operation of the human brain. It is a model of the biological neuron as a circuit component to perform computational tasks. The function of a neuron can be described in mathematical form with:

$$O = F \left(\sum_i w_i \cdot I_i \right)$$

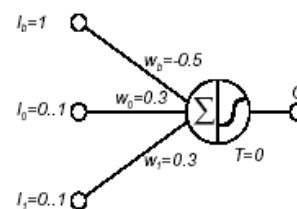

I_0	I_1	I_2	$\sum_i w_i I_i$	O
1	0	0	-0.5	0
1	0	1	-0.2	0
1	1	0	-0.2	0
1	1	1	0.1	1

where O is the output signal of the neuron and I_i are the input signals to the neuron, weighted with a factor w_i . F is some nonlinear function representing the threshold operation on the weighted sum of inputs.

Figure 1: A neural implementation of a logical AND function and the corresponding truth table including weighted sum of inputs of the neuron.

2.2 Optical Neural Networks

Optical Neural Network Optical neural networks interconnect neurons with light beams. No insulation is required between signal paths, the light rays pass through between each other without interlacing. The density of transmission path is limited only by the spacing of light sources, the effect of divergence and the spacing of detectors. As a result all signal paths operate simultaneously, which results in a true data rate[8]. The strengths of weights are stored in holograms with high density. These weights can be modified during operation to produce a fully adaptive system. The proposed model uses electro-optical matrix multipliers where optics is used for its massive parallelism and input and output data are defined in the electronic domain.

2.3 Electro-optical Matrix Multipliers

Theses nets provide a means for performing matrix multiplication in parallel. The network speed is limited only by the available electro-optical components. The computational time is potentially in the Nanosecond range[8]. Fig.2. shows the electro-optical vector matrix multiplier. The system is capable of multiplying a 5-element input vector by a 5 * 6 matrix, which produces 6-element NET vector. The column of light sources passes its rays through a lens, such that each light illuminates a single row of weight shield. The weight shield is a photographic film in which the transmittance of each square is proportional to the weight. There is another lens which focuses the light from each column of the shield to a corresponding photo detector. The NET is calculated by, $NET = \sum w_{ik} x_i$ where NET_k - NET, w_{ik} - weight from neuron i to neuron k, x_i - input vector component I. The output of each photo detector will represent the dot product between the input vector and the weight matrix. The set of outputs is a vector equal to the product of the input vector with weight matrix. Hence matrix multiplication is done in parallel. The speed is independent of the size of array. This makes the network to be scaled up without increasing the time required for computation. For weights, instead of photographic film, liquid crystal light valve may be used.

3. Mining Maximal frequent itemsets

In the suggested model, each transaction is represented by rows of the weight matrix and the presence and absence of any item is stored as weights 1 and 0 respectively. A sample database D and its corresponding weight matrix W is given.

D	
rid	Items
1	A C D F
2	B C E F
3	A B C E F
4	B E F

W					
A	B	C	D	E	F
1	0	1	1	0	1
0	1	1	0	1	1
1	1	1	0	1	1
0	1	0	0	1	1

5	A	B	C	E	F
---	---	---	---	---	---

1	1	1	0	1	1
---	---	---	---	---	---

Electro-optical implementation of the suggested model uses an array of light emitting diodes (LEDs) to represent the logic or neurons of the network. The array of LEDs represent the input vector, and an array of photodiodes (PD) is used to detect the output vector. Multiplication of the input vector by the matrix W is achieved by horizontal imaging and vertical smearing of the input vector that is displayed by the LEDs on the plane of the mask W. The output obtained is the net input to the neuron i.e., $NET = \sum w_{ik} x_i$. It is then thresholded and compared with the minimum support required for an item to be frequent. If the $NET \geq \text{min-sup}$, the item is frequent. In this way a single weight matrix can find all frequent-1 item sets in the database. The title of the paper is centered 17.8 mm (0.67") below the top of the page in 24 point font. Right below the title (separated by single line spacing) are the names of the authors. The font size for the authors is 11pt. Author affiliations shall be in 9 pt.

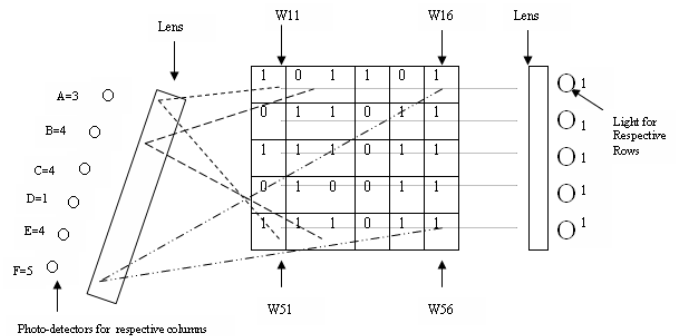

Fig.2. Electro-optical Vector Matrix Multiplier implementing a 5 by 6 matrix with weights as 0 or 1 indicating the presence or absence of an item in a transaction.

The proposed model goes through the following phases:

3.1. Transform database to weight matrix

The mined transaction database is D, with D having m transactions and n items. Let $T = \{T_1, T_2, \dots, T_m\}$ be the set of transactions and $I = \{I_1, I_2, \dots, I_n\}$ be the set of items. We set up a weight matrix $W_{m \times n}$, which has m rows and n columns. Scanning the transaction database D, if item I_j is in transaction T_i , where $1 \leq j \leq n, 1 \leq i \leq m$, the element value of W_{ij} is '1,' otherwise the value of W_{ij} is '0.'

3.2. Generate the set of frequent 1-itemsets

The weight matrix $W_{m \times n}$ is scanned and weight masks are set to 1 or 0. Initially to mine all frequent 1-itemsets, the input vector will consist of all 1s. This is because we need the product of w and x to be either 1 or 0 to represent presence or absence of the item. The sum of each column is read and compared with the minimum support. If it is found frequent it is stored in a list of frequent 1-itemsets F1.

3.3 Prune and join using apriori property.

Pruning means omitting infrequent items for further consideration. Only frequent items are joined to get candidate 2-itemsets. To do his, the corresponding values of the columns of frequent items in weight matrix are multiplied. Here 1×1 will only give the output as 1 which shows that both transactions contain that item

otherwise a 0 in any one or both transactions will give a 0 indicating that the item is not present in both the transactions. Thus, we get a matrix $A_{m \times q}$, where q is the number of candidate 2-itemsets.

3.4 Generate the set of frequent 2-itemsets.

The weight matrix $A_{m \times q}$ is scanned and weight masks are set. The input vector consisting of all 1s is fed. The sum of each column is read and compared with the minimum support. If it satisfies the minimum threshold the 2-itemset is frequent and added to the list of frequent 2-itemsets F_2 .

3.5. Generate candidate maximal itemsets from frequent 2-itemsets.

A frequent itemset P is maximal if P is included in no other frequent itemset[9]. All 2-itemsets that satisfy the criteria for joining are joined together to form a candidate maximal itemset. For example, $\{BC\}$, $\{BE\}$, and $\{BF\}$ can be joined to give a candidate maximal itemset, i.e., $\{BCEF\}$. All such itemsets are generated by joining all frequent 2-itemsets.

3.6. Mine frequent maximal itemsets from frequent 2-itemsets.

In order to mine frequent maximal itemsets, the candidate maximal itemsets are fed as input to the transpose of the initial weight matrix, i.e., $W_{m \times n}^T$ from which the column corresponding to the infrequent item is removed. Let us call this weight matrix as M . When a candidate maximal k -itemset is fed as input vector I_m , the output k received at each photo-detector shows the presence of that itemset in the transaction. If the output is not k , the candidate maximal itemset is not present in the transaction. Now, the total number of photo-detectors giving the output k is the support count of that candidate maximal k -itemset. The input vector for which the value of k is more than the threshold, i.e., min-sup, is frequent maximal itemset.

3.7. Mine all subsets of frequent maximal itemsets.

The other smaller itemsets are then mined from these frequent maximal itemsets.

4. Example

A

AB	AC	AE	AF	BC	BE	BF	CE	CF
0	1	0	1	0	0	0	0	1
0	0	0	0	1	1	1	1	1
1	1	1	1	1	1	1	1	1
0	0	0	0	0	1	1	0	0
1	1	1	1	1	1	1	1	1
Sum of columns								
2	3	2	3	3	4	4	3	4

F_2 is $\{AC\}$ $\{AF\}$, $\{BC\}$ $\{BE\}$ $\{BF\}$, and $\{CE\}$ $\{CF\}$. Candidate Maximal itemsets are $\{ACF\}$, and $\{BCEF\}$. Thus we get M as follows:
We feed $\{ACF\}$, i.e., 10101 as input M that contains rows corresponding to A, B, C, E, F.

Since $\{ACF\}$ is a 3-itemset, therefore, the expected

output from each column is not more than 3. Since $\{ACF\}$ is present in the first column indicating the first transaction, it gives the output $O_1 = 3$ for the first column. Since, the value for O_2 and O_5 is also 3, the number of transactions containing 3 are 3 which is equal to min-sup. Therefore, the maximal itemset $\{ACF\}$ is a frequent maximal itemset.

The same procedure can be repeated for other candidate maximal itemsets.

The other smaller itemsets can then be mined from these frequent maximal itemsets.

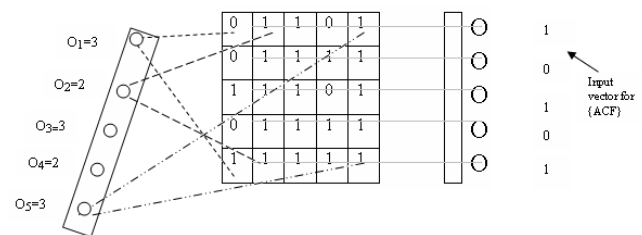

Figure 3: Electro-optical Vector Matrix Multiplier implementing a 5 by 5 matrix and input vector for the candidate itemset $\{ACF\}$.

5. Conclusion

In this paper, maximal frequent itemsets are mined using an optical neural network model. It stores all transaction data in bits, so it needs less memory space and can be applied to mining large databases. This model accesses the database only once to store the transaction-ids in the Electro-optical MVM and all supports are determined in parallel thus making it much faster than the other available techniques. This model can further be improved by replacing the electronic threshold by optical threshold. Optical thresholding maintains the spatial optical parallelism and avoids opto-electronic inter-conversions [10]. The 2-itemsets and higher can also be mined using the same model that will further reduce computation time. The model finds future scope in incremental data mining and online data stream mining.

References

- [1] Han, J., Kamber, M., "Data mining: *Concepts and Techniques*" Morgan Kaufmann Publishers, San Francisco (2001)
- [2] Fayyad U., Piatetsky-Shapiro G., Smyth P., and Uthuramy R (Eds.). "Advances in Knowledge Discovery and Data Mining" AAAI press, Menlo Park, CA, ISBN:0-262-56097-6, pages:611,1996.
- [3] Takeaki Uno, Masashi Kiyomi, Hiroki Arimura: LCM ver 2. Efficient mining algorithms for Frequent/ closed/ maximal itemsets.
- [4] Agrawal R. and Srikant R. : Fast algorithms for mining association rules in large databases. In Proc. 20th VLDB, pages 478-499, Sept. 1994.
- [5] Sarasere A., Omiecinsky E., and Navathe S. : An efficient algorithm for mining association rules in large databases. In Proc. 21st VLDB, pages 432-444, Sept. 1995.

- [6] Toivonen H. L sampling large databases for association mining rules . In Proc. 22nd VLDB, pages 134-145, Sept. 1996.
- [7] Hanbing Liu and Baisheng Wang: An association rule mining algorithm based on a Boolean matrix. Data Science Journal, Volume 6, Supplement, 9 September 2007.
- [8] Shivanandam, S. N., Sumathi, S., Deepa, S. N.: Introduction to Neural Network using MATLAB 6.0. TATA Mc.Graw Hill.
- [9] Takeaki Uno, Masashi Kiyomi, Hiroki Arimura: LCM ver 2. Efficient mining algorithms for Frequent/ closed/ maximal itemsets.
- [10] I. Saxena, P. Moerland, E. Fiesler, A.R. Pourzand, and N. Collings: An optical Thresholding Perceptron with Soft Optical Threshold.
- [11] Tenenbaum M., Augenstein M.J., Langsam Y. "Data Structures using C and C++" Prentice-Hall India, Edition 2.
- [12] Pujari A.K. "Data Mining: *Technique*" Universities Press.
- [13] Mos, Evert C. "Optical Neural Network based on Laser Diode Longitudinal Modes:.

posted written standpoints with at least one page (again only 1 team of 2 students occurred). During 3 weeks' time, 64 reviews have been carried out by the 26 electronics students on the web platform (see Figure 2, again comments by the lecturer directed to the students at the right-hand side of this assessment matrix).

This amounts to roughly 2.5 reviews per person, ranging from 0 to 7 reviews given and 0 to 4 received, of which all were useful for the game as all students gave points to their colleagues. Here 3 mutual assessments (diagonal lines in Figure 3) occurred despite their interdiction by the adapted rules, as mentioned above.

The average reward given in a review was 3.9 points (range from 3 to 5), the sum of rewards for papers (as a result of the 11 updated standpoints posted which is 42%) was 248, and the average sum of rewards received was 5.1. The sum of rewards for reviewers was 29 (collected by 14 persons = 54%, on average 2.1, range from 1 to 4, and corresponds to bold numbers inside the matrix). Also here the author has assessed all papers in the traditional way and written feedbacks for the sake of comparison with an earlier assessment method used in the years before (right section in Figure 3; points allocated by the lecturer in the box at right). In general, the quality of the standpoints was satisfying, the same applied to review and update activities.

3. Social implications of quality assessment

3.1 Combined assessment could target better

Of course one main interest of the present analysis is to check if the grades resulting from the system of SGC game rules approximates satisfyingly the qualitative assessment of the papers delivered by the students according to what was

to date evaluated by the trainer.

With this motivation in mind, a number of comparisons and correlations were undertaken with the rich material provided by the quantitative approach of allocating scores and numbers. The following figures have to be read in a way that any clear correlation would be extremely surprising in the fields of social science. All lectures mentioned in this paper were entitled "Technology Assessment" (TA) and included lectures of "Systems Dynamics and Biology" (SB). These lectures took place in the last year of a master's curriculum for students aged typically around 24 years and being on the edge to enter professional life.

Being a university trainer since 1997, the author has very well kept in mind the many shortfalls of traditional grading (Garfield, 1994, Anderson, 1998) of the "quality" of a paper such as dependence on mood, daytime, cohesion with the own opinion and sensibility or not to formalistic details or style. Additionally it appears as very likely that two or more trainers arrive at very different final marks, especially in subject matters like the present ones (Technology Assessment) with strong social components and with a mission to educate for democracy in the sense of John Dewey (IEW, 2011, Cybrary, 2011, Berding, 2000). With all that in mind it became easier for the author to shift the task of grading from the one trainer to the larger sample of students who on an average take some effort to view the paper from different perspectives.

For the author, the result of this approach is – initially hoped for only in the first year of such new system – a tremendous rise in time devoted to assessing and documenting authorship and reviewership.

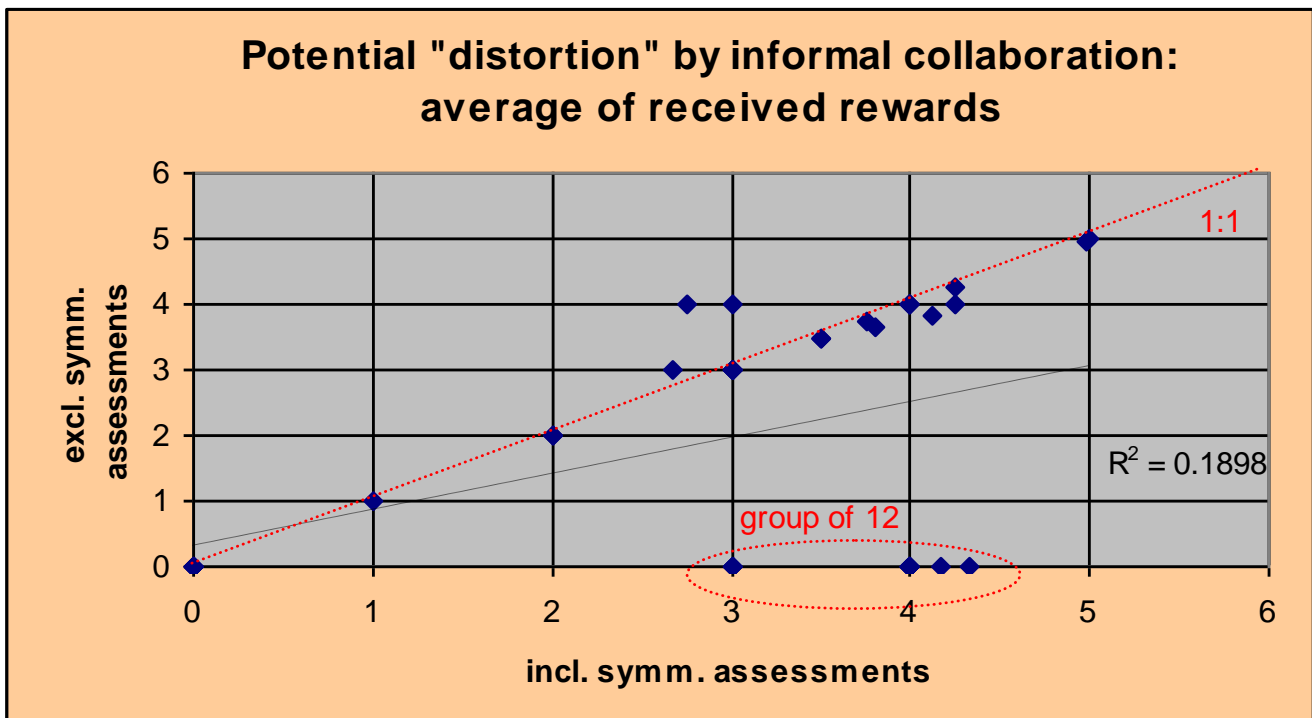

Figure 4: Effect of possibly strategically motivated "symmetric" review activities (i.e. making use of mutual assessment similar to a cartel) on the average grade of the standpoint posted in SGC level 2 by students in "construction engineering".

3.2 Construction students are watched when forming “informal subgroups”

As mentioned above, 12 out of the 46 construction students have based their harvest of points (finally meaning their mark in the lecture) on “symmetric assessments” (i.e. without such they would have received zero points in level 2, see encircled group of 12 in Figure 4 and green areas in Figure 1), three of whom belong to the distinct group of the collaborative five mentioned above.

But still it cannot be claimed for sure that the quality of their papers as assessed by the trainer would be weaker with these students. Similarly, final marks of this group are not substantially different. In the following analysis, such “symmetric assessments” are not excluded as a focused analysis has shown that the main picture and the conclusions are not altered by taking or leaving these symmetric assessments.

This incidence of “informal collaboration” gives rise to form three clusters of students [the mentioned colors are marked in Figure 1 and Figure 5]:

- such showing *no* “informal collaboration”, i.e. no “symmetric reviews” at all (i.e. not belonging to a subgroup that does mutual review in level 2) [white]
- such showing *additional* “informal collaboration”, i.e. reviewing both on their own and within said subgroups [light green]
- such showing *only* “informal collaboration”, i.e. not being active outside the subgroups with apparently agreed mutual aid for gaining rewards [green].

The following Figure 5 shows the average score for the single levels of SGC and the two quizzes (TA, SB) as a function of these three student clusters. The result *suggests that “informally collaborating” students* are not weaker than the average but on the contrary *are more successful in all levels than “single warriors”*. This result can be seen as *counterintuitive* compared with the classical rule “cheating is forbidden”.

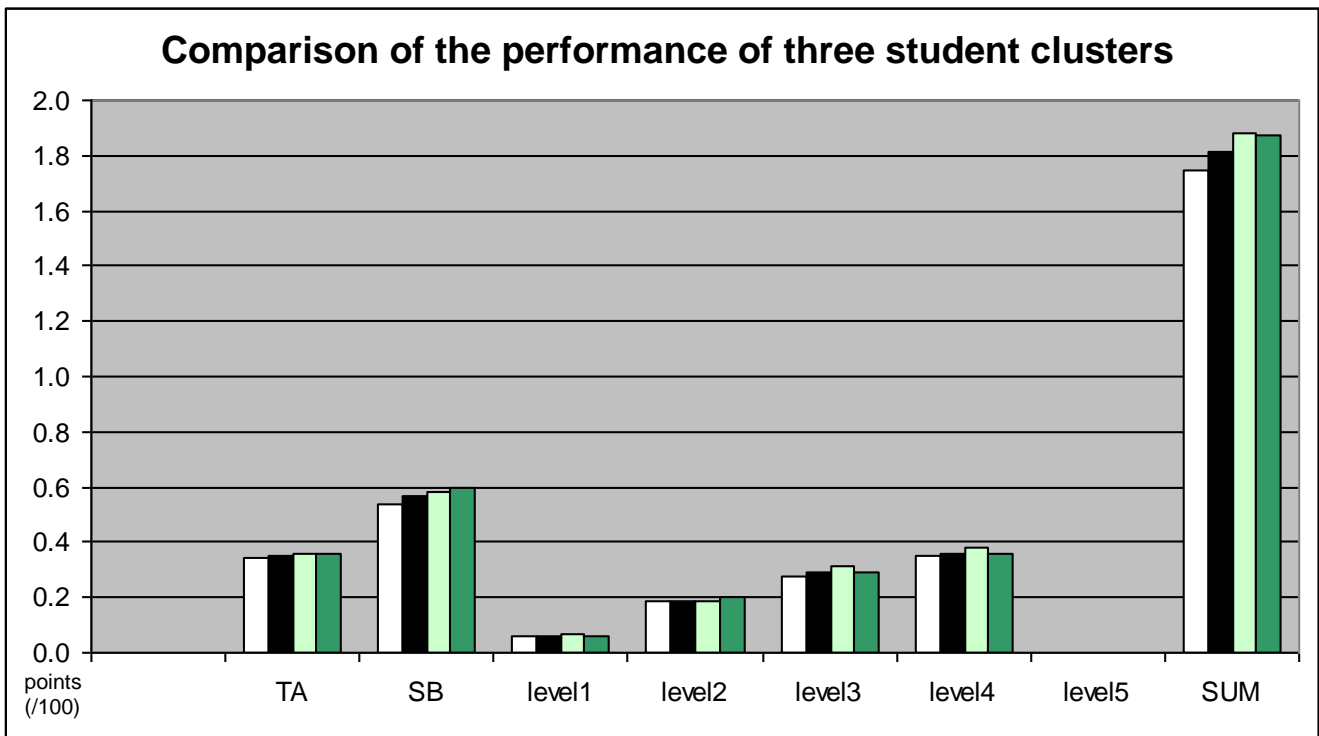

Figure 5: In this bar chart the average points achieved by students from three different clusters of behavior in SGC’s level 2 are exhibited (*no* “informal collaboration”, in white, *additional* “informal collaboration” in light green, *exclusive* “informal collaboration” in dark green and *total* of all students in black). However not significant, *data shows that best overall performance is achieved by students combining “own hard work” with “strategic action”* (light green bars), especially in the negotiation oriented and team-oriented levels 3 & 4 (but individual-oriented levels are best mastered by students relying only on “informal collaboration”). At any rate, “informal collaboration” (i.e. building social structures) does pay off!

4. Comparison of several methods for review quality assessment through correlations

4.1 How to construct a “true” measure for students’ performance as authors?

After such findings on the principal social implications of (any) academic assessment, several questions appear of relevance for the planned *composition of the metric* that should compose the mark in such a lecture, e.g.:

- include the rewards for reviews into the mark or

not? This has a positive effect on the social dynamic during the negotiation game but a still unclear effect on the fidelity of the score (compare left with right sides in both Figure 6 and Figure 7)

- take as score the sum of received points for authors’ quality (named “p”) as previously planned (in order to reward attractiveness of the theme and the article to reviewers) or rather the average points in order to exclude artifacts such as unequal attractiveness of a title attracting a different number of reviews?

(compare both parts of Figure 6 with both parts of Figure 7).

All of the correlations in Figure 6 and Figure 7 show an indiscernible correlation, the “average” method still being slightly better correlated than “sum” with “the trainer’s

review”. “Average” is chosen, mainly because the better theoretical foundations. The same applies to the inclusion of the rewards for reviewership (named “5-p”, see rules) that at least motivate for increased quality of review.

The choice finally made appears in dark yellow.

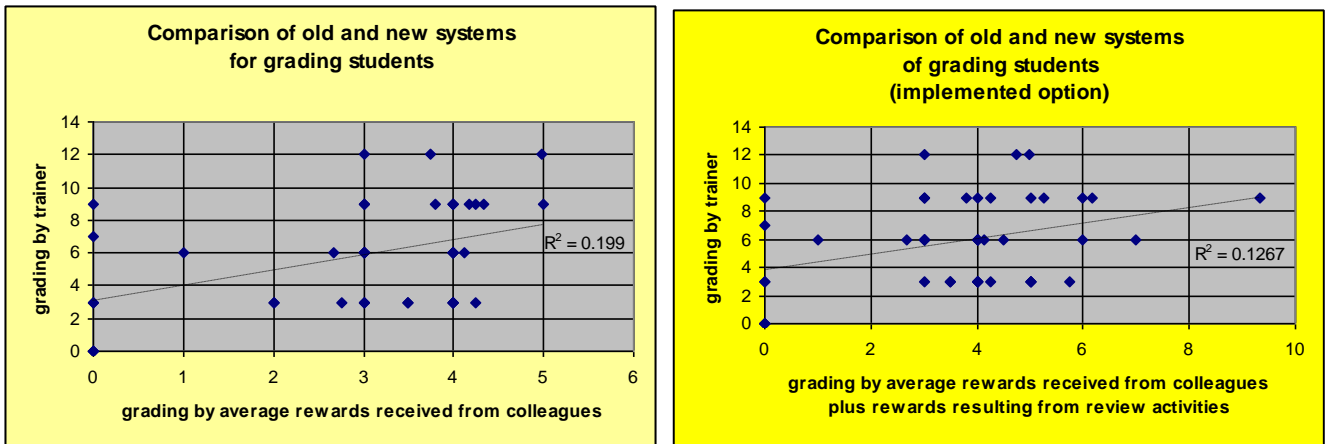

Figure 6: Analysis of grading through review activities (average of received rewards) in SGC’s level 2 by students in “construction engineering” with (right) and without (left) rewards for review activity. The final grading methodology was a combination of “average rewards received from colleagues plus rewards resulting from review activities” and “grading by trainer” which is shown in both axes on the dark yellow graph (right).

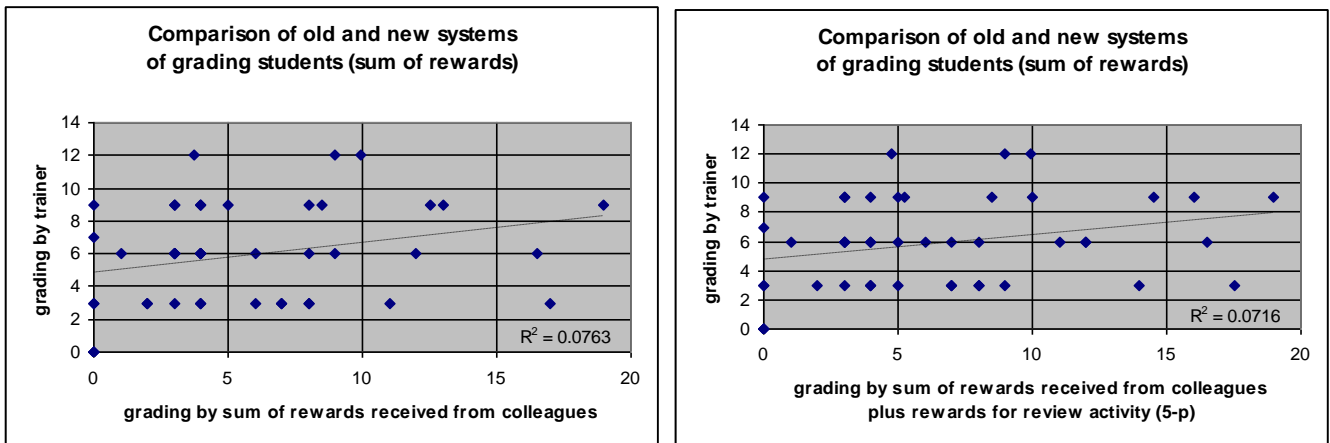

Figure 7: Analysis of grading through review activities (sum of received rewards) in level 2 by students in “construction engineering” with (right) and without (left) rewards for review activity. The only difference to Figure 6 is taking here “sum” instead of “average”.

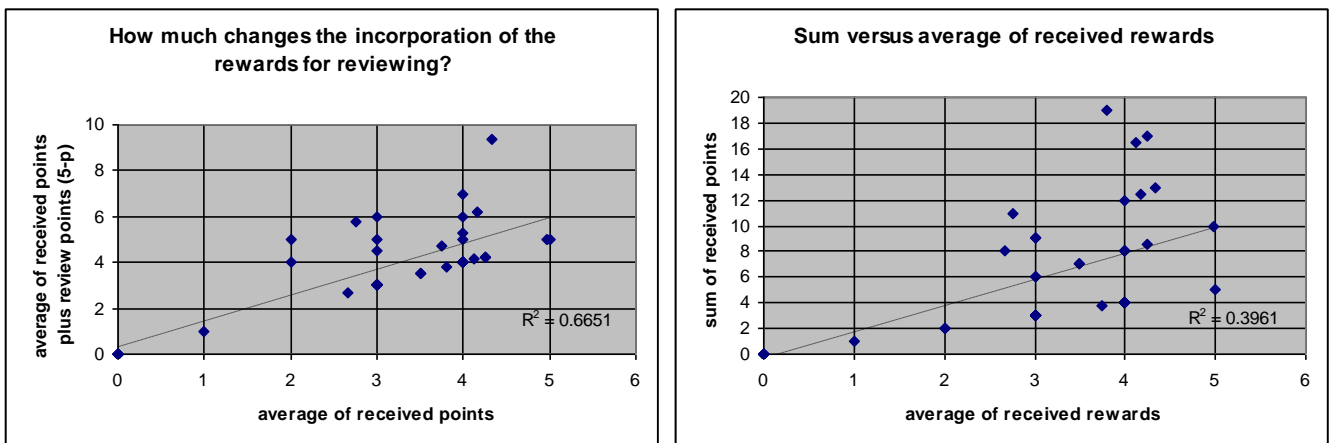

Figure 8: Comparison of both influences identified in Figure 6 and Figure 7: influence by received rewards (left) and by taking the average instead the sum (right) for the score. Sample: level 2 by students in “construction engineering”.

In the light of Figure 6 and Figure 8 (left) the following decision is made: even if inclusion of the review rewards does not enhance significance of correlation between rule's result and the trainer's assessment, this review reward is included because it adds positively to the game's dynamic.

Quite early when viewing these graphs (and their understandably low values of the correlation coefficient R^2) it becomes apparent that it would be inappropriate to search for an algorithm of measuring success that yields the same results as the teacher's grades. It is more appropriate to speak of "making a decision" for a new and at the same time statistically independent measure for qualifying student action. Selecting one out of these many alternatives for grading is therefore an "act of creation" that should not try to desperately lag behind the "real, just and fair" marks as distributed by the trainer until now.

In general it becomes clearly visible that both functionalities of game rules – namely "optimizing the pattern of social flow" and "creating a true picture of the students' competence" – do not necessarily always act in the same direction; very ideally both functionalities could be separated.

Still another source of data and hence assessment is offered by leaving out the actions of "symmetric review", practically by deleting the numbers in the grid elements encircled in green in Figure 1. The resulting subset of review actions could be interpreted as more inspired by the goal of academic quality than by the paradigm of pragmatic mutual support. Noticeable difference compared to the correlations undertaken for all reviews can be detected in the following cases:

- Figure 8 (left) where a higher correlation factor applies ($R^2 = 0.85$ instead of 0.66) pointing at higher corrective effect of the incorporation of rewards for review in the cases of "symmetric (i.e. pragmatic) reviews"; this diagnosis corresponds to expectation and intuition

- Similarly, Figure 8 (right) would show a higher R^2 of 0.6 which leads to the statement that students tending to relying on "symmetric assessment" would overproportionally profit from a measure "sum" as compared to "average"
- Figure 9 (right) where a higher correlation factor applies ($R^2 = 0.81$ instead of 0.54), in other words a lower correspondence of assessment by teacher versus by game rule; thus giving rise to higher credibility of the quality measure when resulting from non-pragmatic review actions. In other words: the additional action of "trainer's marks" is less necessary if students stick to the meaning of the rules and not only to the letter of the rules.

The above findings boil down to a diagnosis saying that "symmetric reviews" tend to correspond with pragmatic behavior trying to maximize received rewards while not focusing on the option to increase the quality of the papers as was initially intended by the SGC rules. In this respect, there is a certain tension to the result drawn from Figure 5 which might be slightly astonishing to an academically motivated personality.

4.2 What can be said about the act of reviewing and its "quality"?

The following graphs (overleaf) try to find out possible correlations between various students' inclinations and parameters such as:

- offering high average scores when reviewing (this is called being "generous" in the following figures)
- quantity and quality of students' reviews as assessed by the trainer by granting 0.1 points for each good review (being a "good reviewer")
- number of reviews a student has undertaken (being an "active reviewer")
- number of points a student has distributed in total when reviewing.

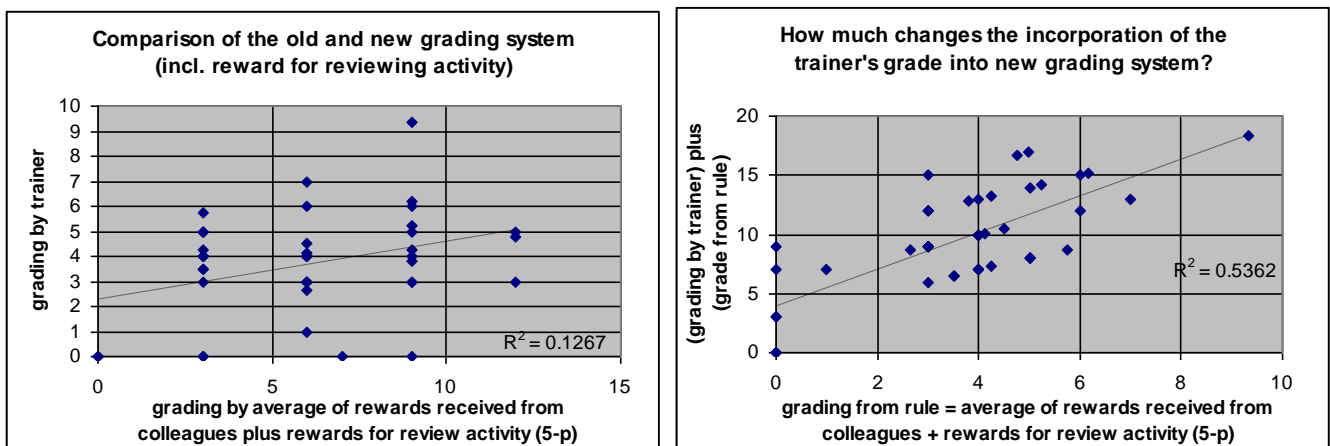

Figure 9: Comparison of the old and new systems of grading by students in "construction engineering" in level 2 of the negotiation game "Surfing Global Change": the two components finally chosen in correlation with each other (left) and the influence of inclusion of the trainer's score (right).

From these correlations, only a few show at least low significance (see correlation coefficients R^2 inside the figures), namely the following (enumerated below as list) regarding the entire class of construction students (insignificant correlations remain unmentioned). In some cases, R^2 without the “symmetric review activities” is added.

- Figure 10 (right): students reviewing more often tend to be reviewed more often (no correlation at all if without “informal collaboration”)
- Figure 10 (left): students distributing more points tend to receive more points (no correlation at all if without “informal collaboration”)
- Figure 13 (right), as concrete substantiation of the above item: students distributing more points rather tend to receive more reviews than tend to receive more average points (left). Both correlations are weaker if without “informal collaboration”, especially the first one ($R^2 = 0.005$ instead of $R^2 = 0.42$), thus underlining that one main characteristic for the “symmetric review” constitutes in “distributing more points and getting assessed more often by colleagues”
- Figure 11 (left): possibly papers that are well reviewed by students get reviewed more often (significantly higher correlation if without

“informal collaboration”: $R^2 = 0.62$) but this does not necessarily hold true if claimed for paper quality as reviewed by the trainer (Figure 12 left)

- Figure 12 (right): possibly papers from authors earning more as measured by game rules (= average rewards plus reviewer’s rewards) are likely to be reviewed more often (higher correlation if without “informal collaboration”: $R^2 = 0.5$).

Correlations of the mentioned type are rendered possible by the statistical material collected during the mentioned lectures and help to answer the questions in the following sub-headlines.

The available statistical material could even encourage an extensive interpretation such as: There are *two* (principally non-matching) *targets for behavior*: live formally up to the “rules” or live up to “ethics”.

4.3 How often is a student paper reviewed?

Figure 10 left shows a correlation showing that for students there seems to be a pay-off when reviewing in a more generous way (i.e. they are likely to receive more points). The graph at right shows that busy reviewers are assessed more often as authors.

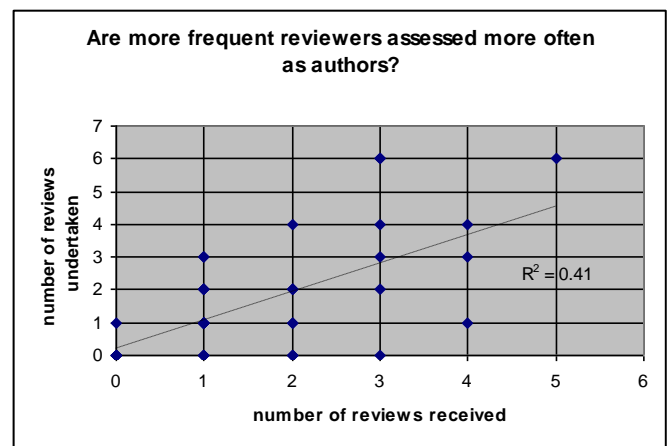
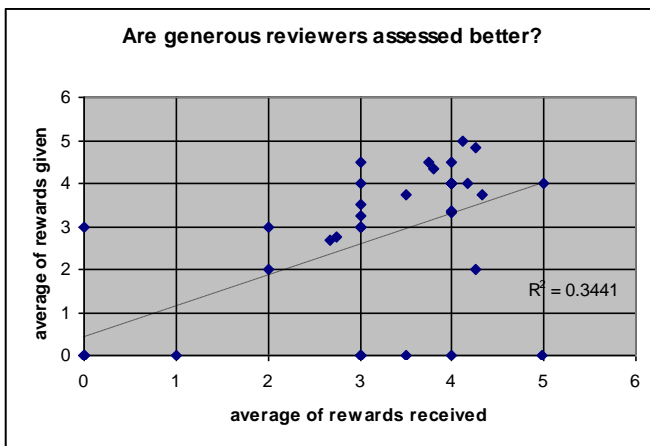

Figure 10: Two analyses in level 2 for students in “construction engineering” show: students distributing more points tend to receive more points (left) and students reviewing more often tend to be reviewed more often (right). This suggests a self-enhancing logical loop in social dynamics of level 2 generated by the game rules of “Surfing Global Change”.

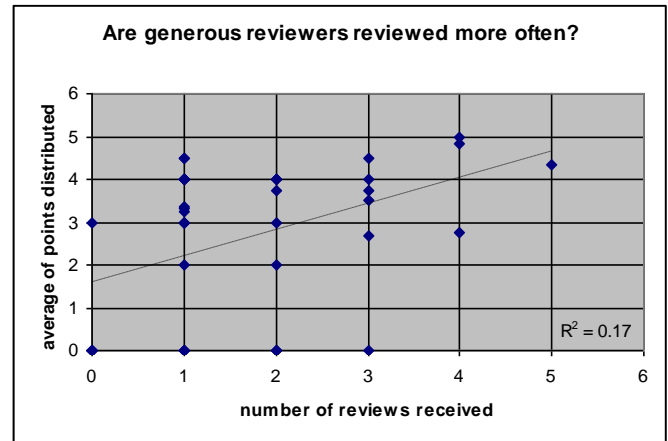
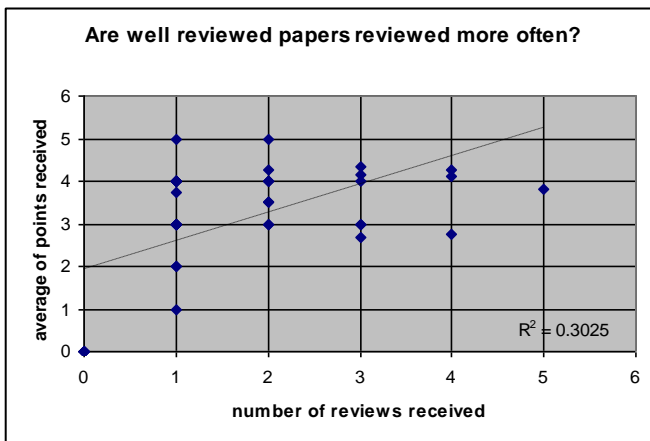

Figure 11: Double-check if often reviewed authors are rather receiving (left) or distributing (right) better average points shows an unclear picture despite a weak positive correlation in both cases (mainly left, seemingly with a saturation effect) in level 2 for students in “construction engineering”.

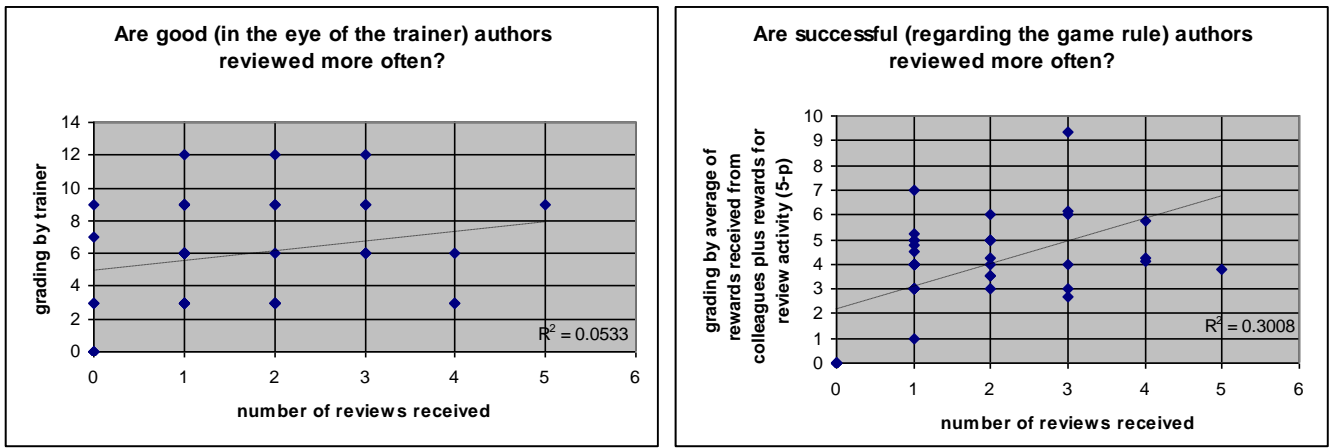

Figure 12: Possibly it could be said from Figure 11 (left) that better papers get reviewed more often. If “better papers” is measured by two other parameters it becomes visible that the correlation exists rather with “performance measured by the rules” than with “trainer’s assessment”, in the case of level 2 for students in “construction engineering”.

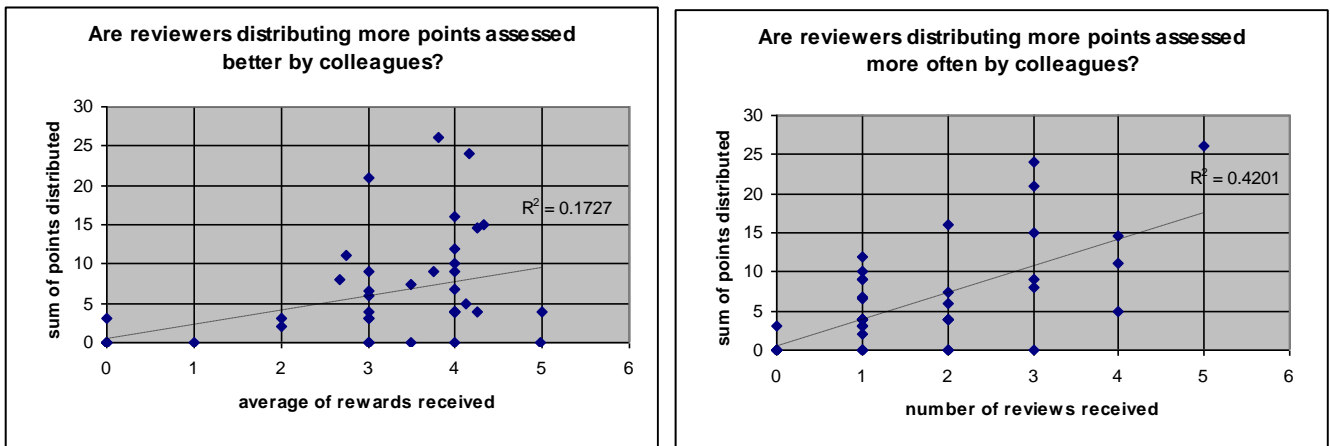

Figure 13: Double-check if students distributing more points (= average points distributed x number of reviews undertaken) tend to be reviewed rather better (left) or more often (right) in the case of level2 for students in “construction engineering”. Compare also with Figure 10

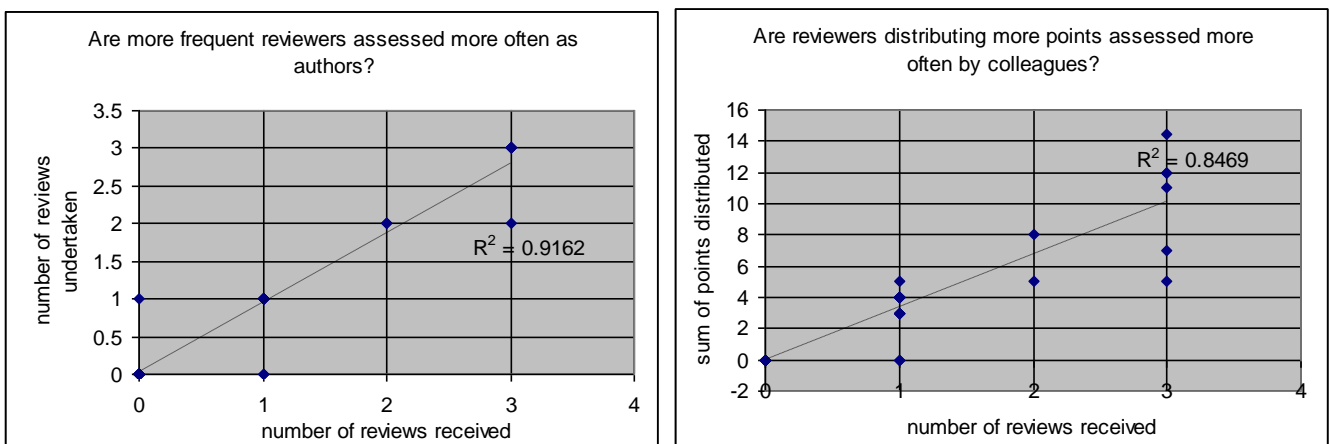

Figure 14: These two analyses in level 2 for students in “construction engineering” show most clearly that students reviewing more often and distributing more points tend to receive more points for their own papers. The left graph is identical with Figure 10 (right) and the right graph with Figure 13 (right) only that the data set is restricted to “symmetric reviews”

The meaningful information contained in the above ten figures would boil down to the following statements (in decreasing order of correlation coefficients) when quantitatively differentiating into the two main clusters of review activities:

1. among all twenty correlations (twice as much as performed both with and without symmetric reviews), the most striking relationship exists between “average of points received” and “number of reviews received” ($R^2 = 0.62$, see Figure 11 left, notably for the subset of non-pragmatically motivated reviews): *better papers get reviewed more often*. This means that papers that are perceived by students to have high quality attract potential reviewers. Possibly, students could surmise already beforehand how much they would value a paper. Clearly this constitutes a desired motivating effect which forms a desirable boundary condition for the entire review game in level 2. In brief, “quality attracts” insofar as the sense and meaning of the game is perceived as prevalent. In a climate of “targets count for quality”, the closest relationship appears with “perceived quality”
2. two correlations show a R^2 of about 0.42 (but now for the unselected set of all reviews):
 - more frequent reviewers are assessed more often as authors (see Figure 10 right)
 - reviewers distributing more points are assessed more often by colleagues (Figure 13 right).

Both relationships reveal that “frequent and generous reviewers collect more reviews” which apparently is caused by a previously agreed strategy of mutual aid. The proof is delivered by Figure 14 below which shows the correlations mentioned above for the subset of “symmetric reviews only” showing a correlation coefficient of $R^2 = 0.91$ and 0.85 respectively and Figure 15 (left). In a climate of “pragmatism counts”, the closest relationship appears with the motive of “mutual aid”.

4.4 What characterizes and motivates “symmetric reviews”?

Statistical analysis of both “clusters of review activities”, namely the symmetric and asymmetric ones, shed light on possible underlying motivation:

- (a) Both graphs in Figure 14 as well as the correlation for the subset of symmetric reviews of “average of rewards given” and average of rewards received” (Figure 15 left, $R^2 = 0.92$) reveal the underlying motivation of “mutual help” (i.e. a sort of pragmatism) which is valid only for these symmetric review activities. On the other hand, the asymmetric review activities show no correlation at all ($R^2 < 0.005$ in all three cases, e.g. Figure 15 right) which clearly shows that there is *no strategic behavior detectable for the “target oriented” review activities*.
- (b) Another striking correlation appears when plotting Figure 8 (left) for symmetric reviews only: $R^2 = 0.90$ shows that pragmatic approach exploits well the double advantage of review action taken: students already having high scores profit additionally from reviewer’s rewards.
- (c) The above understanding is corroborated when plotting Figure 13 (right) for symmetric reviews only ($R^2 = 0.85$): the high correlation coefficient shows that “successful authors are reviewed more often”, hence that *pragmatic behavior did really pay off well* in the framework of this game because a decisively high number of received reviews could be attained when selecting “strategic behavior”.
- (d) Similarly, when plotting Figure 12 (right) for symmetric reviews only, the comparatively slightly higher $R^2 = 0.59$ (as opposed to 0.50 for all reviews) could be taken as another sign that “successful authors get reviewed more often”. This underlines the *importance of high throughput of reviews for good results* (and not only ‘unread high-quality papers’!) and is well in harmony with the game outlay – and last but not least with reality.

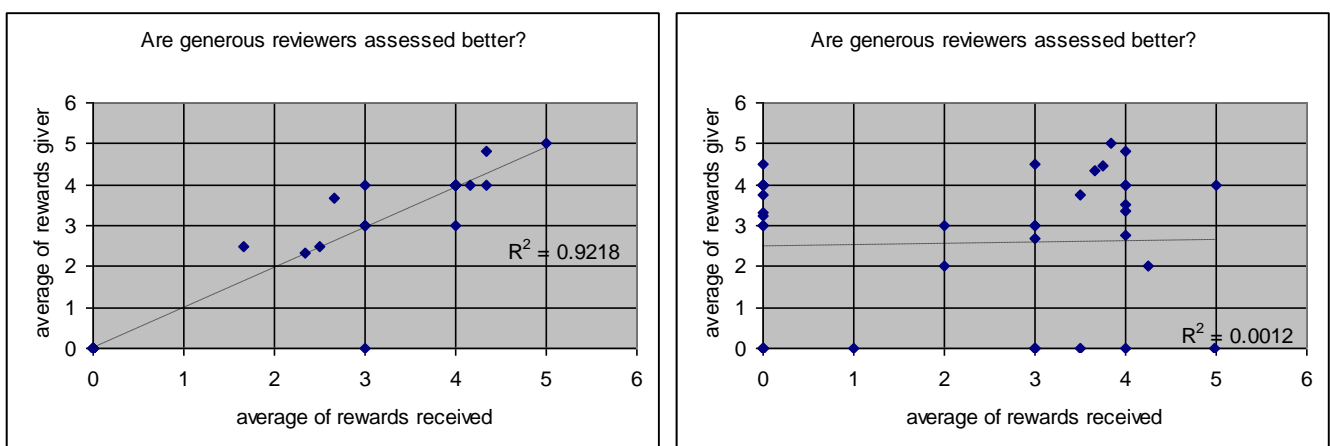

Figure 15: Comparison of the two clusters of activities which are clearly discernible: the correlation of the left side in Figure 10 performed only for “symmetric reviews” (left here) shows that most students received as much points as they gave ($R^2 = 0.92$, some failures occur even with pragmatism). The same type of plot performed only for asymmetric reviews shows no correlation at all ($R^2 = 0.00$, marks around or lower than 4 points were most popular). Again, these two analyses in level 2 stem from students in “construction engineering”.

Concluding from detected answers to the question in the above subtitle, student action (regarding the reviews undertaken) is clearly and *very distinctly falling apart* into

actions

- *either* motivated by pursuit of *game targets*

- or motivated by pursuit of own advantage.

From available data, there seems to exist *almost no sign for a mixture* of both motivations on the level of one single action. For a student as an individual, however, both approaches may well combine because everybody has numerous opportunities for single actions.

The decisive criterion for success in level 2 is not the mere 'high quality of a paper' but the high amount of human interaction triggered by – hopefully – high-quality papers. Isn't that academic life in a nutshell?

When suitably generalizing them, these analyses might deliver additional insights in the practice of academic life as well.

4.5 How many points does a student paper receive on average when being reviewed?

In principle, this question has already been answered on the previous pages but the following list gives a structured overview of correlations between “received rewards” and other available variables together with the respective correlation coefficient R^2 in brackets:

- sum of rewards distributed: see Figure 13 left (0.17)
- including versus excluding symmetric reviews: see Figure 4 in pink
- include “5-p” rewards for reviewing or not: see Figure 8 left (0.6)
- average rewards given (“collaborative syndrome”): see Figure 10 left (0.34, without symmetric reviews

0.0001 because no collaboration, only symmetric reviews 0.92; students of electronics 0.31 which is comparable)

- number of reviews received: see Figure 11 left (0.3) the best papers were those with only one to three reviews, worse those with none or more than three reviews received (“activity syndrome”)
- sum of points received: see Figure 8 right (0.4) which is obvious
- grades received from teacher: see Figure 6 left (0.2); this quite weak correlation indicates that the trainer’s and the student’s criteria for grading are quite *independent* from each other
- the correlation in Figure 16 (left) shows the influence of the possible option of taking the “sum” instead of “average” of received points (as was planned in the early stage of the making of SGC in order to produce a very high number of review activities) (0.38; $R^2 = 0.64$ much higher when symmetric reviews are left out which says that both measures are well correlated in case of non-pragmatic behavior)
- the correlation in Figure 16 (right) shows that “more active reviewers are assessed better” only for the subgroup of symmetric reviews which again underlines that a choice for a pragmatic strategy has occurred in this cluster (0.005 vs. 0.49).

These lectures on “Technology Assessment” and “Systems Analysis” *should educate for democracy through dialogue*. “Pragmatism” as a type of philosophy is independent from colloquial understanding of this word and has been dealt with by John Dewey, Richard Rorty (Berding, 2000, Haack, 2004, Cybrary, 2011).

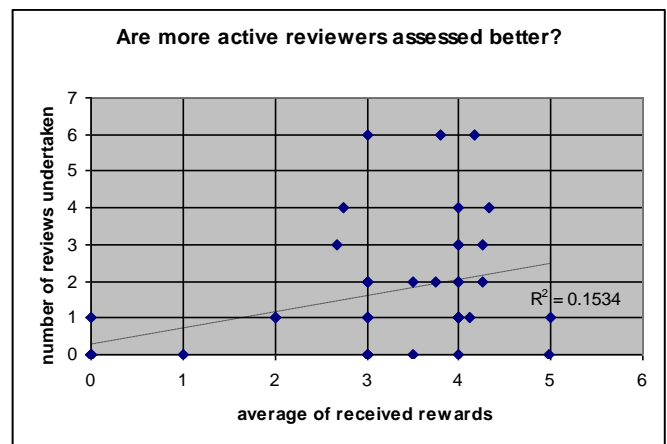
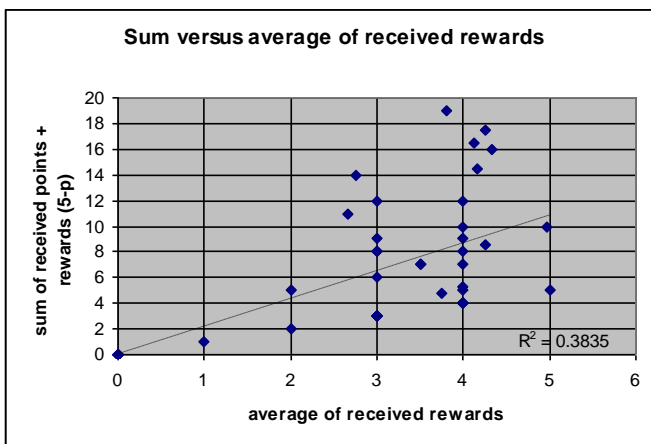

Figure 16: Two correlations with the average received points: at left with the sum of points received + “5-p” according to the rule; at right with the number of reviews undertaken. Data from level 2 for students in “construction engineering”

- The correlation in Figure 17 (left) appears astonishing at first sight: the less a reviewer gets rewards (5-p) the better (s)he appears as author. However, this combines well with the finding above

in Figure 15 saying “generous reviewers receive better rewards”, in other words “severe and restrictive reviewers receive weaker rewards”

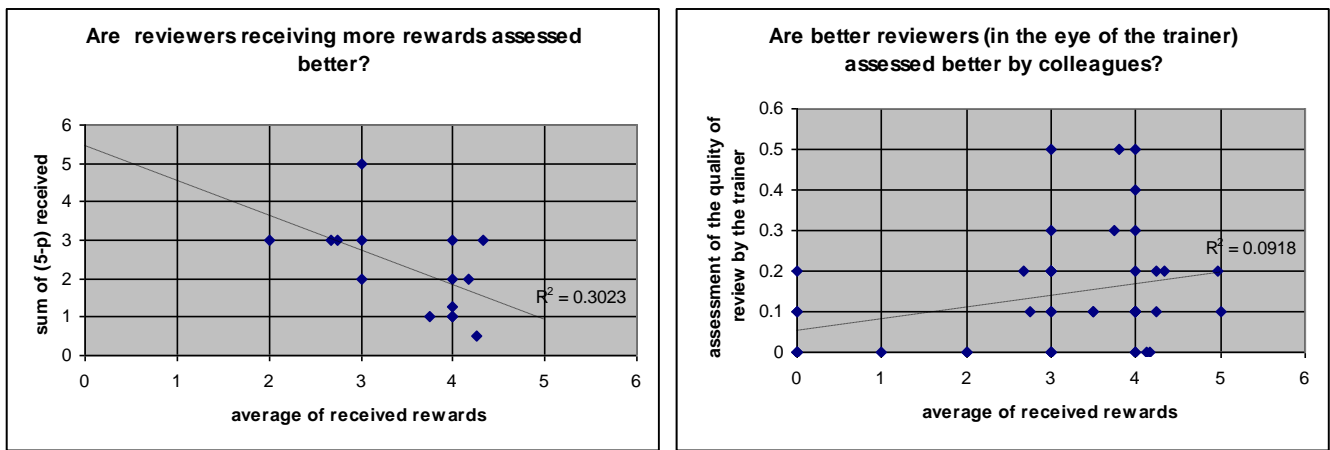

Figure 17: Two rather weak correlations with the average of received rewards, at left: the more severe a reviewer is, the better the same author is assessed as an author (in line with Figure 15). At right: low or no correlation with assessment of review quality by trainer) in the case of level2 for students in “construction engineering”

There appear to exist *two distinct strategies for success* (i) in the web-based negotiation game SGC (and possibly (ii) more generally in academia?):

1. gather rewards for reviewing
2. write good papers.

From the correlations mentioned above it can be seen that there seems to be an optimizing effort during such autopoietic systemic negotiation game.

The general impression arises: the assessment by the *trainer* appears to deliver results that are *quite independent* of the assessment by the *colleagues* and the result stemming from the game rules. The important question remains how such a discrepancy is caused and how it can be explained?

Figure 18 shows the three clusters of students in green, light green and white according to their degree of participation in symmetric review activities. Taking into account the observation that “white” students renounce to take part in “mutual aid” driven by two reasons, namely the spirit of “single warrior and lonely heroes” or blunt tremendously low level of any activity (too lazy to cheat), the observer might discern *four consecutive types of student activity*:

1. the “10% very good ones” in the understanding of the trainer who certainly work harder and deliver more elaborate results than the rest as a result of their own forces (leftmost column, only white)
2. two types of “fairly good ones” who either do or do not use additional help from collaboration (second and third columns, either green or white)
3. the type of pragmatically oriented ones who partly do use collaboration (fourth column, mixture, with more light green ones)
4. the type of very pragmatically oriented ones “minimum effort” who either only rely on mutual help without elevated own effort or who show too little initiative to take part in any system at all (fifth column).

It is not possible to simply match teacher-driven and rule-driven categorization. Only “the 10% best ones” or “teacher’s best choice” appears to fall into the non-symmetric reviewers group. However, the vast majority of the class applies a mixed strategy towards success inside a given set of rules. This bulk of the class seems to consist both of “quick checkers of the rules” and of “deliberate blenders of strategies”. – It should be noted that these last sentences are already strongly inferring speculations on the basis of pre-analytical visions.

The main issue here is: the web-based negotiation game “Surfing Global Change” (SGC) employs a method of grading that combines various skills and therefore does necessarily deliver different patterns of student grades as compared to traditional methods.

Overall, the important target of SGC is to **improve** students’ skills and academic capacities, not only to **monitor** them.

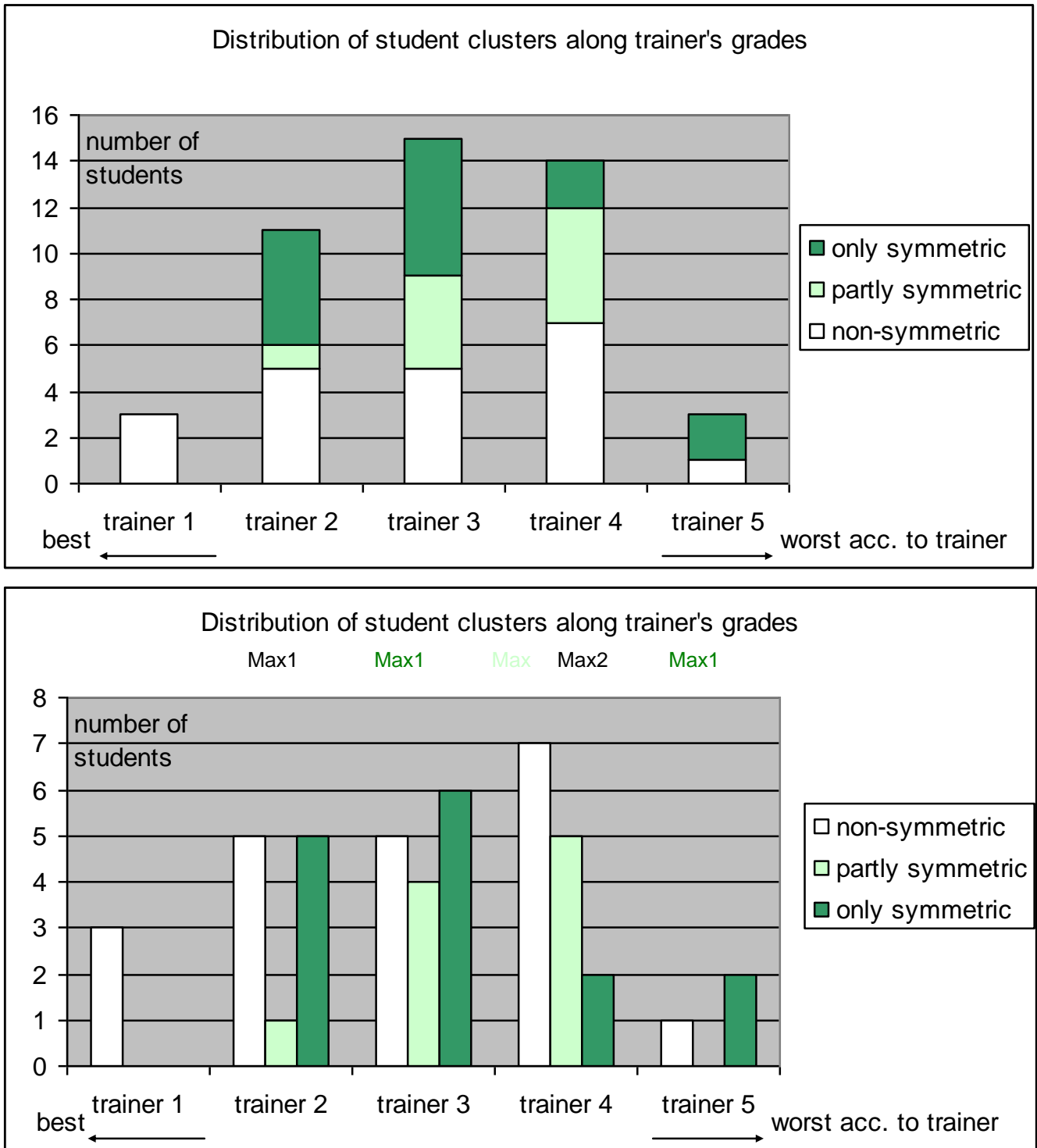

Figure 18: How do the three student clusters (defined by their participation in “symmetric review activities”) fall into the five categories of grades (for the level2 standpoint paper) distributed by the trainer? (above: cumulative, below: selective with maxima). Maxima of student distributions are marked in the respective colors (below). Data for “Surfing Global Change”, level 2 by students in “construction engineering”.

4.6 Does the trainer’s assessment of papers relate to anything?

In the form of a list, the following correlations could help to detect an answer:

- Still the best correlate is “average points received from colleagues” (0.20)

- R^2 falls when including the rewards for reviewing: (0.13) and still more when the sum instead of the average is considered

It can be concluded that *grading by the trainer is a rather isolated variable* (but could be seen as important as a corrective to the automatic result from rules).

Should the trainer wish to reconsider his grades in the light of the game's result? No, writing a paper is just one skill among many that are all of interest in academic performance!

It is always possible for a trainer to flexibly adapt the relative weight of his own assessment compared with the amount of rewards resulting from the rules. Given the experimental situation of the "first try" and the distortion by symmetric reviews in the case of "construction engineering" (BBM), more points were distributed by the trainer than by

the rule, whereas in the case of "industrial electronics" (IEL) with the *less pragmatic orientation of the students*, points from the teacher and from colleagues contributed the same, half of them was added from reviewers rewards (Figure 19).

Figure 20 illustrates the correlation and the differences resulting from whether or not adding the trainer's grade into the final method. It can be seen that an "independent variable" is added to the final grade (right).

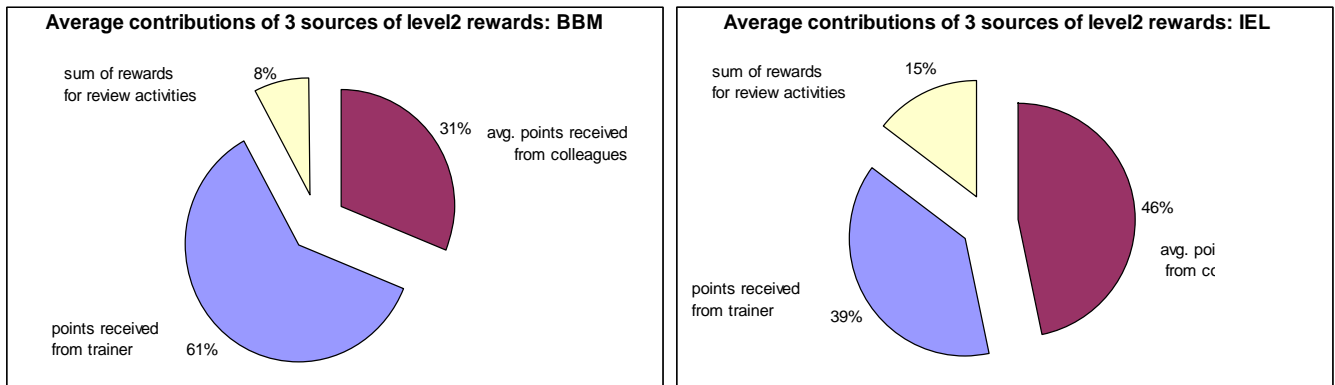

Figure 19: The contributions to overall level 2 points stem from teacher's assessment (light blue), from mutual assessment by colleagues (dark violet) and from rewards for review activities (yellow). The left figure is valid for construction students (BBM), the right figure for electronics students (IEL) at the same University for Applied Sciences (FHJ, 2011).

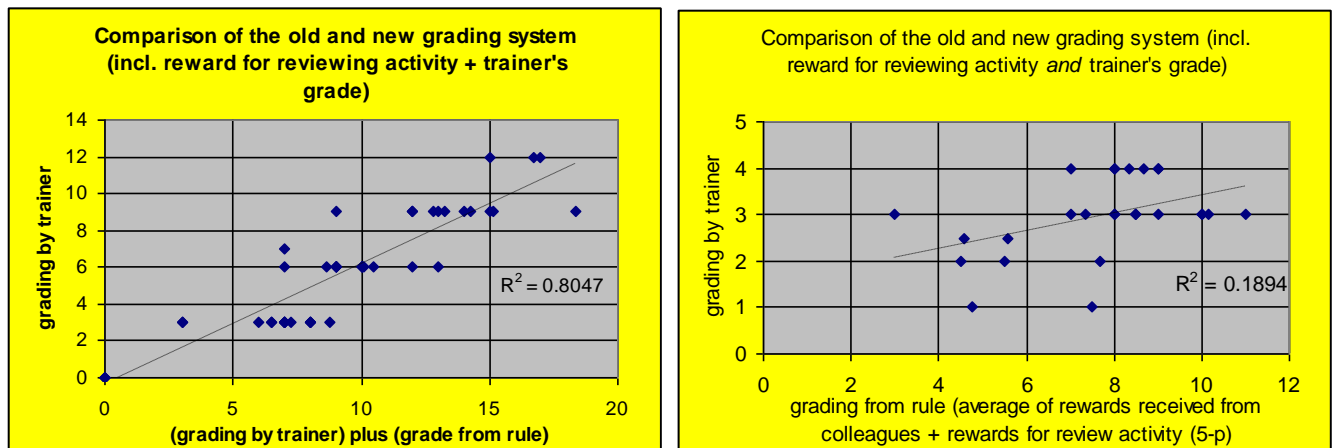

Figure 20: Correlation and the differences resulting from whether or not adding the trainer's grade into the final method complementing Figure 6 (right). Sample: students of construction engineering.

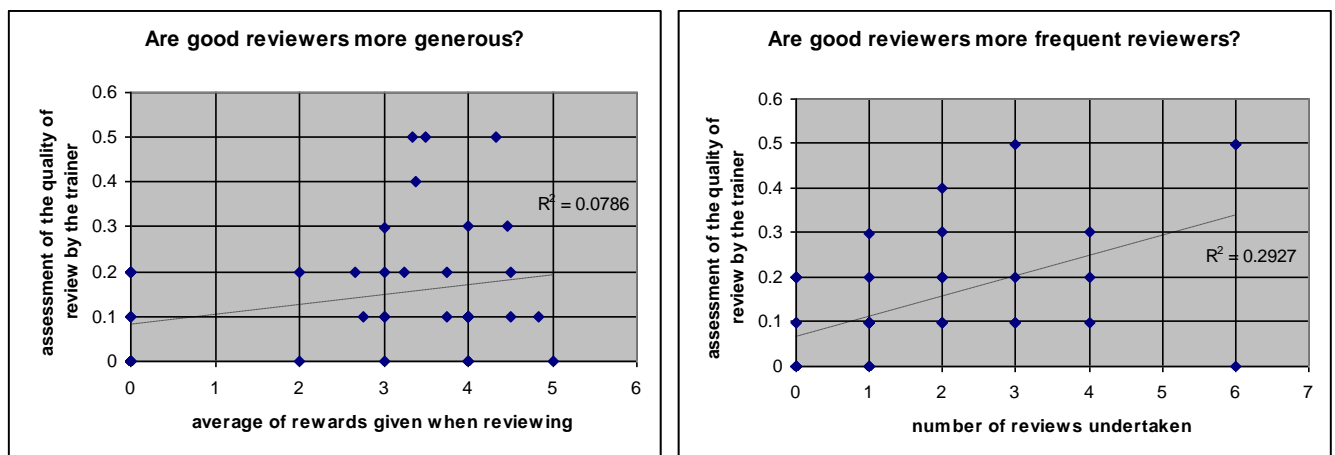

Figure 21: Comparison of the quality of review activities (as assessed by the trainer) with these reviewers' average scores granted (left) and with the number of standpoints reviewed (right) in level 2 by students in "construction engineering"

4.7 What relates to good assessment of review quality by the trainer?

Figure 21 shows that the quality of review activities as described by the trainer (0.1 points for each good review) is not sufficiently correlated to other variables, similarly there exists no possible correlation saying that good reviewers receive more rewards (without figure).

4.8 How much changes if the “symmetric reviews” are considered separately?

Viewing only the “symmetric reviews” of construction students (see in Figure 1 and as explained above and depicted in Figure 4) would change more or less slightly the diagnoses above, as already sometimes mentioned during the text. Additionally, in this following paragraph all such information is compiled.

A: The following statements apply much stronger for “only symmetric reviews”:

- The pay-off for students to be reviewed better when reviewing in a more generous way that is shown in Figure 10 (left) is much higher for “symmetric reviewers”

- students reviewing more often tend to be reviewed more often (Figure 10 right)
- students distributing more points tend to be reviewed more often and rather better (Figure 13 left and right).

B: On the contrary, the following statements are true to a higher extent for the “non-symmetric reviews”:

- from Figure 11 (left) that better papers get reviewed more often
- very clearly there is no link between
 - number of received rewards and distributed average rewards (compare Figure 13 right)
 - number of assessments received and number of assessments delivered (compare Figure 10 right)

which can be explained by the apparent absence of a strategy

- similarly, generous reviewers are not assessed better by colleagues (compare Figure 10 left).

Finding A might encourage to “pragmatic generosity” and finding B might describe *uncorrupted strive for quality*.

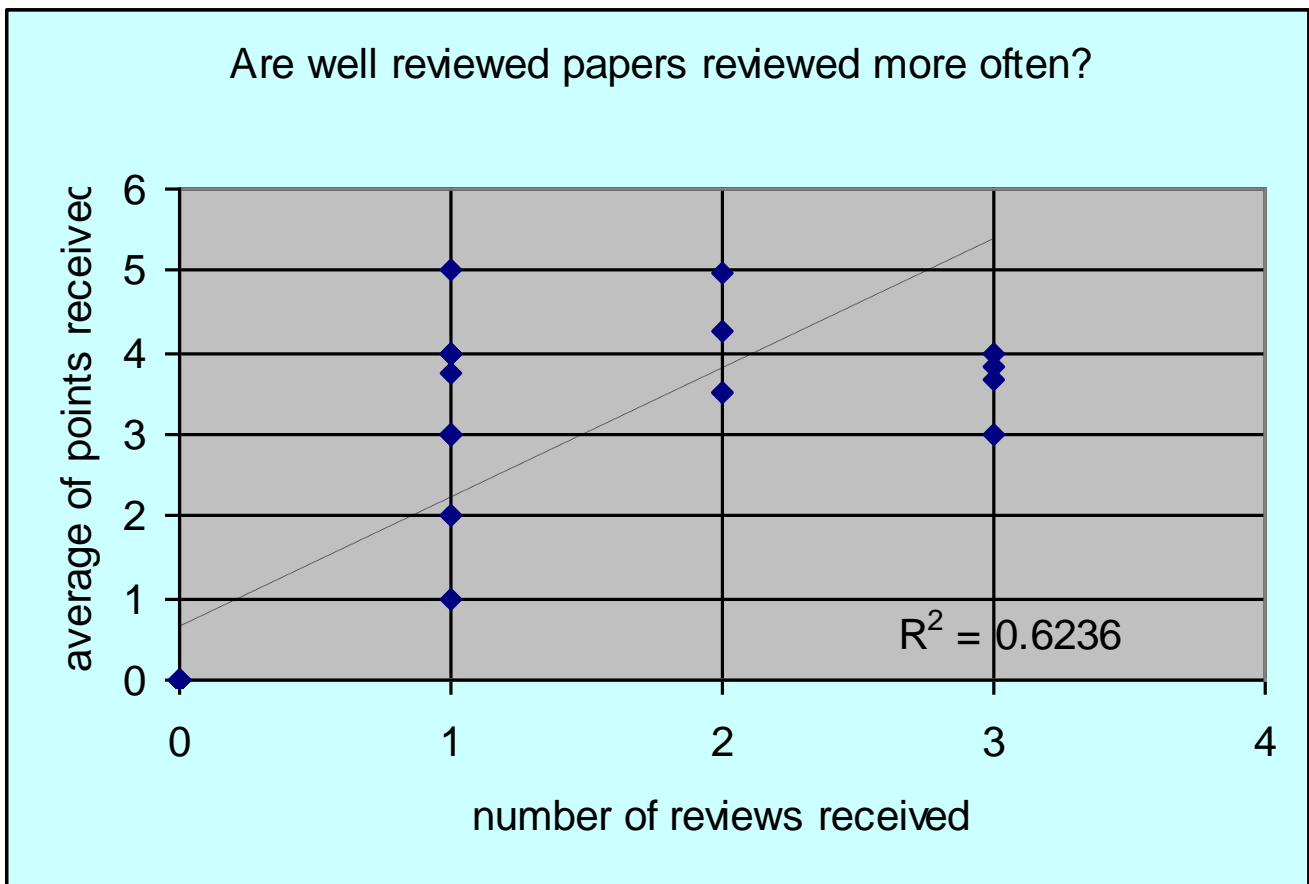

Figure 22: A clear correlation between the number of received reviews and the points received exists in level 2 for non-symmetric reviewers in students of “construction engineering”: Papers that are positively reviewed are reviewed more often.

Some very detailed and additional results regarding the correlations (to be compared with the total of BBM students described on the following pages):

- students relying on “informal collaboration” (green) show more significant but negative correlation of

results in level 1 (= traditional individual exam necessitating hard work) with level 2 (= review, a dialogue-oriented activity)

- students renouncing “informal collaboration” (white) show more significant correlation of results

in level 1 (= traditional exam) with level 3 (= a discussion prepared by a long paper, also needing hard work) as well as in level 2.

4.9 Are students of “electronic engineering” behaving differently?

In general, students of “*industrial electronics*” (IEL) show the following picture:

- *higher density of review processes* (2.5/student)
- almost *no* symmetric reviews given the fact that were interdicted (only three green lines in Figure 3)
- also no detectable “circles of reviews” including more than 2 partners as shown by a thorough analysis, hence stochastic review activities not determined by apparent strategies.

The above correlations were evaluated for students of electronic engineering which yielded:

- no correlation between grading through review activities and by the trainer (Figure 23)
- a characteristic result for the correlation analogous to Figure 9 (right) with $R^2 = 0.81$ (instead of 0.54) saying that there is no principal change in review assessment when incorporating the trainer’s points which only to a small part is explained by the fact that there was lower weight of trainer’s points for electronic students (Figure 19).

- Clearly it is *not* the case that
 - busy reviewers get assessed more often as authors (compare to Figure 10 right, $R^2 = 0.02$ instead of 0.41)
 - well reviewed papers get reviewed more often (in analogy to Figure 11 left, $R^2 = 0.11$ instead of 0.35)
 - successful authors are reviewed more often (analogously to Figure 12 right, $R^2 = 0.04$ instead of 0.30)
 - reviewers distributing more points are reviewed more often (analogously to Figure 13 right, $R^2 = 0.01$ instead of 0.42)
 - reviewers receiving more rewards are assessed better (analogously to Figure 17 left, $R^2 = 0.05$ instead of 0.30)

These five sub-points lead to the strong impression that *for electronics students there appears to exist no such elaborate system of mutual aid as for construction students.*

Such experimental finding is well in line with the general impression of the two professional disciplines and with their reported inclination towards forming cartels in practical economy.

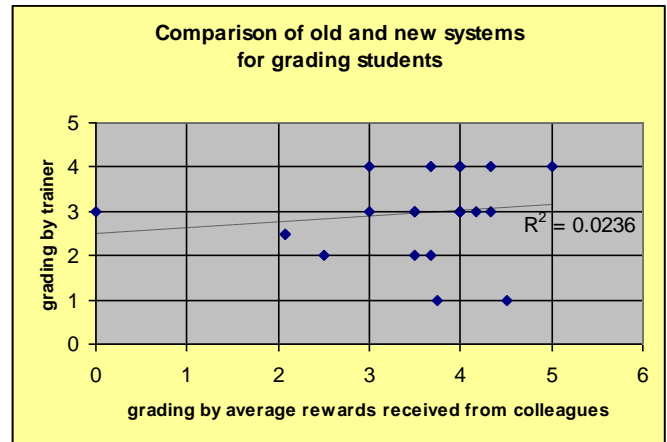
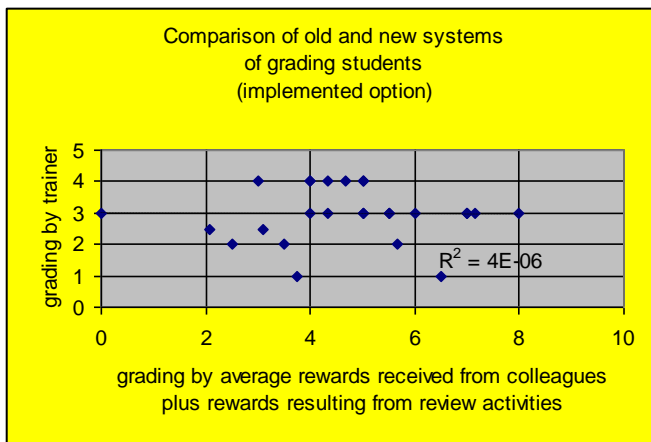

Figure 23: Analysis of grading through review activities (average of received rewards) in SGC level 2 by students in “electronic engineering”.

4.10 Comparison of SGC level 2 results with other skills

A slightly positive correlation (Figure 24) exists between level 2 results and

- a traditional quiz (SB) checking knowledge
- the controversial discussion in level 3 (especially for electronics students)
- the consensus-oriented discussion in level 4.

Both level 3 and level 4 are dialogue-oriented and focus on social skills.

A slightly negative correlation exists with

- a traditional quiz (TA) checking knowledge, for construction and electronics students respectively.

Both quizzes are focused on learning and understanding the content.

The overall picture shows that two main groups of levels (i.e. skills) might be conceived on the basis of these existing but weak correlations): *the discussion-oriented ones and the content oriented ones.*

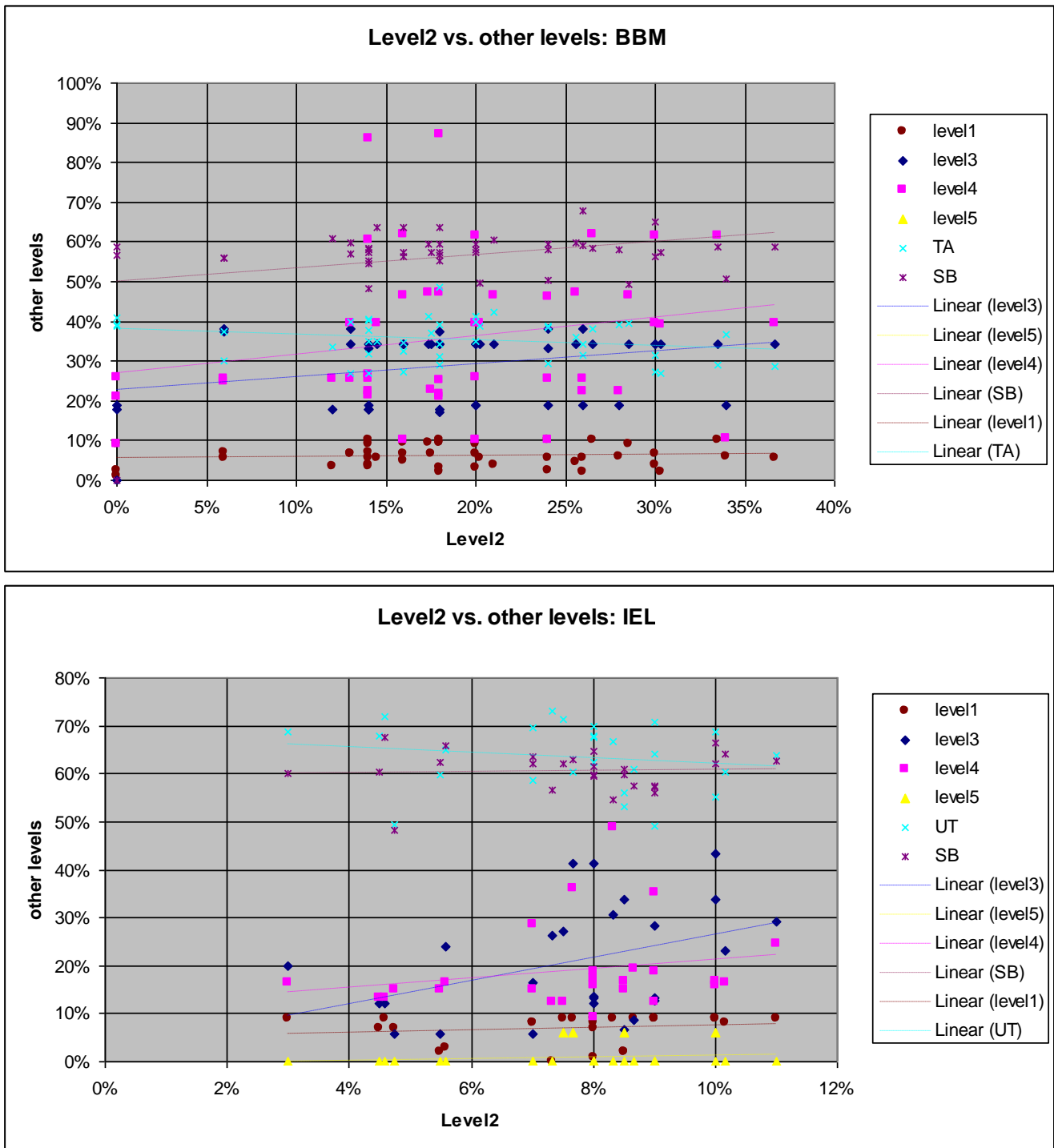

Figure 24: Connection between success in level 2 and other different levels for students in (BBM) and electronic engineering (IEL). Interestingly, there is a slight inverse correlation with the first written exam in both classes (TA, UT) and a slight direct correlation with level 3 in both classes, hence level2 & level3 could measure a similar mix of skills.

5. Conclusions from all correlations

The following chapter will sum up the above analyses and findings in an aggregated manner in the following sentences and will draw conclusions.

Table 1 shows the aggregated statistical results differentiated into construction students (left column) and electronics students (right column).

The differentiation into students with or without “symmetric review” strategies (first line) was done only for construction students, because this group was minimal with electronics students (second line). The *number of reviews*

per student was significantly higher for electronics students as compared to construction students (2.5 vs. 1.6, third line). Electronics students were slightly *more generous when distributing points* (+0.2 points on an average) and more *diligent with improving* their papers after review which was a facultative task (3% more updates, fifth line). A significantly higher score of electronics students receiving rewards for reviews (+24%, sixth line) completes this picture of *more enthusiastic attitude towards work-intensive activities in this discipline related to Information Technologies*.

Table 1: Aggregated statistical results for level 2 of the web based negotiation game “Surfing Global Change” (SGC) applying for all samples of students (all construction and electronics students)

Aggregated value	Result for students of “construction management”	Result for students of “industrial electronics”
Class size (using only/some/no symmetric reviews)	46 (15/10/21)	26
Total of reviews carried out (of which symmetric reviews)	90 (18 = 39%)	64 (3 = 0.05%)
Reviews per student	1.6	2.5
Average points distributed	3.7	3.9
Percentage of papers updated	39%	42%
Percentage of students receiving rewards for reviewing	30%	54%
Average reviewer’s rewards received in case of review activities	2.1	2.1

Table 2 shows that

- often reviewed papers get significantly more points
- altogether frequent and generous reviewers collect more reviews.

Table 2: Aggregated correlation results for SGC level 2 applying for all samples of students (both construction and electronics students)

Criterion	Correlated with
Number of reviews received as author	<ul style="list-style-type: none"> • Points received as author • Number of reviews undertaken
Points received as author	<ul style="list-style-type: none"> • Number of points distributed • Number of reviews received as author • NOT correlated with: points received from trainer

Table 3 differentiates between two sub-samples of students and shows two facts, namely

1. well assessed “non-symmetric” (i.e. non-pragmatic) reviewers review more other papers (Figure 22) (= “busy reviewers are assessed slightly better”) but “symmetric” (i.e. pragmatic) reviewers distributing more points are reviewed more often (“generous reviewers get reviewed more often”)
2. that the following two sentences are highly applicable only for “symmetric reviewers”, but not at all applicable for “non-symmetric reviewers”:
 - more often reviewed authors review more often (= “busy reviewers get reviewed more often”)
 - better reviewed authors distribute more points (= “generous reviewers are assessed better”).

These results might suggest that (if ever SGC draws a sufficiently true picture of real life) *a mixed strategy of combining limited symmetric (~ pragmatic) and non-symmetric (~ idealistic) behavior promises best results;* whereas relying on only one out of these two strategies might promise less success.

Table 3: Aggregated results for Surfing Global Change (SGC) level 2 applying differently for different sub-samples of construction students based on the correlation exercises. Legend: symmetric (~ pragmatic), non-symmetric (~ idealistic) behavior.

Fact no.	Subset of BBM students	Criterion for BBM (only non-symmetric)	Is correlated with
1.	non-symmetric	points received	• number of reviews received ($R^2 = 0.62$)
1.	symmetric	number of reviews received	• points distributed ($R^2 = 0.52$)
Fact no.	Subset of BBM students	Criterion for BBM (only non-symmetric)	Is NOT correlated with
2.	non-symmetric	points received	• points distributed ($R^2 = 0.00$)
2.	non-symmetric	number of reviews received	• number of reviews undertaken ($R^2 = 0.00$)
		Criterion for BBM (only symmetric)	Is correlated with
2.	symmetric	points received	• points distributed ($R^2 = 0.92$)
2.	symmetric	number of reviews received	• number of reviews undertaken ($R^2 = 0.92$) • (points distributed, $R^2 = 0.86$)

The two following tables are a logical extract of Table 3.

Fact no. 2 reveals the guiding motivation for both subsets for two types of action (how many reviews made and how many points distributed), see Table 4:

Table 4: Guiding motivation for the two subsets (“symmetric” and “non-symmetric”) reviewers for their actions (what they give)

<i>Fact no. 2</i>	<i>symmetric reviewers</i>	<i>non-symmetric reviewers</i>
How many reviews do I perform?	<ul style="list-style-type: none"> • certainly the more I receive 	<ul style="list-style-type: none"> • I don't care how many I receive
How many points do I distribute?	<ul style="list-style-type: none"> • certainly the more I receive 	<ul style="list-style-type: none"> • I don't care how many I receive

Fact no. 1 reveals the main expectation for both subsets for two types of reception (how many reviews received and how many points received), see Table 5:

Table 5: Guiding expectation for the two subsets (“symmetric” and “non-symmetric”) reviewers for their receptions (what they receive)

<i>Fact no. 1</i>	<i>symmetric reviewers</i>	<i>non-symmetric reviewers</i>
How many reviews do I receive?	<ul style="list-style-type: none"> • certainly the more reviews I have distributed 	<ul style="list-style-type: none"> • I don't know, possibly the more points I have received
How many points do I receive?	<ul style="list-style-type: none"> • certainly the more points I have distributed 	<ul style="list-style-type: none"> • I don't know, possibly the more reviews I have received

From Table 4 (left) it can be filtered out that “symmetric reviewers” (i.e. the pragmatic) have two potentially inciting arguments for higher levels of own activity (in reviewing and granting points) that are both coupled back to what they have lived themselves so far. Systemically speaking, this constitutes a feedback circle as it might be coupled back in a proportionate manner (i.e. positive feedback circle). “Non-symmetric reviewers” (i.e. the non-pragmatic) have no such feedback loop constituted by their pattern of motivation – but they appear to be more concentrated on the “real target”.

This means that personalities inclined to “pragmatic behavior” might either slip into a self-enhancing circle of ever more review activities or else slip into a loop where already low activity is still lowered by the mechanism of motivation thus leading to very poor overall performance in the review game of SGC level 2. Quite nicely this diagnosis fits with Figure 18 where could be seen one “green” maximum for the “good ones” (according to the trainer’s assessment on the horizontal axis) and another smaller maximum for the “weak ones”.

Similarly, from Table 4 (right) it can be filtered out that “non-symmetric reviewers” have a generally lower level of readiness to see or even accept such structural driving factors for their success. Their motivation grounds elsewhere, most likely in “the (ethically sound) quality” of their contribution.

The same structure of deliberations, only for expectations of what will happen to them is shown in Table 5. The logical

structure of the left column allows for a positive feedback circle (dynamic), the logical structure of the right column does not (static).

Table 6: Constituents for the two subsets (“symmetric” and “non-symmetric”) reviewers: where do they depend on?

	<i>symmetric reviewers</i>	<i>non-symmetric reviewers</i>
Logical structure	<ul style="list-style-type: none"> • positive feedback circle (dynamic) 	<ul style="list-style-type: none"> • no positive feedback circle (static)
Source of motivation	<ul style="list-style-type: none"> • exogenous 	<ul style="list-style-type: none"> • endogenous

Table 6 finally hints at the more dynamic structure of the “motivation engine” which could explain that “the *second-best* students” in Figure 18 are *exogenously* motivated and helped by this *feedback circle* and therefore attaining *higher grades* compared to the pure trainer’s assessment. This is one of the *great surprises* of the SGC game, at least to its author and trainer.

It could be generalized that symmetric reviewers (i.e. the pragmatic) tend to build the picture of a “*convex world*” which is oriented to *outside values* whereas non-symmetric reviewers (i.e. the non-pragmatic) tend to build a “*concave world*” which is oriented to *inside values*. It is apparent that society always constitutes a certain *blend* of personalities working along both systems of motivation. The struggle between the “inside world” and the “outside world” has left traces since long, e.g. since the prophets in the old scriptures complaining about their non-acceptance in the world.

Another conclusion is repeated from above: In general it becomes clearly visible that both functionalities of game rules – namely “optimizing the pattern of *social flow*” and “creating a *true picture* of the students’ competence” – do not necessarily always act in the same direction; very ideally both functionalities could be separated.

Additionally one very basic observation can be induced from the above findings: *it seems that very principally a system of rules or of values can never completely be communicated to another human being*. There seems to exist an intrinsic and irremovable bias between the system of values *communicated* and the system of values *perceived*. For example the trainer had in mind to communicate a system of mutual aid, spirit of collaboration and orientation towards global issues but students get caught in the dynamics of striving for *personal success* in points. Any game and any system attempting to reproduce “*real idealism*” by *outside* rules and external motivators will be too short to approximate proper human *internal* motivation.

Such findings have to be taken into account when planning and designing *communicational spaces* (Healey et al., 2008, Castells, 2010) for “*interdisciplinary and intercultural learning*” (Global Studies, 2011, USW, 2011, IE, 2011). Symbolically speaking, “views on reality” are provided by GIS (Figure 24).

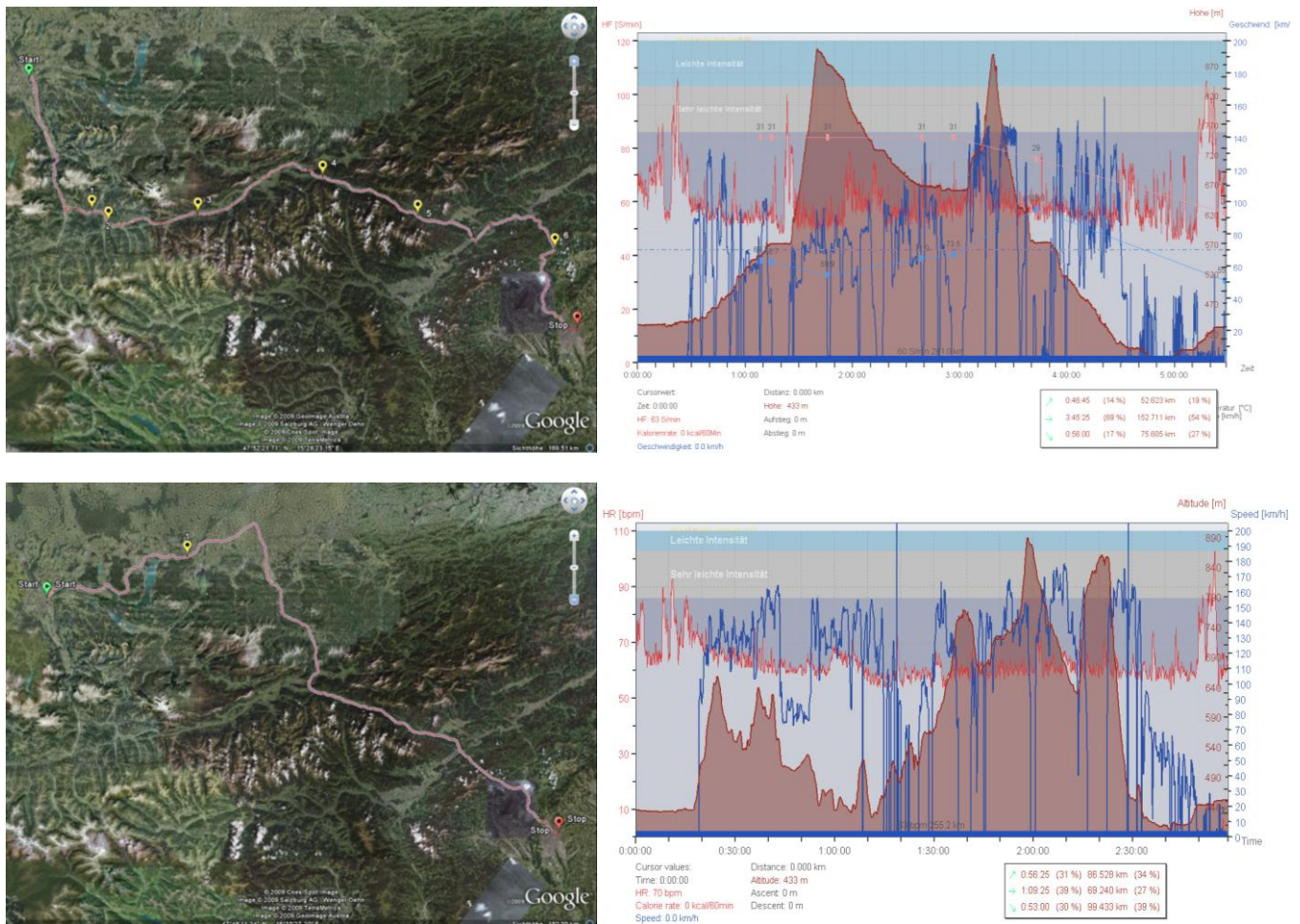

Figure 25: Views on reality as provided by (Geographic) Information Technologies: Travel by (above) train and (below) car across Austria from Salzburg to Graz seen (at left) through the (“objective”) lens of GPS data mapped by Google Earth or (at right) through the (“individual”) lens of heart rate data (red), altitude data (brown), speed data (dark blue), average speed data (light blue) and temperature (pink) shed light on how different individuals’ views on reality can be.

References

- Ahamer, G. (2004). Negotiate your future: Web based role-play. *Campus-Wide Information Systems*, 21(1), 35-58, see <http://www.emeraldinsight.com/1065-0741.htm>. (Outstanding Paper Award 2005: http://www.emeraldinsight.com/info/authors/literati_nets/awards/papers_2005.jsp#5).
- Ahamer, G. (2006). SURFING GLOBAL CHANGE: Negotiating sustainable solutions. *Simulation & Gaming - an International Journal*, 37(3), 380-397. <http://www.unice.fr/sq/>, text at <http://sag.sagepub.com>.
- Ahamer, G. (2008). Virtual Structures for mutual review promote understanding of opposed standpoints. *The Turkish Online Journal of Distance Education (TOJDE)*, 9(1), 17-43, ISSN 1302-6488, see <http://tojde.anadolu.edu.tr/>.
- Ahamer, G. (2010). A short history of web based learning including GIS. *International Journal of Computer Science & Emerging Technologies (IJCSET)*, 1(4), 101-111, <http://ijcset.excelingtech.co.uk/voll1issue4/17-voll1issue4.pdf>.
- Anderson, R. S. (1998). Why Talk About Different Ways to Grade? The Shift from Traditional Assessment to Alternative Assessment. *New Directions for Teaching and Learning*, 74, 5–16, <http://onlinelibrary.wiley.com/doi/10.1002/tl.7401/abstract>.
- Berding, J.W.A. (2000). John Dewey's participatory philosophy of education – Education, experience and curriculum. The history of education and childhood, Nijmegen University, <http://www.socsci.kun.nl/ped/whp/histeduc/misc/dewey01.html>.
- Castells, M. (2010). An Introduction into the Information Age. In: G. Bridge, S. Watson (eds.), *The Blackwell City Reader*, John Wiley and Sons, pp. 40-48, see http://books.google.com/books?id=P2aC62fqCyQC&hl=de&source=gbs_navlinks_s.
- Cybrary (2011), John Dewey, American Pragmatist. A wing of the Pragmatism Cybrary, Recent editions of Dewey's writings, <http://dewey.pragmatism.org/>.
- FHJ (2011). Curricula of construction Management and of Electronic Engineering at the University of Applied Sciences (= Fachhochschule) Joanneum in Graz and Kapfenberg, Austria. See <http://www.fh->

- joanneum.at/aw/home/Studienangebot/fachbereich_leben_bauen_umwelt/~czk/bmi/?lan=en and http://www.fh-joanneum.at/aw/home/Studienangebot/fachbereich_information_design_technologien/~boct/ace/?lan=en.
- Garfield J.B. (1994). Beyond Testing and Grading: Using Assessment To Improve Student Learning. *Journal of Statistics Education* 2(1), <http://www.amstat.org/publications/jse/v2n1/garfield.html>.
- Global Studies (2011). Masters Curriculum Global Studies, Karl-Franzens University Graz, <http://www.uni-graz.at/globalstudies/>.
- Haack, S. (2004). Pragmatism, Old and New. *Contemporary Pragmatism*, 1(1), 3-41.
- Healey P.G.T., White, G., Eshghi, A., Reeves, A.J., Light, A. (2008). Communication Spaces. *Computer Supported Cooperative Work*, 17(2-3), 169-193.
- IE (2011), Internationale Entwicklung (= International Development). Curriculum at the University of Vienna, <http://www.univie.ac.at/ie/>.
- IEW (2011), Internet Encyclopedia of Philosophy: John Dewey, <http://www.iep.utm.edu/dewey/>.
- MP (2007). Selection of finalists in the highest rewarded European prize on Media Didactics MEDIDAPRIX,

http://www.medidaprix.org/mdd_2007/dynframeset_006.html.

- USW (2011). Environmental Systems Analysis (Umweltsystemwissenschaften), Reports of Interdisciplinary Practicals, see http://www.uni-graz.at/usw1www/usw1www_magazin/usw1www_berichte.htm.
- Van Rooyen, S. (1998). Effect of open peer review on quality of reviews and on reviewers' recommendations: a randomized trial. *British Medical Journal* 318(7175), 23.

Author Biography

Gilbert Ahamer: Despite being trained as a physicist, environmentalist and economist, he focused on social procedures mediated by (geographic) information technologies. At the Austrian Academy of Sciences in his birth city of Salzburg he tries to link the concept of “communicational spaces” with useful results of interdisciplinary and intercultural learning and understanding ...



... while mostly contemplating the effects of “Surfing Global Change”.

© ExcelingTech Publication, 2011

<http://ojs.excelingtech.co.uk/index.php/IJCSET>